

ASSEMBLY DIAGRAM

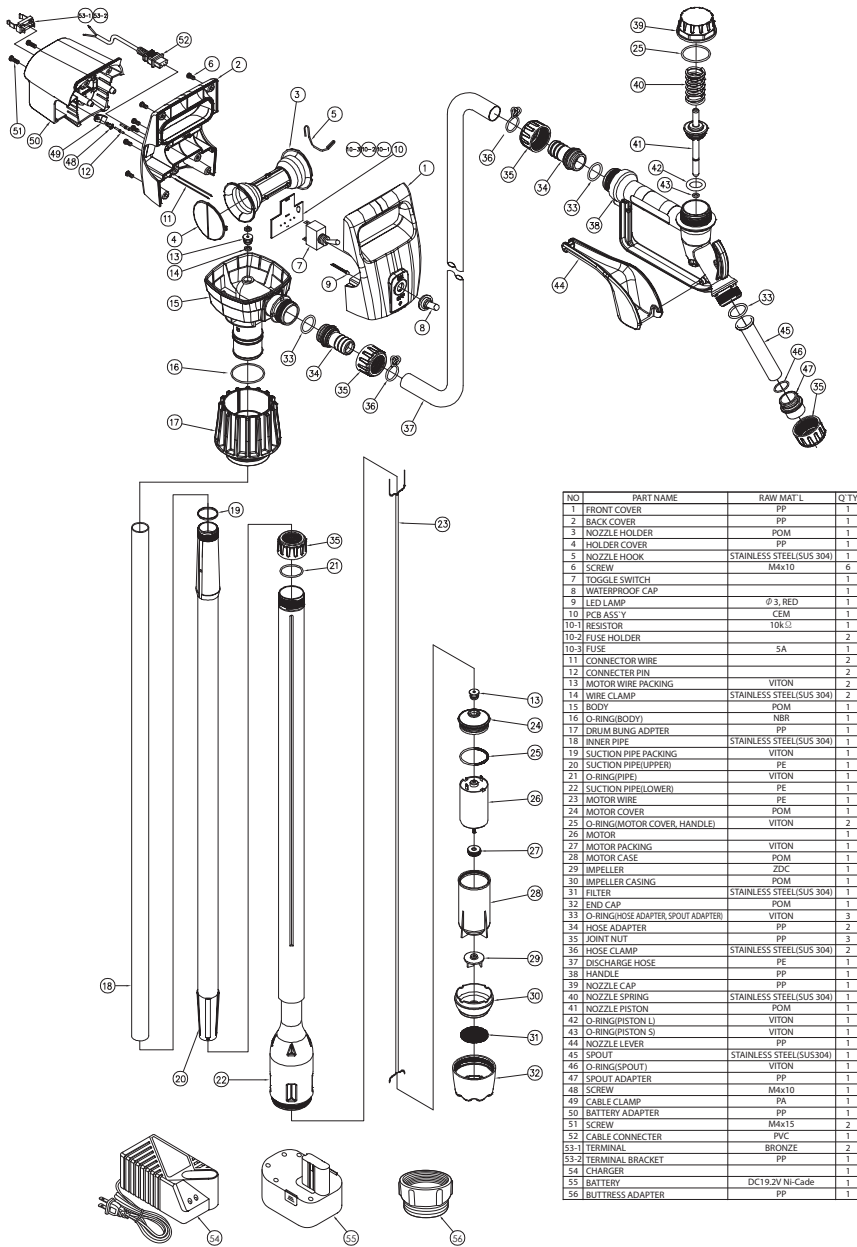

ELECTRIC DRUM PUMP

INSTRUCTIONS AND PRECAUTIONS

※ Read all instructions and precautions before use.

MODEL: TReDRUM-T

U.S. Design patent 29/501,301
Design patent EU 002530402-0001

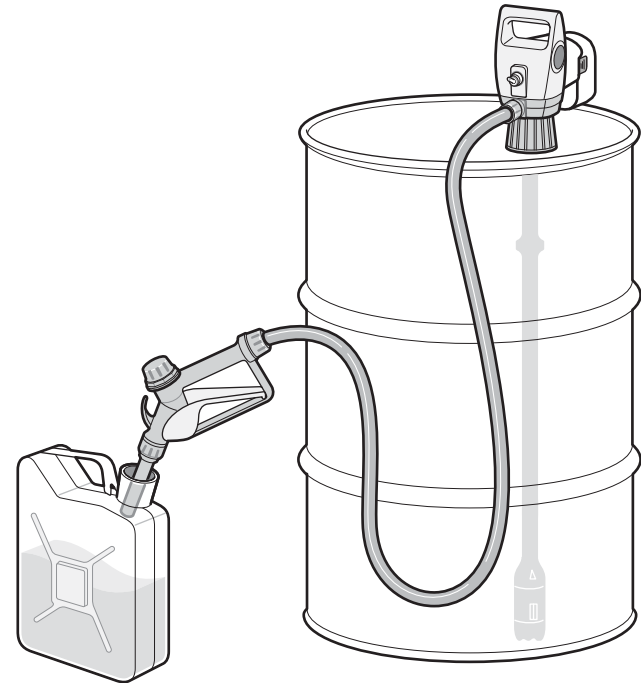

Precautions for Use

These instructions are to ensure the product is used correctly, safely, and to prevent any possible risk or damage to the user and/or others people. Our company shall not take any responsibility for any failure of product, malfunction and damages caused by improper use by the user or third parties.

DANGER

If the directions of this sign are not followed, fatal accidents can happen and the user may die or get seriously injured.

WARNING

If the directions of this sign are not followed, accidents can happen or the user can get injured.

CAUTION

If the directions of this sign are not followed, the product can get damaged or the user can get injured.

DANGER

Do not use for flammable liquids or concentrated acids.

Be cautious. This pump does not have an explosion proof motor.

Do not use near the flammable materials such as gasoline, gas, etc.

Only use on applicable liquids written on the specifications.

WARNING

Make sure the pump is tightly secured to the drum(tank) before turning the pump on.

Do not refuel directly while the vehicle or equipment is turned on.

Do not leave the pump unattended.

Make sure to use the pump on even surface.

Do not allow children to operate the product without adult supervision.

CAUTION

After using the pump, do not keep it on its side or upside down.

Make sure to remove any left-over liquid in the discharge hose after each use.

Do not alter or disassemble the ump.

Do not run the pump 'dry' or let the pump idle without transferring.

Make sure to turn off the power after using the pump.

Do not shock the pump.

Do not use deteriorated or contaminated liquids and fuels.

Do not place the pump in a wet area.

Do not use this pump for hot liquids above 40°C (104°F).

The included 19.2V Ni-Cade battery charged with about 80% from the factory and need to discharge completely each time before recharging to get it's full capability. Recharging before the battery completely discharged will shorten its charge and cannot be returned to its original storage capacity.

Names of Parts

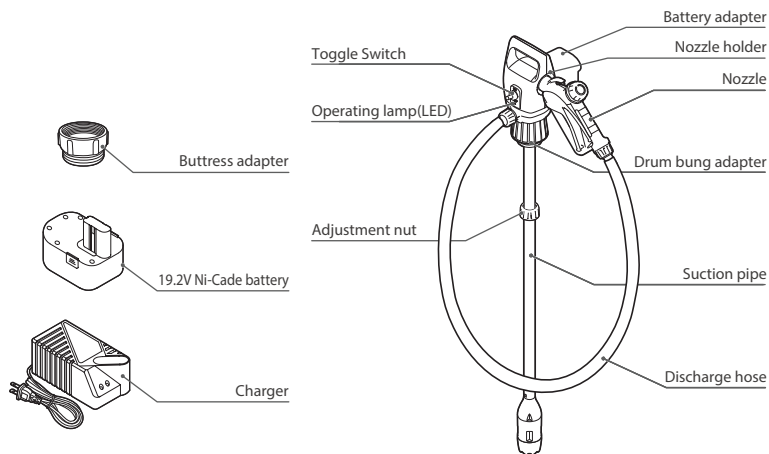

Specifications (MODEL: TReDRUM-T)

Delivery volume	Approx. 28liters (7 Gallons) at Water	Operating temperature	+5°C ~ 40°C (41°F ~ 104°F)
Suction pipe length	Approx. 850 ~ 1245mm (33.5"~ 49")	Operating voltage	DC19.2V
Discharge hose length	Approx. 2m (6.6ft)	Fuse	5A
Applicable liquids	Diesel, DEF(AdBlue), Water, Kerosene, Antifreeze, Windshield washer fluid, Mild detergents, Agricultural chemicals, Light oils.		

Directions for Use

