

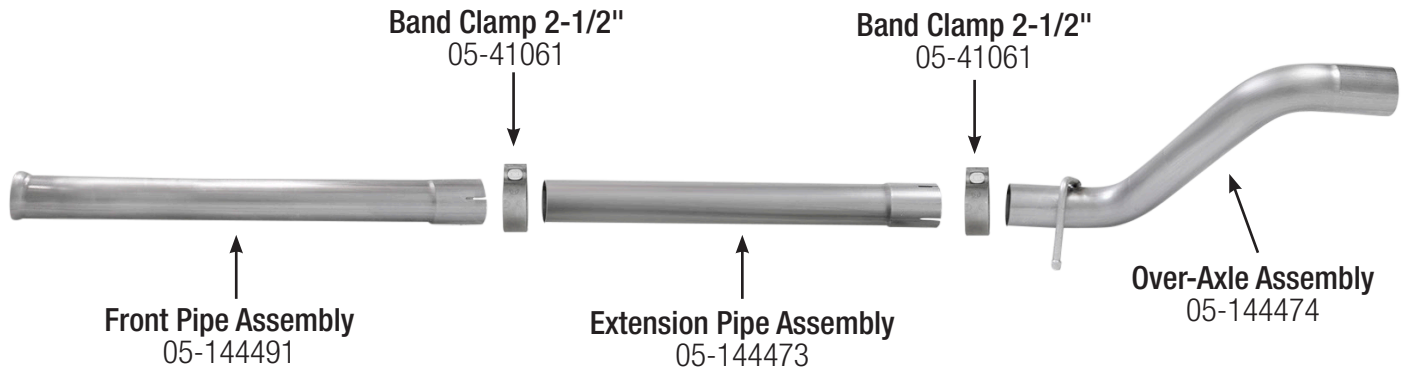

## INSTALLATION INSTRUCTIONS

**MAKE:** Jeep  
**MODEL:** Wrangler (JL)  
**YEAR:** 2018 - 2019  
**ENGINE:** V6-3.6L  
**FITS:** 2 and 4-door

**Front Resonator Delete  
Exhaust System**  
49-48077



**Caution:** aFe recommends professional installation on our products. Allow time for your vehicle to cool down prior to installation. When working on or under your vehicle proceed with caution. Exhaust systems reach high temperatures and may cause serious burns. Wear protective safety equipment; eye goggles and gloves to ensure a safe installation.

- Step 1:** **(Read Instructions prior to installation).** It may be helpful to lubricate all the factory isolation rubber mounts, before taking off stock exhaust and also before installing aFe exhaust. Always use a jack or stand for support when installing or uninstalling any exhaust system.
- Step 2:** Begin by removing your stock exhaust from the rear of your truck working your way forward. Remove the factory muffler assembly and mid-pipe/resonator. Take caution not to damage the factory isolation mounts as they will be reused.  
**NOTE:** It may be easier to unbolt the muffler hanger brackets from the frame than to disconnect the factory isolation mounts.
- Step 3:** Remove the factory ball clamp from the mid-pipe/resonator.
- Step 4:** For faster installation spread the pieces of the exhaust alongside of your vehicle, according to the diagram shown. It is recommended to not fully tighten any of the clamps until the entire system has been fully installed.
- Step 5:** Place the factory ball clamp removed in **step 3** onto the Front-pipe.
- Step 6:** Install the Front-pipe on to the factory y-pipe and loosely tighten the factory ball clamp,
- Step 7:** Place a 2-1/2" band clamp over the rear side of Front-pipe and slide the extension pipe into Front-pipe for the 4 door application. If installing for 2 door application the extension pipe is not needed.
- Step 8:** Place a 2-1/2" band clamp on the mid-pipe and slide onto the extension pipe or the front pipe depending on the vehicle application.  
**NOTE:** If the factory muffler hanger brackets were removed from the frame at **step 2** then reinstall the hanger brackets and isolators before **step 8**.
- Step 9:** Re-install the Factory Muffler.
- Step 10:** Straighten all exhaust components and begin to tighten down all clamps beginning at the front and ending at the rear.
- Step 11:** Congratulations your exhaust is now complete.  
**It is recommended to re-tighten all clamps after 50-100 miles.**