



## Installation Instructions

For Part Numbers:

- 200-996 Modular Intake Tube
- 200-796 Jr. Kit 850-135 Airaid Oiled Media Filter
- 201-796 Jr. Kit 851-135 SynthaMax Dry Media Filter - Red

- 2007-13 Cadillac Escalade
- 2007-14 Cadillac Escalade ESV/EXT
- 2007-13 Chevrolet Avalanche/Silverado 1500
- 2007-14 Chevrolet Tahoe/Suburban 1500
- 2007-13 GMC Sierra 1500/Yukon/Yukon XL 1500

4.8L V8, 5.3L V8, 6.0L V8\*, 6.2L V8  
 \*Does not fit non HD 6.0L motors after 2010

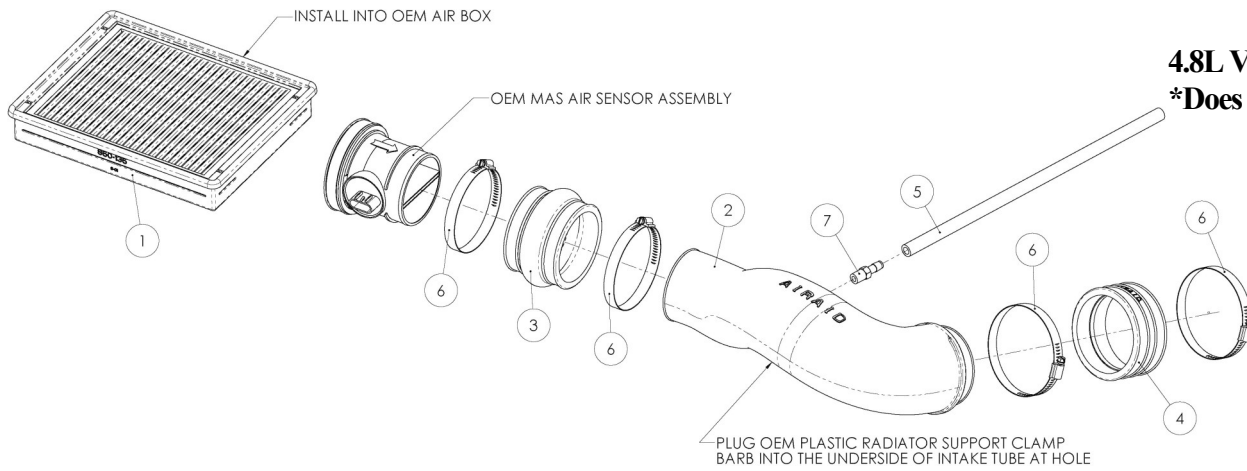

### Component Identification

1.	*Airaid Premium Filter	1
2.	Modular Intake Tube	1
3.	Urethane Hump Hose	1
4.	Urethane Coupler	1
5.	3/8" x 14" Breather Hose	1
6.	#64 Hose Clamp	4
7.	1/4" NPT x 3/8" Barb Fit.	1

\* Filter included only in Jr. Kits

Full color instructions can be viewed on our web site at [Airaid.com](http://Airaid.com).



**1. Disconnect the negative battery cable.**  
 Remove the factory beauty cover by lifting up on the front, and then pulling the cover towards the front of the vehicle. It is only held in place by grommets.



**2.** Disconnect the factory breather hose at the valve cover.



**3.** Separate the factory intake tube from the plastic clamp barb that secures the radiator hose to the tube. A firm downward push will usually do it.



**4.** Loosen two hose clamps on the factory intake tube. One at the throttle body end, and the other at the Mass Air Flow sensor (MAF) end.



**5.** Slide the factory intake tube off of the MAF sensor, rotate it up so that it disengages from the mounting grommet on the intake manifold, and then slide it forward off of the throttle body and remove it from the vehicle.



**6.** Install the urethane coupler (#4) on the throttle body end of the Modular Intake Tube (#2) with two #64 hose clamps (#6). Install the urethane hump hose (#3) on the other end of the MIT with the remaining two #64 hose clamps. Leave all clamps loose for now. Install the 3/8" barbed fitting (#7) into the MIT, and slide the 3/8" breather hose (#5) over the barbed fitting as shown.





7. If you purchased the 200-996 kit, proceed to step # 9. If you purchased a Jr. Kit, remove 4 screws in the factory airbox with a #25 Torx bit, and remove the factory air filter. Proceed to step #8.



8. Install the Airaid Premium filter (#1) into the factory airbox, and re-install the 4 screws.

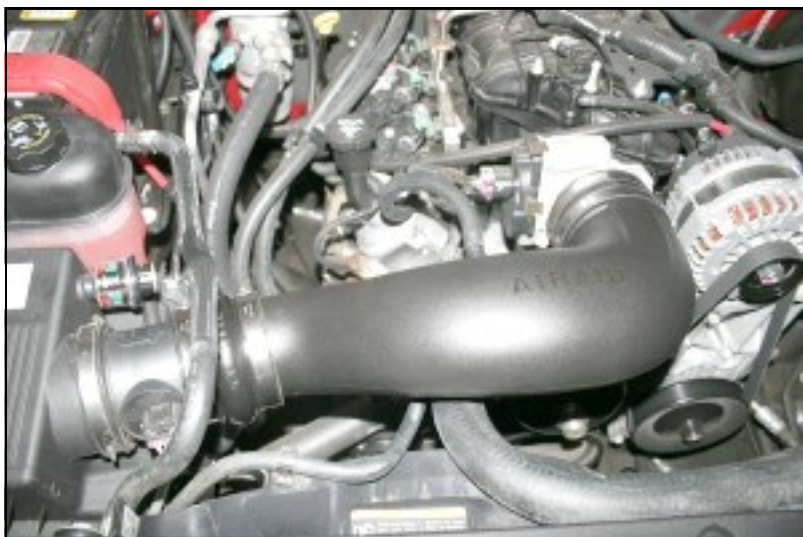

9. Install the MIT onto the MAF first, and then onto the throttle body. Adjust for fit, and tighten the hose clamps. Next connect the breather hose to the factory breather port on the valve cover. Reinstall the factory hose clamp barb back into the hole in the bottom of the MIT. Reinstall the beauty cover.

### 10. Double check your work!

Make sure there is no foreign material in the intake path. Make sure all clamps, hoses, bolts, and screws are tight.

### 11. Re-connect the negative battery cable!

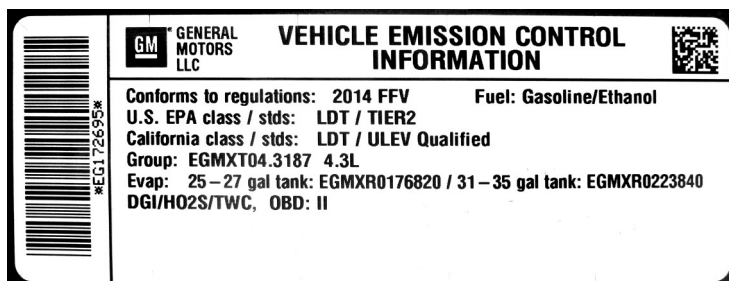

**WARNING!** If your vehicle has a Vehicle Emission Control Information decal affixed to the factory airbox, a new replacement label must be obtained and installed in a readily visible position in the engine compartment in order to remain CARB compliant. Failure to do so will prevent the vehicle from passing a smog check. Replacement labels can be ordered from your local dealership. Regulations state that the VECI label shall not be affixed to any equipment which is easily detached from the vehicle. Label placement, under the hood on a painted surface is recommended.

Thank you for purchasing the Airaid Intake System. Contact Airaid @ (800) 498-6951 8:00 AM - 5:00 PM MST weekdays for questions regarding fit or instructions that are not clear to you. Your Airaid Intake System was carefully inspected and packaged. Check that no parts are missing, or were damaged during shipping. If any parts are missing, contact Airaid. The air filter element is protected from direct exposure to water and debris; care should be taken not to drive through deep water. WATER INGESTION IS THE DRIVERS RESPONSIBILITY! The air filter is reusable and should be cleaned periodically.

### FILTER IDENTIFICATION

850-135 Airaid Oiled Media

851-135 Airaid SynthaMax Dry Media

For your Oiled media filter we suggest using the AIRAID Filter Tune-Up Kit!



P/N 790-551 Aerosol Spray  
P/N 790-550 Squeeze Spray



*SynthaMax*

**Do Not Oil**

Synthamax Air Filters do not require oil. Service air filter as needed by cleaning with common non-petroleum all-purpose household cleaner and water. Simple Green®, Formula 409® or equivalent works great. Apply cleaner to outside of air filter and allow to soak. Then flush filter clean from the inside out with a garden hose and repeat steps if necessary. Do not apply high pressure water or air to clean filter. Allow filter to air dry and reinstall.