

INSTALLATION GUIDE

AMP RESEARCH Power Step

MADE IN USA

APPLICATION	LENGTH	MODEL YR	PART #
Ford Expedition	83"	2020	76336-01A

INSTALLATION TIME

2-3 Hours

Professional installation recommended

SKILL LEVEL



4= Experienced

TOOLS REQUIRED

- Safety goggles
- 10 mm socket
- 13 mm socket
- 13 mm end wrench
- Ratchet wrench and extension
- Wire stripper
- 9/32" & 19/64" Drill Bit
- 3/16" hex key wrench (allen wrench)
- 4mm hex key wrench (allen wrench)
- Electrical tape
- Weather proof caulking (silicone sealer)

WARRANTY

5-Year Limited Warranty

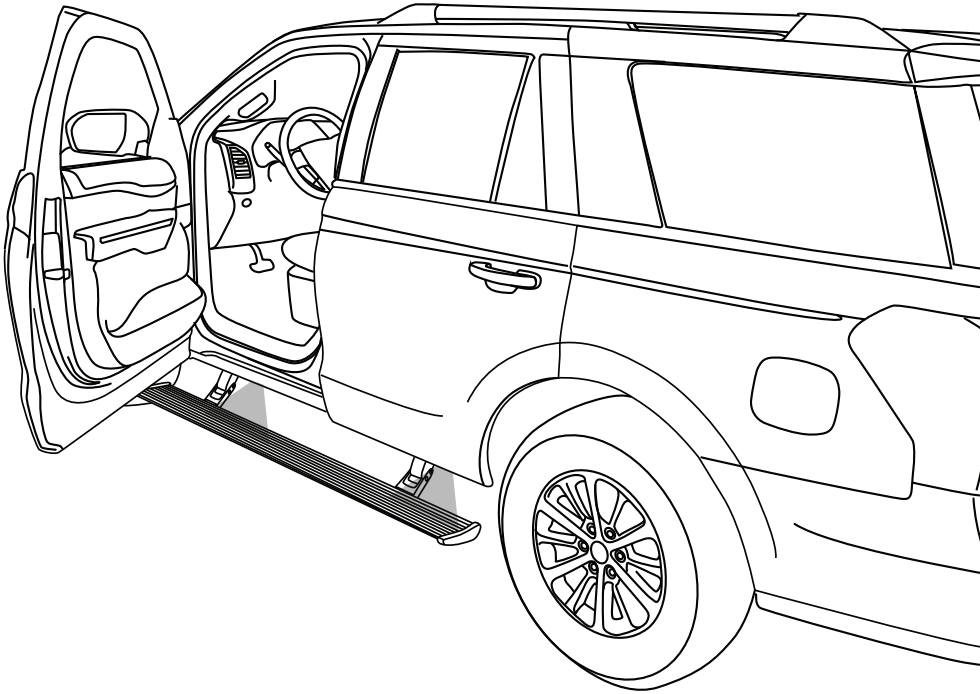

AMP RESEARCH TECH SUPPORT 1-888-983-2204 (Press 2) Monday - Friday, 7:00 AM - 5:00 PM PST

Invented, engineered and manufactured exclusively by AMP Research in the USA. May be covered by one of the following patents: 6,641,158; 6,830,257; 6,834,875; 6,938,909; 7,055,839; 7,380,807; 7,398,985; 7,584,975 ©2012 AMP Research. All rights reserved. Printed in USA.

INSTALLATION GUIDE

Attaching motor to linkage assembly

The motors must be attached to the linkage assemblies after linkage installation, after Step 2.

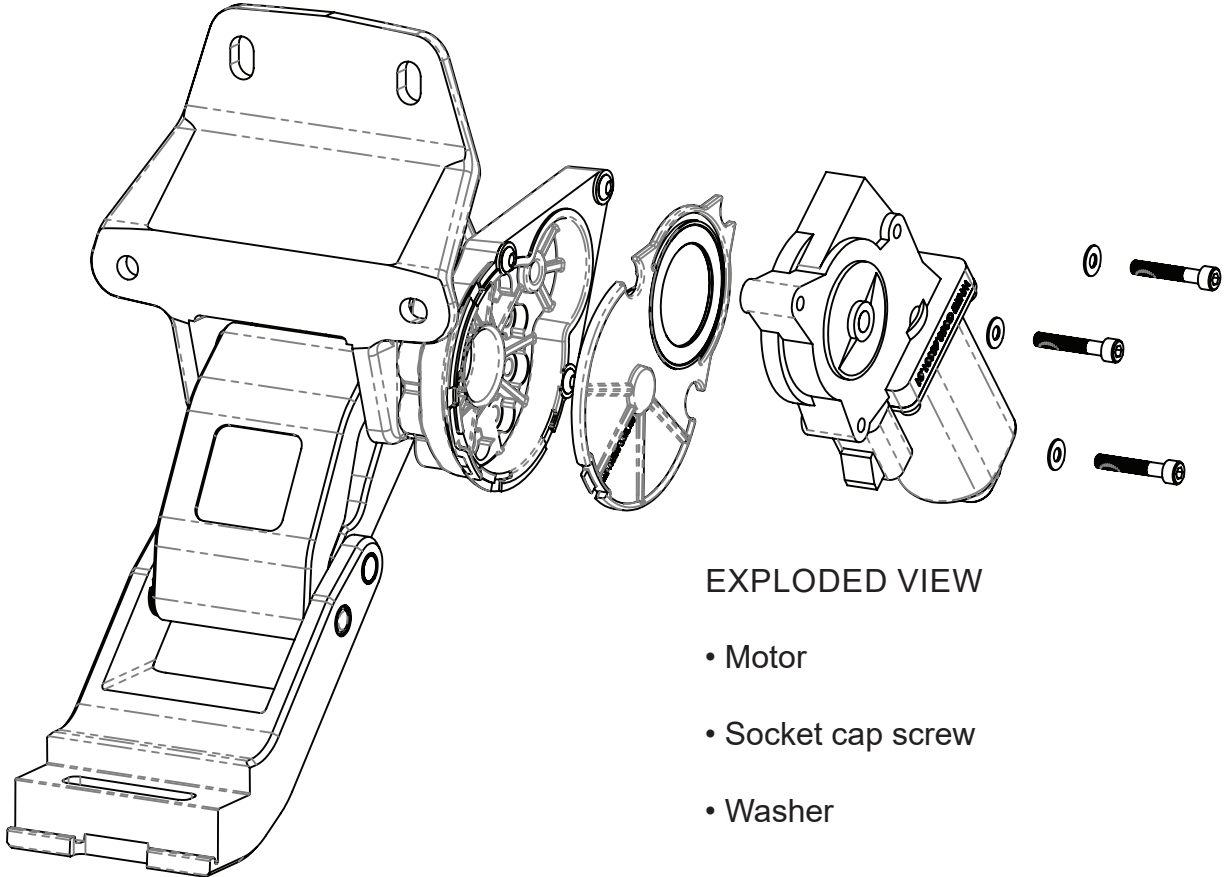

EXPLODED VIEW

- Motor
- Socket cap screw
- Washer

CAUTION: HANDLE WITH CARE.

To insure our customers receive all components with full integrity, we pack the motors separate from their linkage assemblies. This requires that the installer position and fasten the motor before continuing with the install. Please follow the instructions below and handle the assembly carefully.

CAUTION: Dropping the assembly or any excessive impact MAY cause damage to the motor.

Instructions:

1. Position the gear cover in place as shown if not already in place.
2. Seat motor into position on the three mounting bosses. This may require an adjustment of the gear by moving the swing arms.
3. After seating into place, fasten the motor with the three motor mount screws with 4mm allen wrench. Tighten screws to 36 in-lbs (4N-m). Do not over torque.

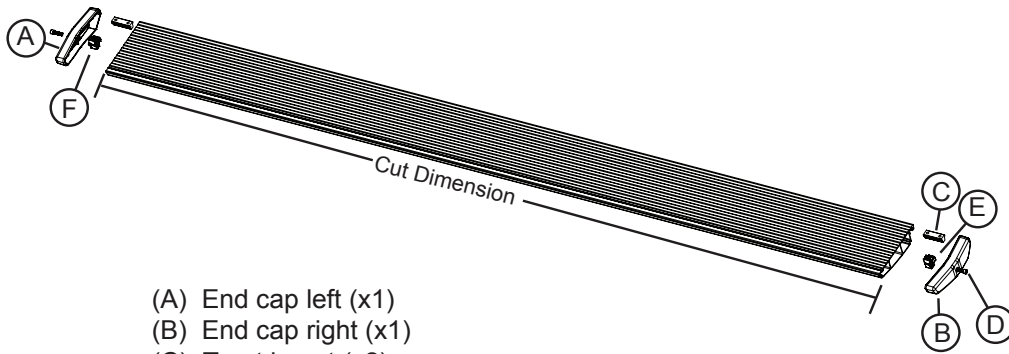

- (A) End cap left (x1)
- (B) End cap right (x1)
- (C) T-nut insert (x2)
- (D) Socket cap screw (x2)
- (E) End cap wedge right (x1)
- (F) End cap wedge left (x1)

1 x2

Running board assembly

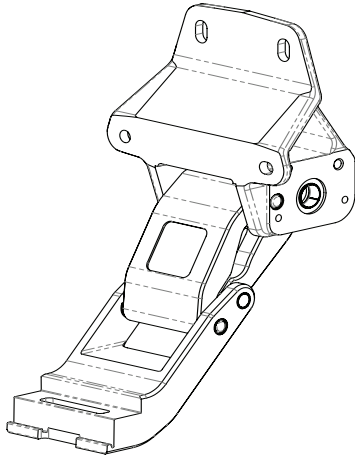

2 x2

Idler linkage assembly

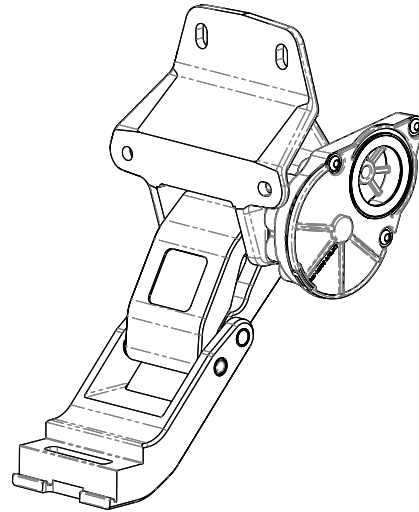

3 x2

Motor linkage assembly

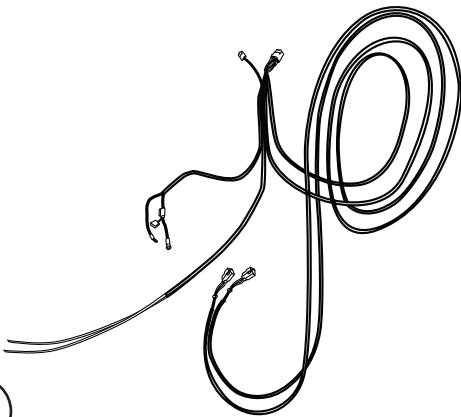

4

Wire harness

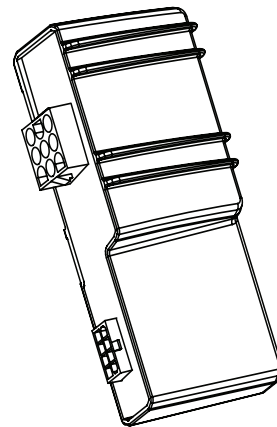

5

Controller STA

PARTS LIST AND
HARDWARE
IDENTIFICATION



6 x2
Posi-Lock™ (Grey)

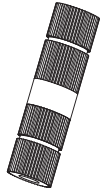

7 x2
Posi-Tap™ (Pink)

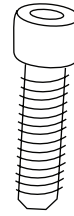

8 x8
Socket cap screw

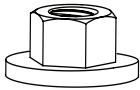

9 x12
Nut with Conical Washer

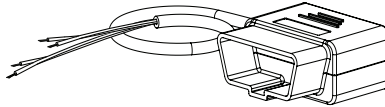

10
ODB II

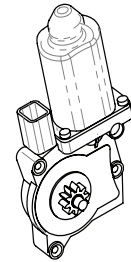

11 x2
Motor

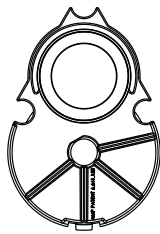

12 x2
Gear Cover

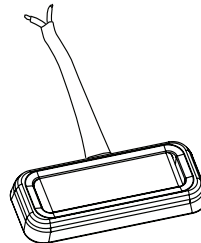

13 x4
LED Light



14 x4
Grommet

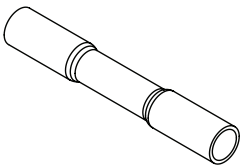

15 x8
Butt Connector

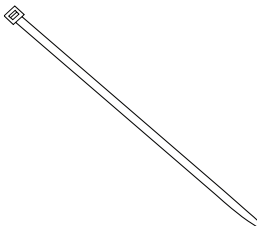

16 x20
Cable Ties 7"

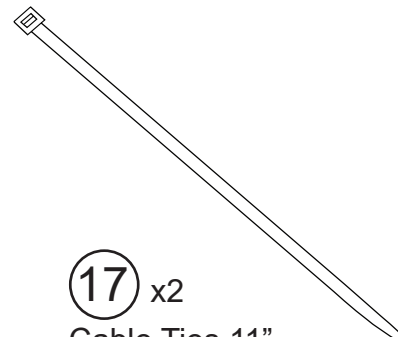

17 x2
Cable Ties 11"

Locate mounting points; first and last set of studs on the inner sill. Motor Linkage mounts toward the front of the truck and Idler mount toward the rear. Driver side shown below.

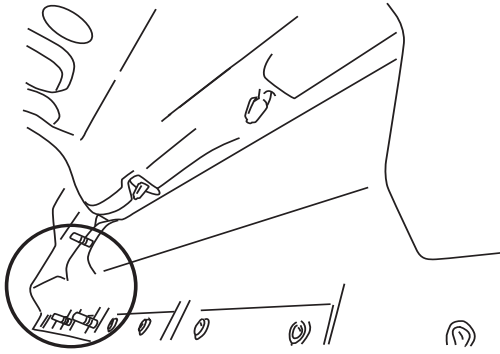

Driver Side Rear Stud Location

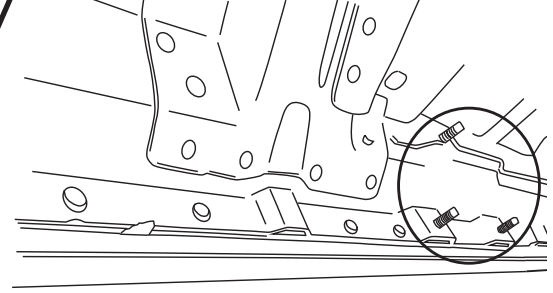

Driver Side Front Stud Location

1

Mount front drive linkage assembly. **Install the nut(12), on the motor side of the linkage, as the linkage goes on, due to little install clearance.** An open end wrench is needed at shallow angles, down and at the opposite angle upward.

Repeat for passenger side. Make sure linkages sit square, fully resting on studs before tightening. Torque to 16 ft. lbs (22Nm).

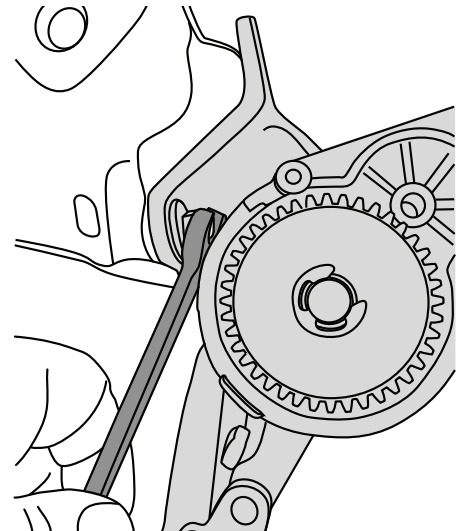

Drive Linkage (Front)

2

Mount rear Idler linkage assembly with three nuts(12). Repeat for passenger side. Make sure linkages sit square, fully resting on studs before tightening. Torque to 16 ft. lbs (22Nm).

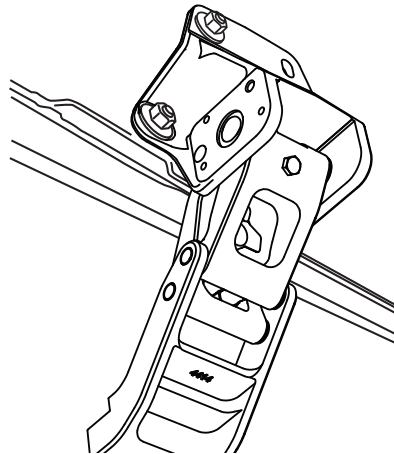

Idler Linkage (Rear)

3

Remove fuse from wire harness

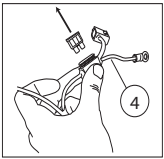

Attach wire harness to controller (make sure connector locking tabs fully engage). Mount controller with the two 11" tie wraps to factory conduit, just forward of battery.

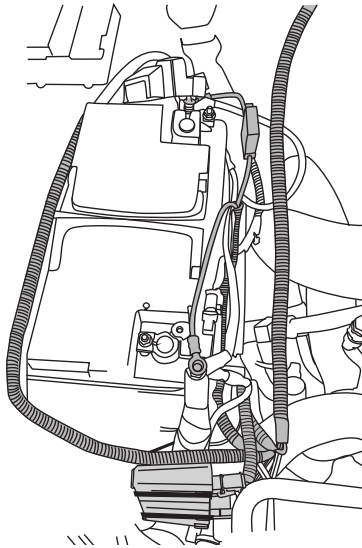

4

Connect red and black power leads to battery accessory studs. Red lead goes to positive. Route shorter leg of harness down passenger side wheel well and longer leg of harness down along driver side wheel well. Secure with tie wraps.

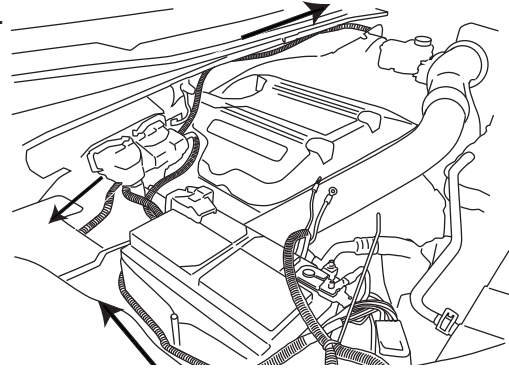

5

Route factory harness underneath vehicle and plug in motors (both sides). Route remaining LED light wires back towards rear of vehicle.

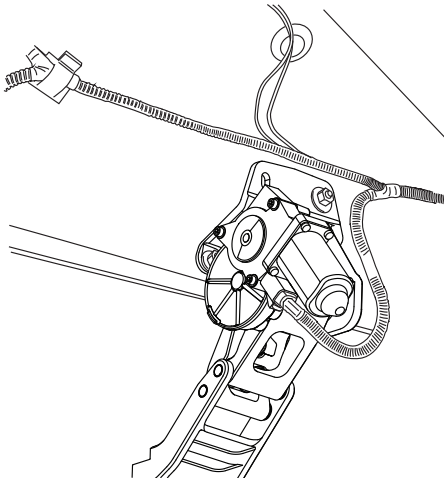

6

Remove driver side front kick panel and door sill plate. Roll back carpet to access hole for passing trigger wires into cab of vehicle.

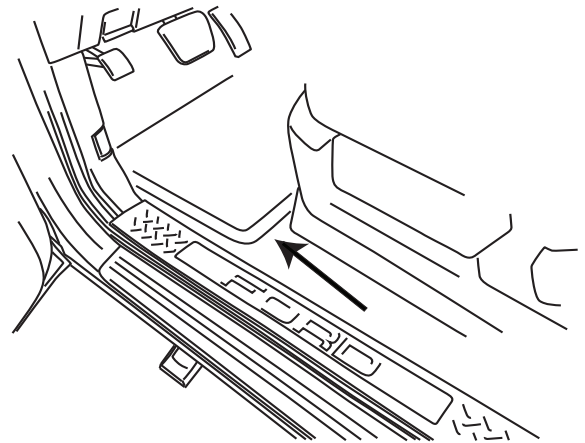

7

Remove grommet in floor panel above front linkage on driver side. Poke small hole into grommet and thread the two trigger wires through and up into the cabin of vehicle. Seal grommet with silicone sealer.

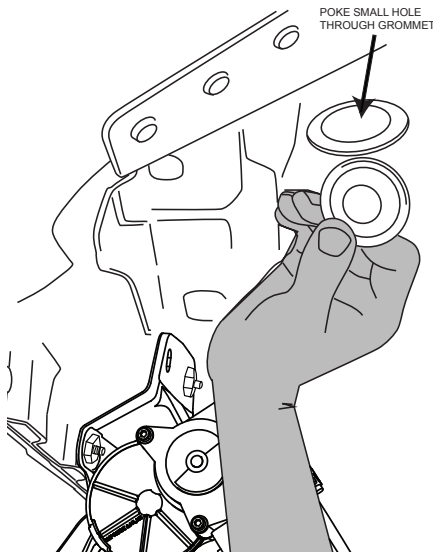

8

Locate OBD port and remove bolt and nut holding it in place with 8mm socket to gain better access to back side of plug.

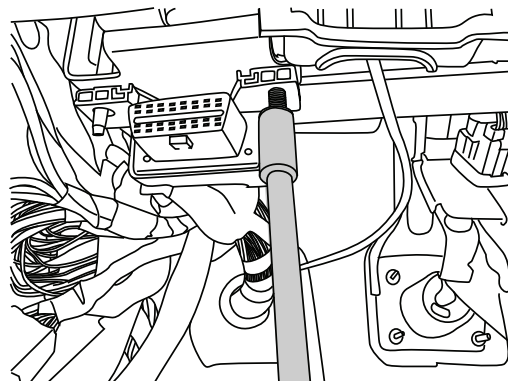

9

Locate the following wires and connect with supplied Posi-Tap™ to the following wire colors listed below.

Factory Can Wire	OBD Module wire Color
Grey with Orange Stripe	White Wire
Purple with Orange Stripe	Blue Wire

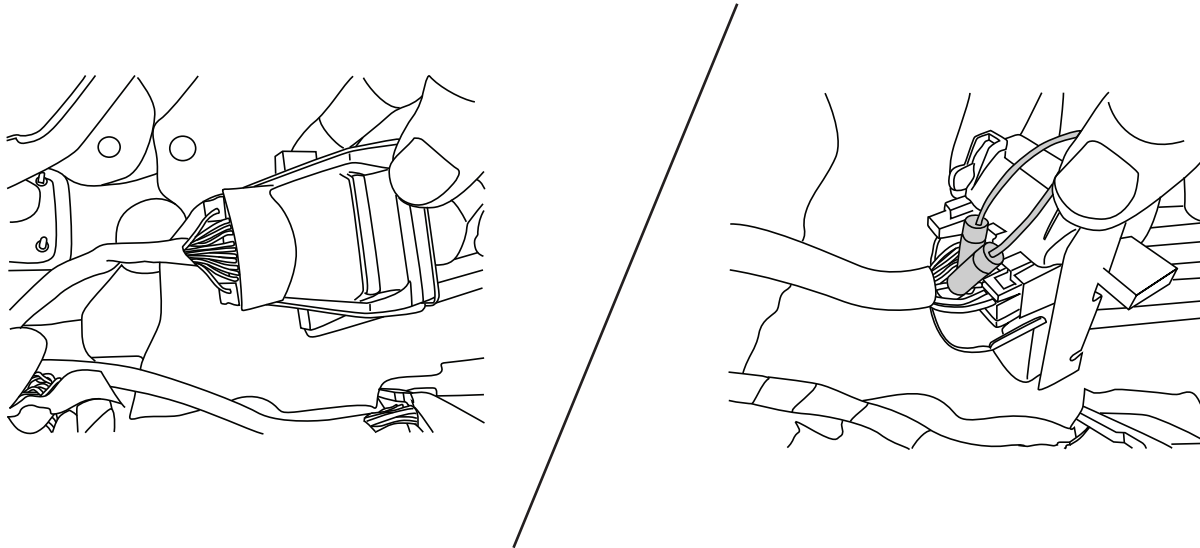

10

Use supplied Posi-Lock™ connectors to attach the 2 purple wires of the obd harness to the main harness. Attach matching colors on the harness to the wires on the module. Lastly reinstall Factory OBD port removed in step 11. Plug in module to OBD port on the vehicle.

Reinstall sill plate removed from step 8.

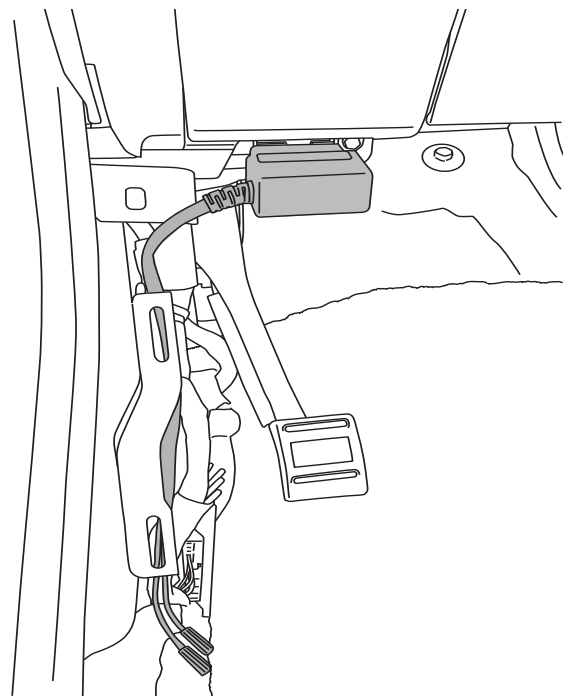

11

OBD II install: Use Supplied Posi Twist connectors to attach the Plug and Play Module to the Harness. Attach matching colors on the harness to the wires on the module. Plug in module to OBD II port on the vehicle. Secure harness with supplied tie wraps.

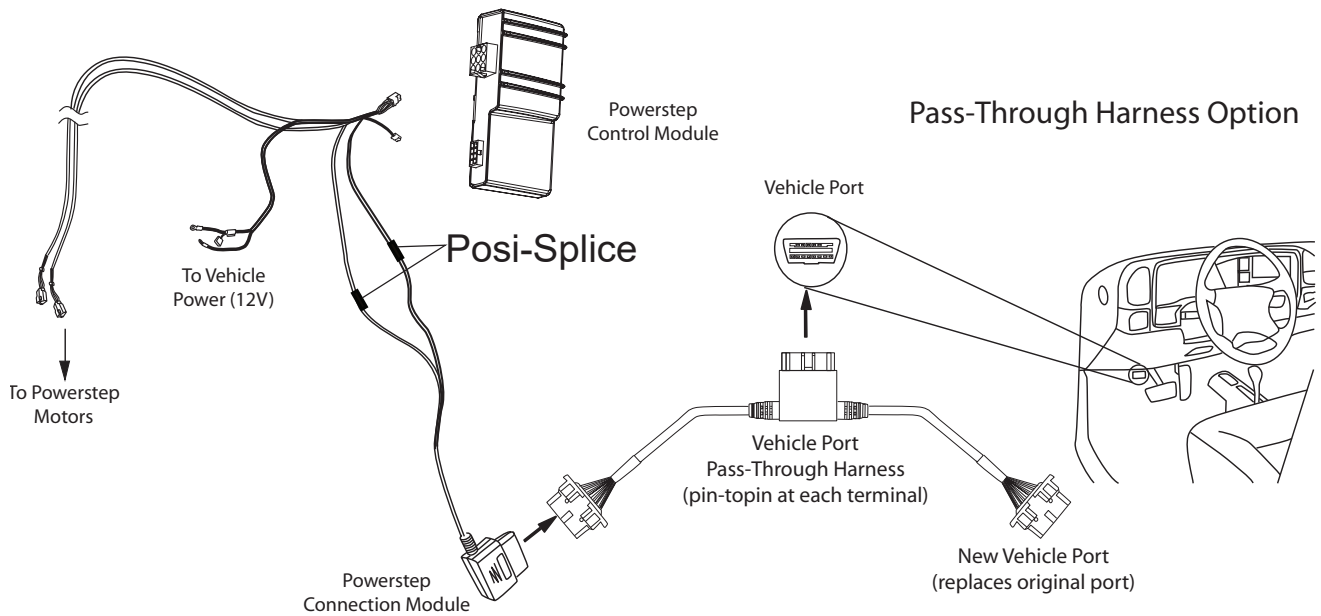
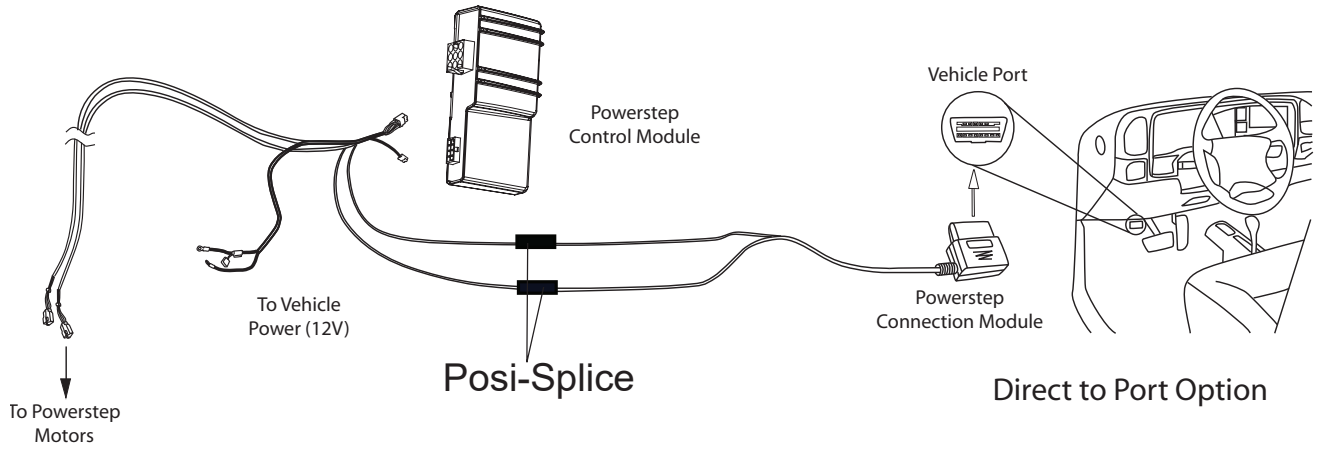

Attach step, sliding the mounting T-nut into position. Torque to 10 ft lbs (13.5 Nm)

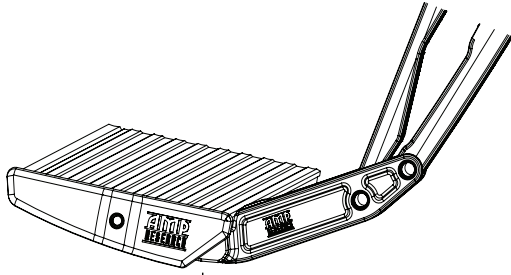

13

The boards should be centered on the rocker on each side of the vehicle.

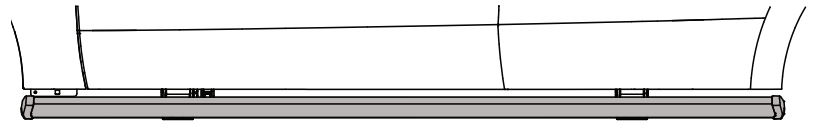

Drive Side Shown
Front of Vehicle



14

On each side of the vehicle use tape to mark the led drill location as shown below the front is a factory hole that doesn't need to be drilled. Use tape to indicate. Front location is approximately 22" from front door edge and rear is 2-3" behind linkage, where spot weld isn't.

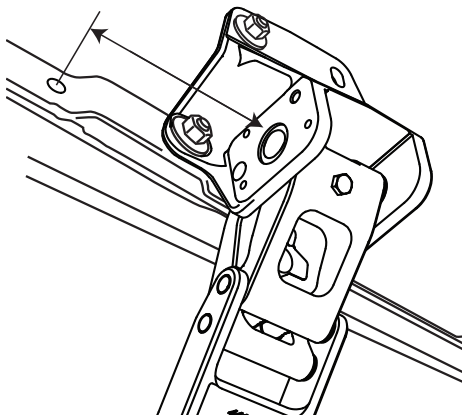

15 Drive Side Rear Mounted

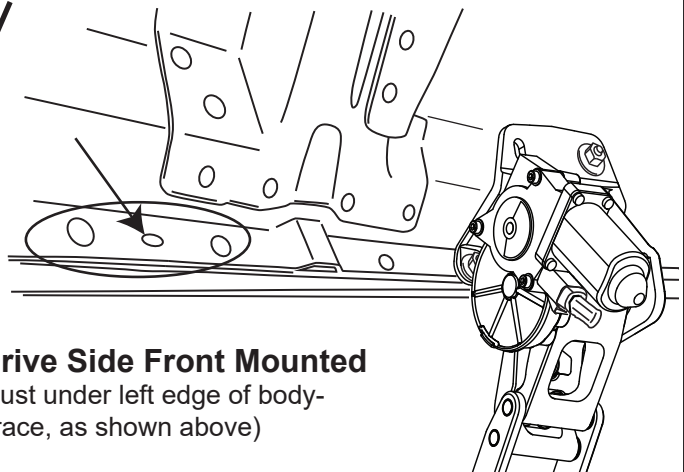

Drive Side Front Mounted

(Just under left edge of body-brace, as shown above)

15

Mark hole location 1/2" to the midpoint of the rocker with tape and center punch and drill 19/64" hole into pinch weld. Deburr hole and insert grommet (13) for LED Wire.

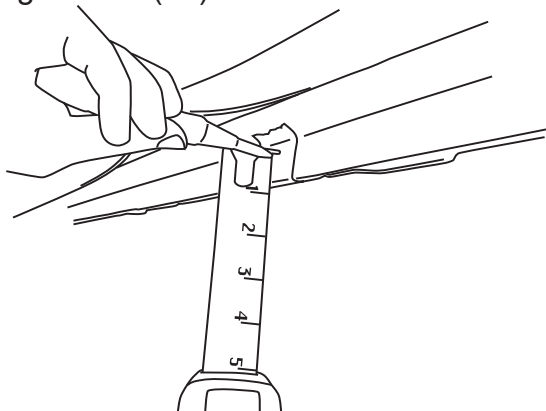

16

Route LED wires though through grommet, clean surface, and stick on to rocker panel as shown below.

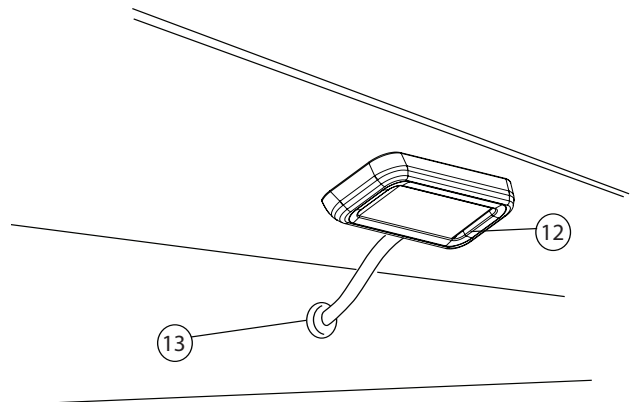

17

Using supplied butt connectors, connect the lamp wires. Red to Red, Black to Black. Heat the shrink tubing on the connectors to seal wires.

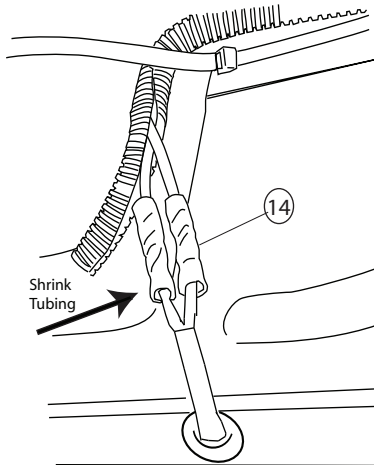

Close and wrap with conduit and electrical tape. Secure all loose wires with cable ties with lamp wires pulled upward to avoid any wire snagging.

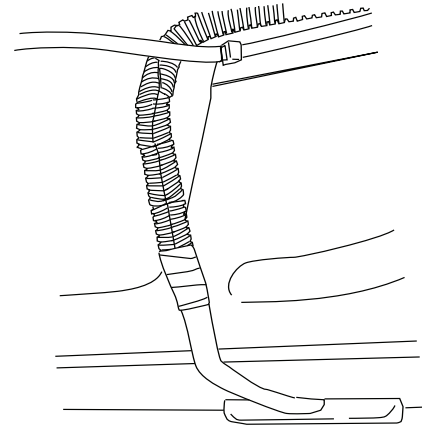

18

19

Replace fuse.

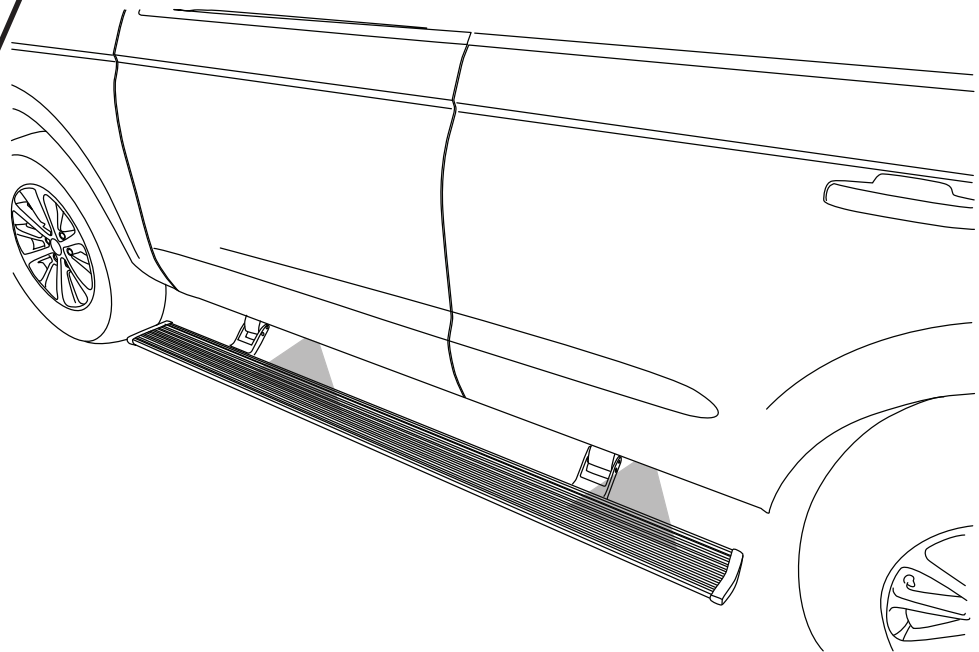
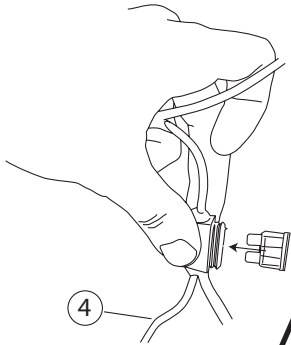

FINAL SYSTEM CHECK

Check that all doors activate the PowerStep and the LED lights work when doors open and close.

NORMAL OPERATION: When the doors open, PowerStep automatically deploys from under the vehicle. When the doors are closed, PowerStep will automatically return to the stowed/retracted position. **Note that there is a 2-second delay before the PowerStep returns to the stowed/retracted position.**

CORRECT OPERATION OF LIGHTS: All four lamps will illuminate upon opening any door of vehicle. Lamps will stay on until restowing of both Power Steps or until 5 minutes has expired with the doors open. When the lights timeout after 5 minutes, they can be reilluminated by closing and opening any door of vehicle.



PowerStep™

Congratulations on your purchase of the genuine AMP Research PowerStep! Here's what you should know...

POWER-DEPLOYABLE RUNNING BOARDS OPERATION: AMP Research PowerStep running boards automatically move when the doors are opened to assist entering and exiting the vehicle.



Automatic power deploy:

The running boards will extend down and out when the doors are opened.

Automatic power stow:

The running boards will return to the stowed position when the doors are closed. There will be a 2-second delay before the running boards move to the stowed position.

Automatic stop:

If an object is in the way of the moving running board, the running board will automatically stop. To reset, clear any obstruction, then simply open and close the door to resume normal operation.



Manually set in the deployed (OUT) position for access to the roof:

The running boards can be manually set in the deployed position by firmly holding the step down with your foot while at the same time closing the door. To resume normal operation, open and close the door.

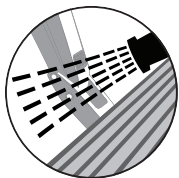

Maintenance: In adverse conditions, debris such as mud, dirt, and salt may become trapped in the running board mechanism, possibly leading to unwanted noise. If this occurs, manually set the running boards to the deployed position and flush the front and rear hinge arms with a high-pressure car wash wand. Avoid spraying the motors directly. After washing, apply silicone spray lubricant to the hinge pivot pins. Do not apply silicone, wax or protectants like Armor All® to the running board stepping surface.

Caution! Keep hands away when the running board is in motion.

5-YEAR LIMITED WARRANTY

AMP RESEARCH warrants this product to be free from defects in material and workmanship for FIVE (5) YEARS FROM DATE OF PURCHASE, provided there has been normal use and proper maintenance. This warranty applies to the original purchaser only. All remedies under this warranty are limited to the repair replacement of the product itself, or the repair or replacement of any component part thereof, found by the factory to be defective within the time period specified. The decision to repair or replace is wholly within the discretion of the manufacturer.

This warranty specifically excludes labor. If you have a warranty claim, first you must call our factory at the number below for instructions. You must retain proof of purchase and submit a copy with any items returned for warranty work. Upon completion of warranty work, if any, we will return the repaired or replaced item or items to you freight prepaid. Damage to our products caused by accidents, fire, vandalism, negligence, misinstallation, misuse, Acts of God, or by defective parts not manufactured by us, is not covered under this warranty.

ANY IMPLIED WARRANTIES OF MERCHANTABILITY AND/OR FITNESS FOR A PARTICULAR PURPOSE CREATED HEREBY ARE LIMITED IN DURATION TO THE SAME DURATION AND SCOPE AS THE EXPRESS WRITTEN WARRANTY. OUR COMPANY SHALL NOT BE LIABLE FOR ANY INCIDENTAL OR CONSEQUENTIAL DAMAGE.

Some states do not allow limitations on how long an implied warranty lasts, or the exclusion or limitation of incidental or consequential damages, so the above limitations or exclusions may not apply to you. This warranty gives you specific legal rights, and you may also have other rights that vary from state to state.

FOR WARRANTY ISSUES WITH THIS PRODUCT PLEASE CALL AMP RESEARCH CUSTOMER SERVICE 1-888-983-2204

WARNING

Be sure to read and precisely follow the provided instructions when installing this product. Failure to do so could place the vehicle occupants in a potentially dangerous situation. After installing or reinstalling, re-check to insure that the product is properly installed.