



**Edelbrock 2011-13 Chevrolet Camaro
Convertible Brace
Part #15956**



Edelbrock 2011 - 13 Chevrolet Camaro Convertible Brace

Installation Instructions

INTRODUCTION

This Edelbrock convertible brace is designed to be used on 2011 and Later Chevrolet Camaro convertibles equipped with an Edelbrock Supercharger. The OEM convertible brace interferes with the installation our the Edelbrock heat exchanger, so we have designed a new brace that allows clearance, yet retains O.E. functionality.

TOOLS REQUIRED

- Jack and Jack Stands
OR Service Lift
- Panel Puller
- Ratchet and Socket Set
- Wrenches
- Flat Blade & Phillips Screwdrivers
- Compressed Air
- Torx-20 Driver
- Torque Wrench
- Impact Wrench

Edelbrock LLC, 2700 California Street, Torrance, CA 90503
Toll-Free Tech Line: 1-800-416-8628 Office/Sales Line: 310-781-2222



Edelbrock 2011 - 13 Chevrolet Camaro Convertible Brace

Installation Instructions

If you are in the process of installing your Edelbrock Supercharger, please use this instruction sheet to supplement the one received with the supercharger kit.

Installation of the convertible brace begins after the OEM brace has been removed and the Edelbrock heat exchanger has been installed. Refer to steps: 11-13 of this instruction sheet, after which you may continue on with the installation of the supercharger.

If you previously completed the installation of the Edelbrock Supercharger, then install the convertible brace as follows:

1. Open the trunk and lift the trunk liner to access the plastic hold down. Unscrew the plastic hold down, then remove the air compressor and foam support.
2. Remove the negative battery terminal.
3. Remove the positive battery terminal by lifting the protective cover then loosen the nut.

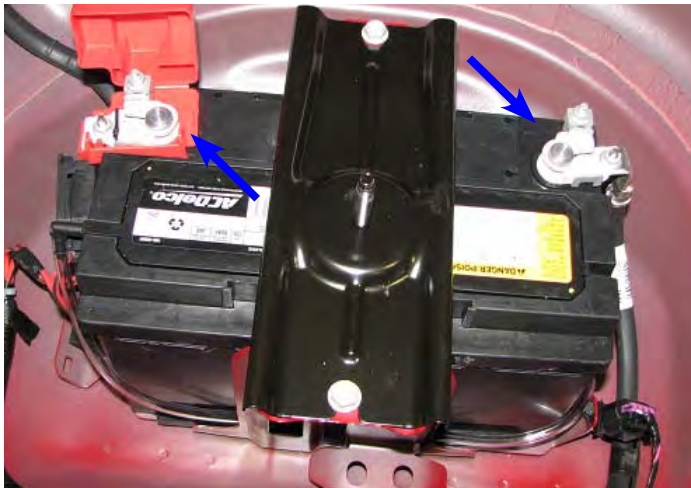

4. Lift and support the front end of the vehicle using a service lift, or jack and appropriately load rated jack stands. Loosen and remove the lug nuts from both front wheels, remove the front wheels and set them aside.

5. Remove the fender liners using a T20 Torx wrench, unscrew the five bolts and a panel puller to remove the five body pins. Then set the fender liners aside.

- (1) Five bolt locations
- (2) Five body pin locations

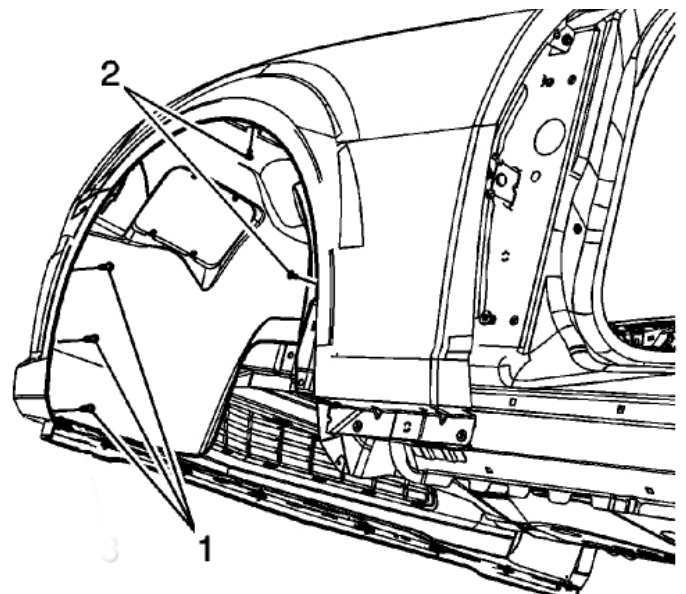
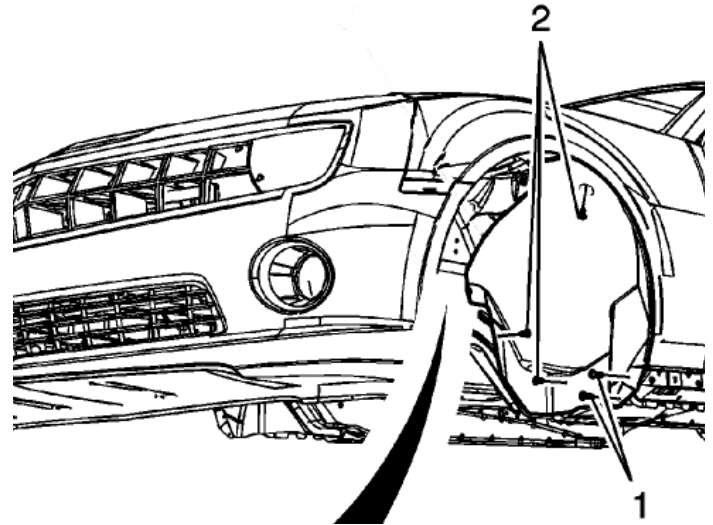



Edelbrock 2011 - 13 Chevrolet Camaro Convertible Brace

Installation Instructions

6. Begin removing the front fascia by reaching in through the wheel wells with a 10mm socket to remove the four bolts at the front of each side of the fascia then use a 7mm socket to remove the two bolts on each side of the front fascia.

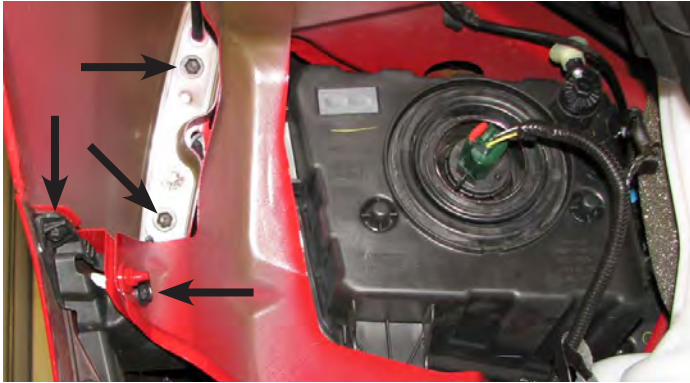

7. Disconnect wiring harnesses on the passenger side; they consist of: the fog lamp electrical connectors and the fascia wiring harness.

8. Remove the two bolts retaining the bottom of the fascia using a 10mm socket.



9. Remove the six body pins that are secured to the top of the fascia with a panel puller, then remove the bolt at each end with a 10mm socket.



10. Remove the front fascia by pulling it forward and off the vehicle, then set it aside.

If you are currently installing your Edelbrock Supercharger, ensure that the original brace has been removed and the heat exchanger is installed, then continue on with the following steps.



Edelbrock 2011 - 13 Chevrolet Camaro Convertible Brace

Installation Instructions

11. Remove the air deflectors attached to the right and left of the radiator. Each deflector is secured by two plastic push pins and a molded extrusion that is pressed into the radiator core. Once the rivets have been removed, firmly pull the deflector in towards the radiator so as to remove the molded extrusion. Finally pull the deflector up and out of the vehicle.

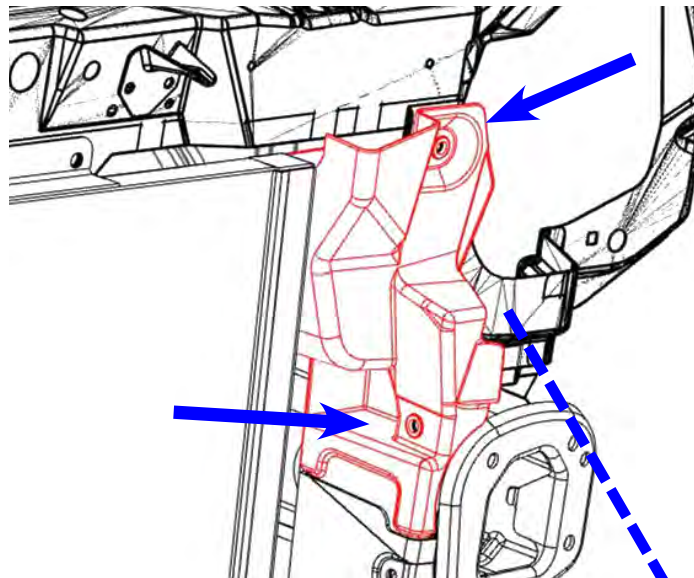

Rivet location: Driver Side defelctor

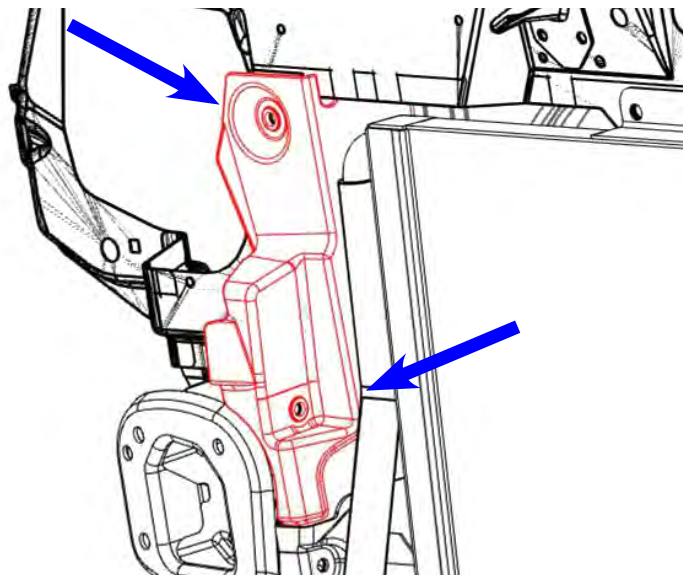

Rivet Location: Passenger Side deflector

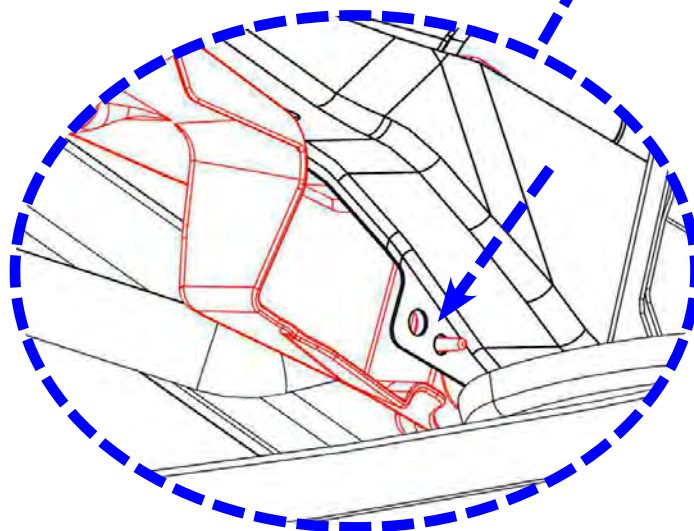

Molded extrusion on back side of each deflector



Edelbrock 2011 - 13 Chevrolet Camaro Convertible Brace

Installation Instructions

12. Cut a relief into each deflector, so as to make room for the new brace to pass through. Use a pair of shears to cut along the dotted line as depicted below.

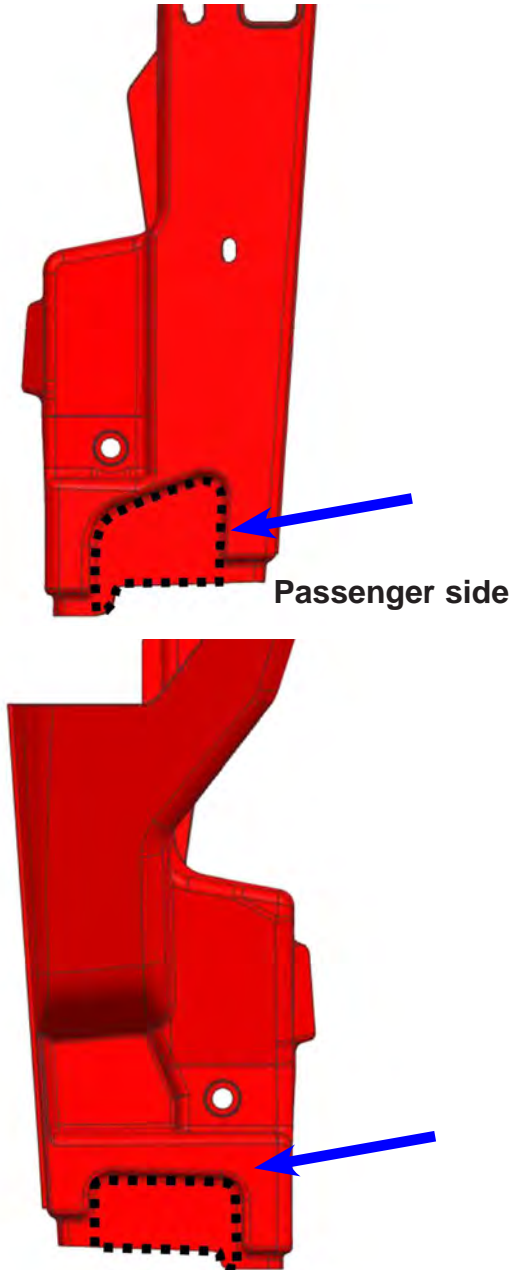

13. Remove the bolts from the top heat exchanger bracket. Install the brace, aligning it with the threaded holes in the frame (2 holes) and radiator support (2 holes). Then utilize the provided hardware to mount the brace.

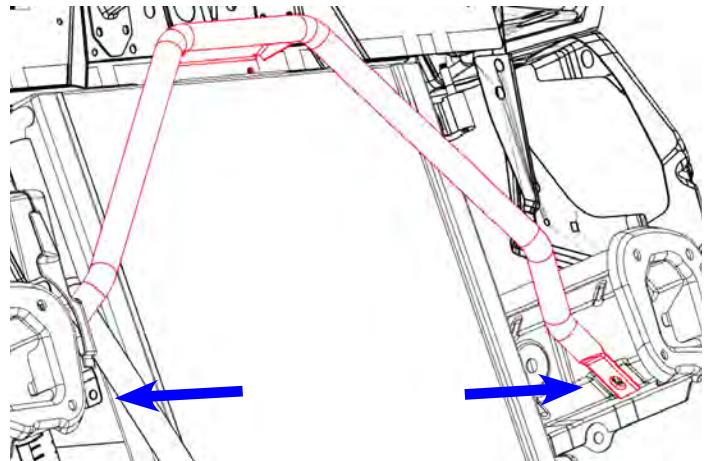
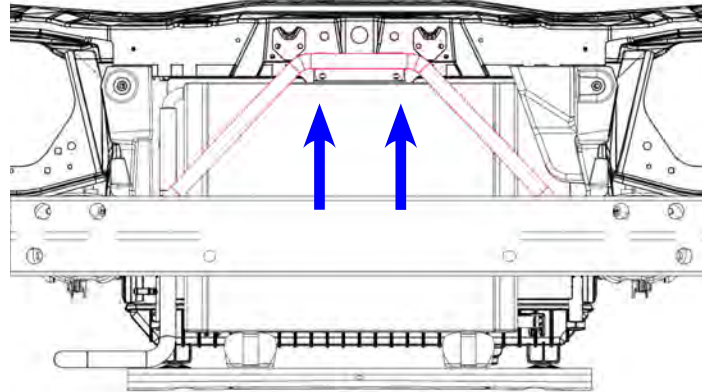

If you are in the process of installing your Edelbrock Supercharger, disregard the following steps and continue on with supercharger instructions sheet.

14. Re-install the: air deflectors, front fascia, harnesses, fender liner, and wheels
15. Lower the vehicle
16. Re-connect battery.