

Set # 5-4101 & # 5-4102



1131 VIA CALLEJON, SAN CLEMENTE, CA 92673

Removal

It is recommended that a factory service manual be purchased prior to performing any work on your car or truck.

Note: When disassembling, note the quantity and positions of any shims that may have been inserted for body alignment. These shims will have to be reused to insure proper body alignment.

Remember: Only raise body high enough to remove & replace mounts. Always watch the fan shroud for sufficient clearance when raising the body. When jacking the body use a long enough 2X4 or 4X4 for maximum support. Never put jack directly on body panels.

Install mounts one side at a time with bolts on other side loosened only.

Retorque to factory specs.

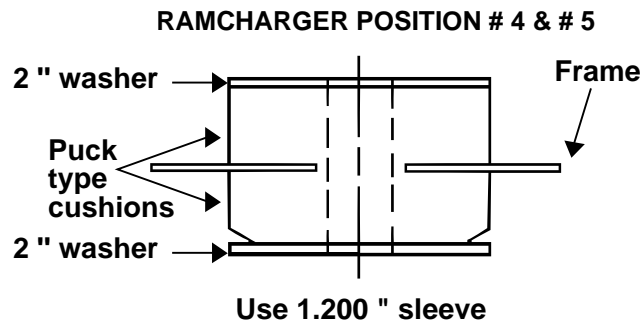
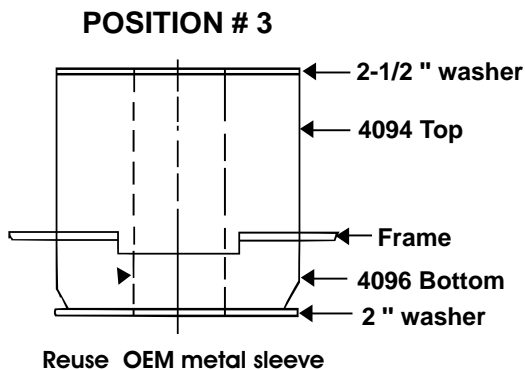
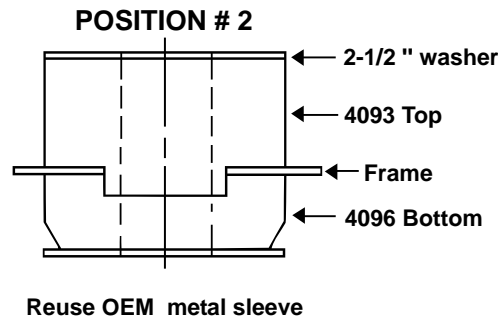
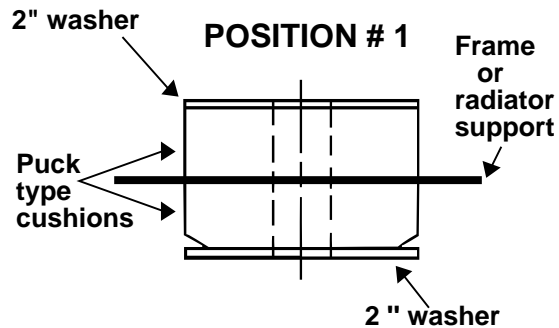
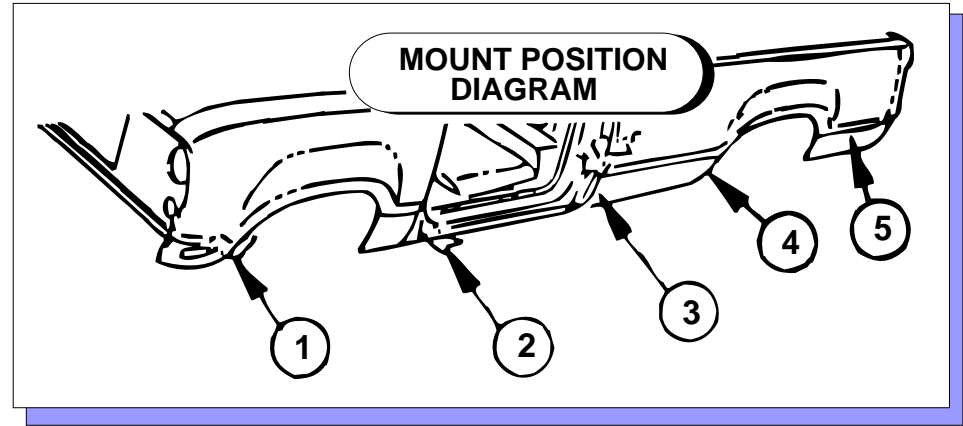

Typical style 1978-1985 P/U and all Ramchargers

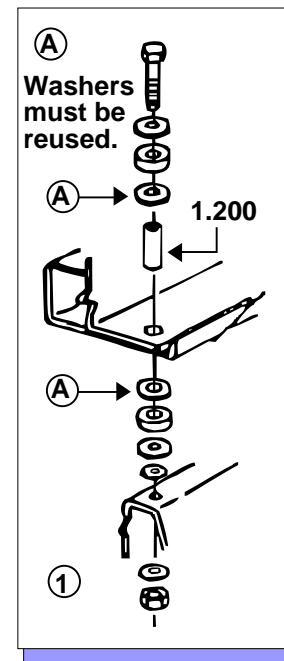

1st Style

Typical style 1972-1977 P/U and 1978-1981 Diesel P/U only

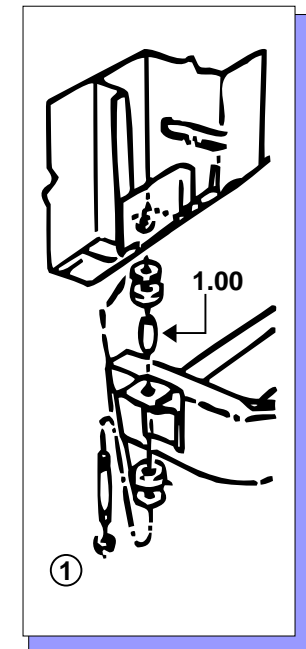

2nd Style

Note: On mount position # 3 when shoulder bolt installs from bottom up. Original 2" washers must be reused at the bottom. Also 2-1/2" washer with 1/2" I.D. will now be used at the top. (2-1/2" washer with 3/4" I.D. is not used)

17070

Updated 4/JAN/02 BRH

© 2002 Energy Suspension. All rights reserved. May not be reproduced, in any form, or by any means, without the written consent of Energy Suspension.