

# INSTRUCTION SHEET FOR SET #3.4160

## Body Mount Bushing Set



1131 VIA CALLEJON, SAN CLEMENTE, CA

It is recommended that if you are unfamiliar with this type of work that you refer to a qualified service center specializing in this type of work. It is also recommended that if you choose to do this work yourself that a factory service manual be obtained for the proper procedures pertaining to removal, replacement and proper torque specifications for your vehicle. This instruction set is intended as a guideline for the safe installation of Energy Suspension's Polyurethane.

© 2006 Energy Suspension. All rights reserved.  
May not be reproduced, in any form, or by any means, without the written consent of Energy Suspension.

NOTE: When disassembling the body mounts, be sure to note the number and position of shims that may have been used to align the body. These shims will have to be reused to retain proper body alignment.

NOTE: The factory bracket used at position #5 to hold the lower cushion in place must not be reused. Supplied nuts are for rear bumper bolts.

CAUTION: Remove all the body mount bolts on one side of the vehicle. Loosen but do not remove all the body mount bolts on the opposite side of the vehicle. Only raise one side of the vehicle at a time, lifting the body only high enough to remove/replace the mounts. Always watch the fan shroud, brake lines, and various hoses for sufficient clearance when raising the body. When jacking the body use a 2x4 or 4x4 or equivalent to spread the weight. Never place jack faces directly on body panels!

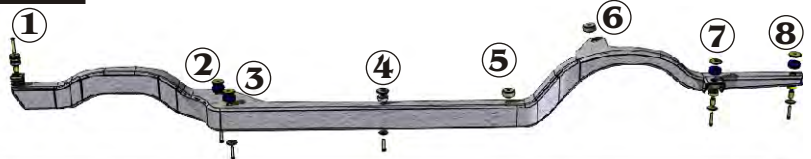

### BILL OF MATERIALS

- 4 - 4021 Bushing - Position 1 upper
- 10 - 4025 Bushing - Position 2,3,4,7,8 upper
- 2 - 4057 Bushing - Position 1 lower
- 10 - 4028 Bushing - Position 2,3,4,7,8 lower
- 4 - 4111 Bushing - Position 5,6 upper
- 12 - 15.03.09.39 Washer (2"x.437"x.120")
- 8 - 15.03.14.39 Washer (2.5"x.500"x.125")
- 2 - 15.03.28.39 Washer (2.5"x.750"x.120")
- 2 - 15.03.36.39 Washer (1.75"x.500"x.125")

### BILL OF MATERIALS

- 4 - 15.03.104.39 Washer (2.5"x1.75"x.125")
- 2 - 15.05.08.39 Bolt (7/16"-14 x 3")
- 8 - 15.05.54.39 Bolt (7/16"-14 x 2.5")
- 2 - 15.05.76.39 Bolt (7/16"-14 x 2.25")
- 2 - 15.07.02.40 Nut (7/16"-14 Nylock)
- 6 - 15.10.59.39 Sleeve (.875"x.750"x1.5")
- 6 - 15.10.91.39 Sleeve (.875"x.750"x1.375")
- 1 - 17480 Instruction Sheet

### POS ①

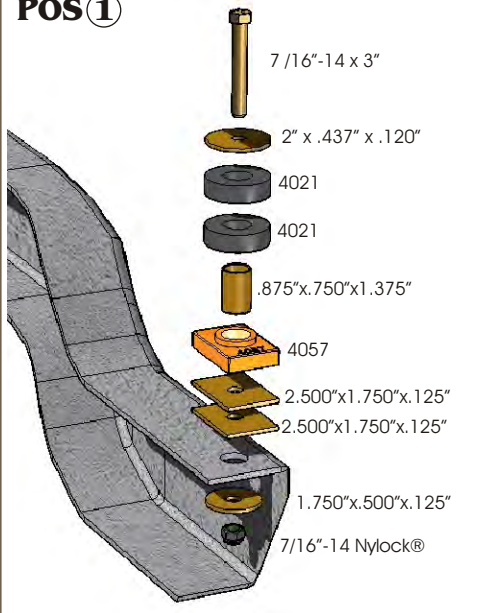

### POS ②,③

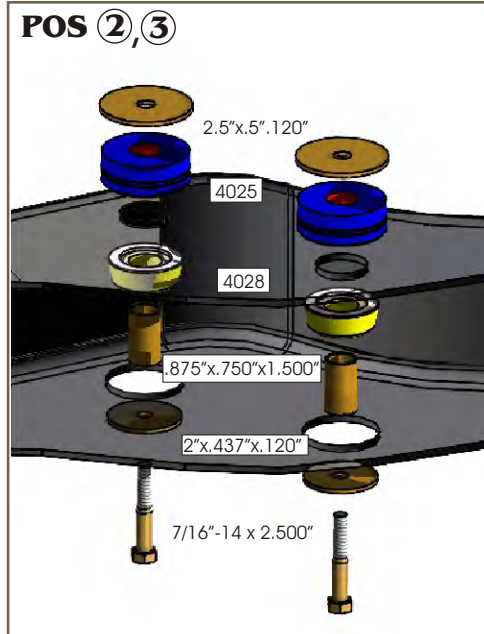

### POS ④

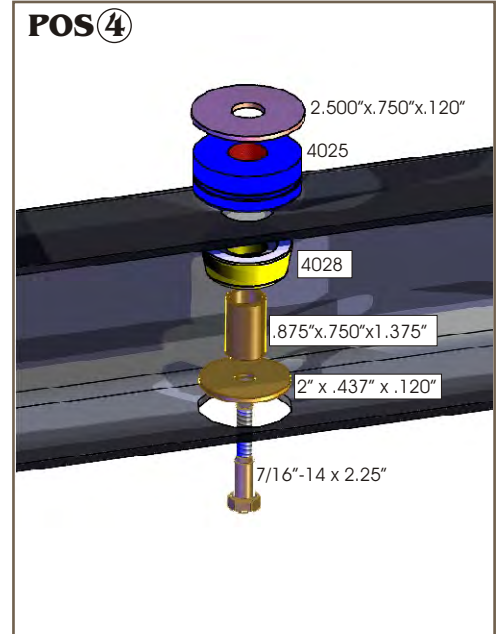

### POS ⑤,⑥

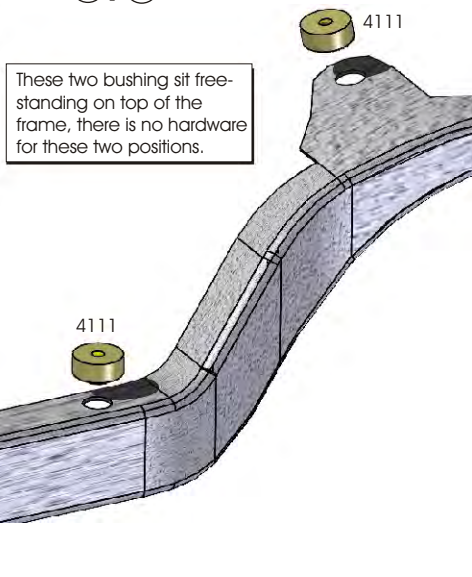

### POS ⑦

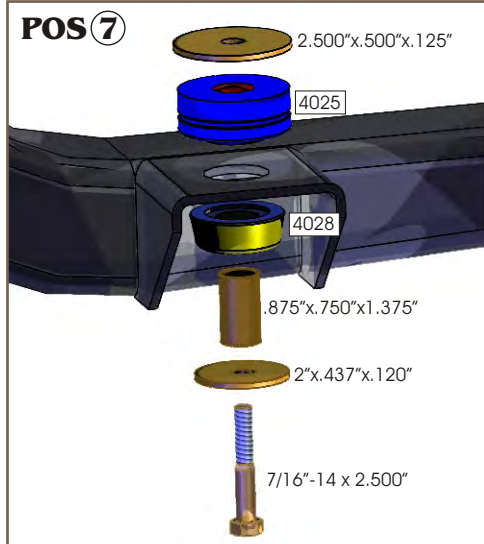

### POS ⑧

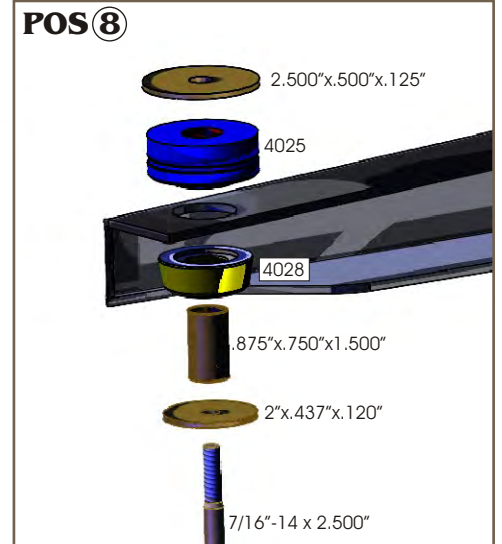

041106  
**17480**