



PART # 20140

INSTRUCTION SHEET

FRONT & REAR MOTOR KIT

FOR SMALL BLOCK CHEVROLET V-8 ENGINE & TURBO AUTOMATIC TRANSMISSION INTO CHEVROLET VEGA & MONZA, PONTIAC ASTRE & SUNBIRD, BUICK SKYHAWK & OLDSMOBILE STARFIRE

INSTALLATION INSTRUCTIONS:

NOTE: Please read carefully before starting installation.

1. Engine hoist should be used for this conversion. If hoist is not available, we strongly suggest the use of axle or jack stands for safety. Do not use bumper jack.
2. Remove stock engine, transmission and rear end.
3. Install front mounts to V-8 engine, using the top water pump holes, the original front mount holes and the 3/8" x 3" bolts included (**Tap 3/8"-16 if necessary - See illustration A**). You must use the "SHORT" water pump found on 1955-68 models.
4. Remove V-8 oil pan from engine and modify, so that it will clear steering. (**See illustration B.**)
5. Remove the idler arm and install the right-side mount, using the stock bolts and nuts to tighten. Weld along rear gusset. (**See illustration C.**)
6. Assemble engine and transmission. (Do not include starter at this time.)
7. Lower engine and transmission into place. Mark transmission tunnel and firewall for proper clearance around transmission. Remove engine and transmission. Modify transmission tunnel and firewall as necessary.
8. Again position engine and transmission. Make sure transmission is centered on chassis. Next, install the transmission mount, using stock Chevrolet transmission mount, either #3870182, #3870184, #3895830 or #3935704, any of which are acceptable as only difference is in the rubber compound. (**See illustration D.**)
9. Remove engine and transmission, modify and install starter. (**See illustration E.**) **NOTE: Make certain to use short starter (late model) such as Chevrolet #1108381, which bolts to the block. Or a starter which bolts directly to Ansen or Lakewood style bellhousing.**
10. Lower engine into position. Make sure everything is again centered. Install the transmission.
11. Install right-side motor mount assembly. Do not tighten at this time.
12. Check to be sure everything has remained centered. Install the left-side motor mount. (**See illustration F.**) **NOTE: Left side must be welded after engine is installed. Right-side mount weld (down sides) is optional.**
13. Install header system. A custom header system such as Hedman #68340 is suggested.
14. Check for sufficient clearance on headers. Engine may be relocated slightly, if necessary. Tighten all bolts.
15. If your car uses an automatic transmission, you may use a Hurst Dual Gate floor shift or similar unit which uses a cable.
16. If you are using a manual transmission, you must purchase the Trans-Dapt clutch cable bracket #20130. Also, purchase stock Chevrolet clutch cross shaft #3840836 from Chevrolet dealer.
17. If the heater is to be used, a short water pump heater hose nipple will be required to properly clear the front engine mount.

NOTE: This kit is offered only as an aid to making this conversion. It should be remembered that the Vega was designed to use a 4 cylinder engine and the installation of a V-8 can place unintended strain on other parts of the vehicle. Therefore, you should consider a late model narrowed rear end, heavy-duty springs or air cond. spacers in front to support the added weight, a larger fan or radiator (but check fan-blade clearance) and anything else which might take into consideration this modification.

ILLUSTRATIONS

Illustration A

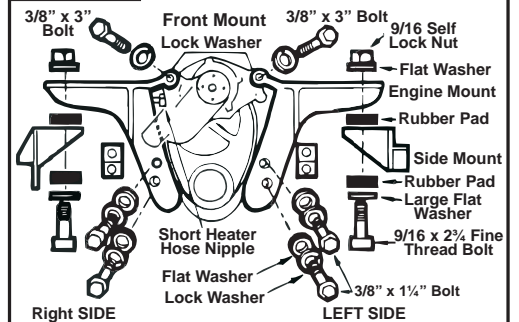

Illustration B

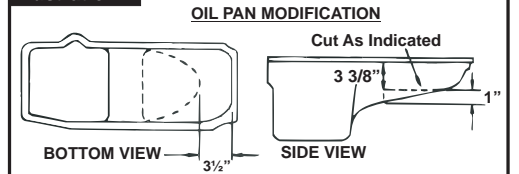

Illustration C

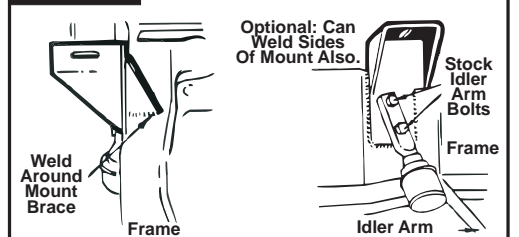

Illustration D

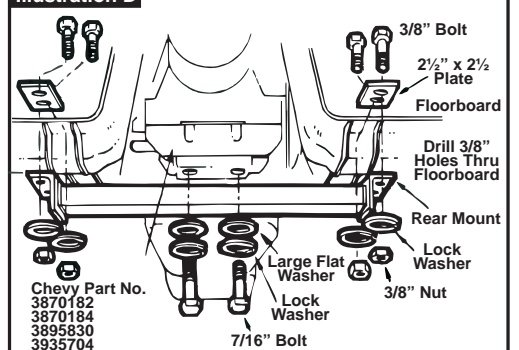

Illustration E

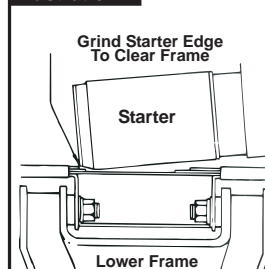

Illustration F

