





1. Frame Inspection .....	2
2. Frameset Parts .....	3
3. Headset Installation .....	5
4. Stem/Handlebar Installation .....	8
5. Front Brake Installation.....	16
6. Rear Brake Installation .....	20
7. Cable Housing Installation .....	22
8. Electronic Drive-train Specification .....	28
9. Seatpost Installation.....	32
10. Saddle Adjustment .....	33
11. Derailleur Hanger Adjustment.....	34
12. Frameset Parts Checklist .....	36

<p><b>My Nitrogen Pro</b></p> <p>Date of purchase: _____</p> <p>Retailer: _____</p> <p>Size: _____</p> <p>Serial Number: _____</p>
--

*For the warranty to be valid, the bicycle must be fully assembled by an authorized Argon 18 dealer. High end components, particularly carbon parts, need extra care when assembled. These components must be installed using a calibrated torque wrench to make sure every bolt is at the right torque setting to prevent damage.*



BEFORE ASSEMBLING YOUR NEW NITROGEN PRO, MAKE SURE THAT YOU HAVE ALL THE FOLLOWING:

1. Brakes and gears cables and housing set
2. Frameset parts checklist (see p.36)
- 3: Inspect the frame for cosmetic aspect (scratches, bumps, cracks, paint defect, etc.)
- 4: For reference, check serial number and write it on p.1
- 5: All the necessary bolts (refer to Frameset Parts, p.3)
- 6: For optimal shifting performance, use a dropout alignment gauge to make sure that the drive-side dropout is straight (p.35)

**IMPORTANT:**

**The following parts are assembled on the frame. When assembling the bike, you will need to adjust these parts according to their torque specifications.**

Parts installed on the frame		Description	Screw type	Tork Nm	Detail
1	Front derailleur hanger	Screw (2)	3mm	4Nm	Loctite
2	Rear derailleur hanger	Screw (2)	3mm	4Nm	Loctite
3	Bottle cage	Screw (4)	4mm	3Nm	Grease
4	Bottom bracket cable guide	Screw	5mm	1.5Nm	Grease

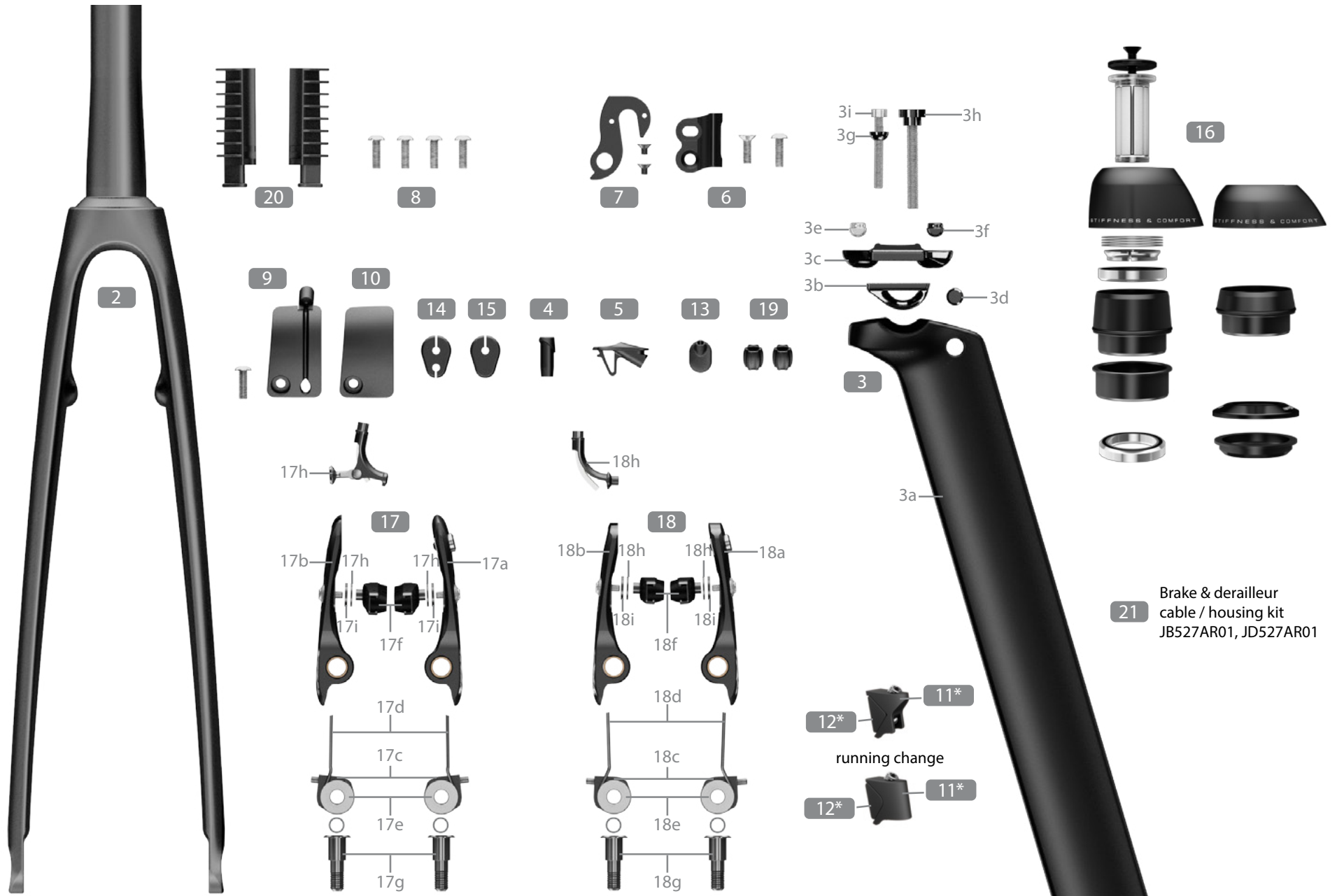

Images are for reference only. Proportions are not accurate.  
 Argon 18 reserves the right to modify/change parts of the frameset at any moment without prior notice.  
 \*For more info please consult notice on Seatpost clamp dated 2016-06-09

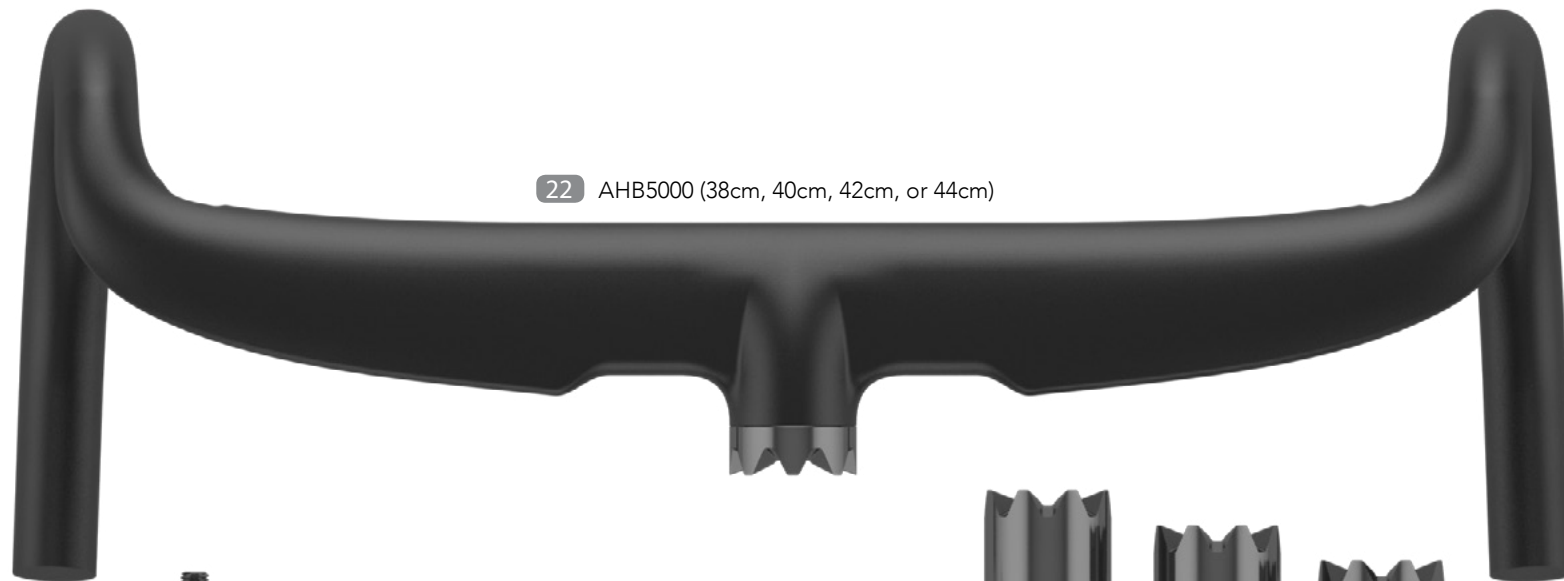

22 AHB5000 (38cm, 40cm, 42cm, or 44cm)



Washer  
M8  
23

Screw  
M8x50mm  
24

Screw  
M8x30mm  
25

Elastic Cover  
Small  
26

Elastic Cover  
Large  
27

Spacer  
20mm  
28

Screws  
M5x16mm  
29

Stem A.03  
Large  
30

Stem A.02  
Medium  
31

Stem A.01  
Small  
32

Frameset Size	Handlebar Width				Stem Size			20mm Spacer
	38	40	42	44	Small	Medium	Large	
X-Small		●			●	●		●
Small			●		●	●		●
Medium				●		●	●	●
Large				●		●	●	●
X-Large				●		●	●	●

**Notes:** 38cm Handlebar is only available aftermarket.  
If you wish to purchase the third non-included stem, you can do so by ordering it as a spare part

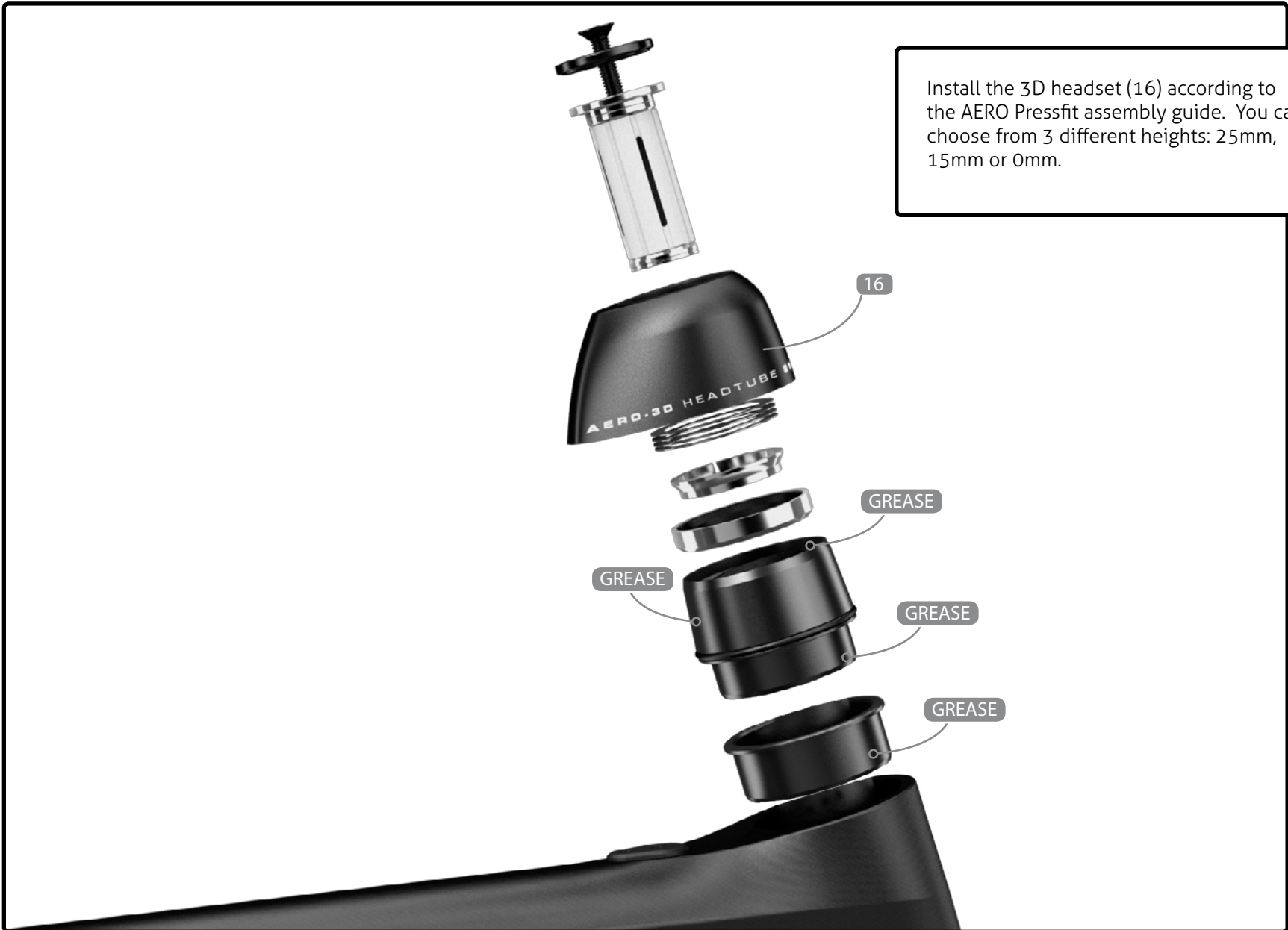

Install the 3D headset (16) according to the AERO Pressfit assembly guide. You can choose from 3 different heights: 25mm, 15mm or 0mm.



## STEP 1

First, you must assess which setup suits your needs: **25mm, 15mm or 0mm.**

## STEP 2

Inspect the bike's head tube for any sharp edges and apply a small amount of grease.

## STEP 3

For the **25mm and 15mm** setups, lightly grease the bottom section of the 3D bearing holder (6) and insert the plastic sleeve (7).

Position the headset inside the head tube. Place the top 3D assembly with the headset bearing inside (this will prevent the sleeve from getting damaged). Add the compression ring on top of the bearing, then add the press fit 3D system tool and softly press down the assembly until it bottoms out using a Bearing Cup Press (**Park Tool HHP-2**). Then, insert the bottom bearing (5), compression ring (4) micro spacers (3) and top cap (2), slide the fork and stem and measure the steerer length needed.

For the **0mm setup**, do not use the plastic sleeve. Install the 3D bearing holder (6) with grease applied directly inside the frame.

## STEP 4

To remove the 3D bearing holder, insert the **Park Tool RT-1** and then tap it carefully until the spacer comes out.

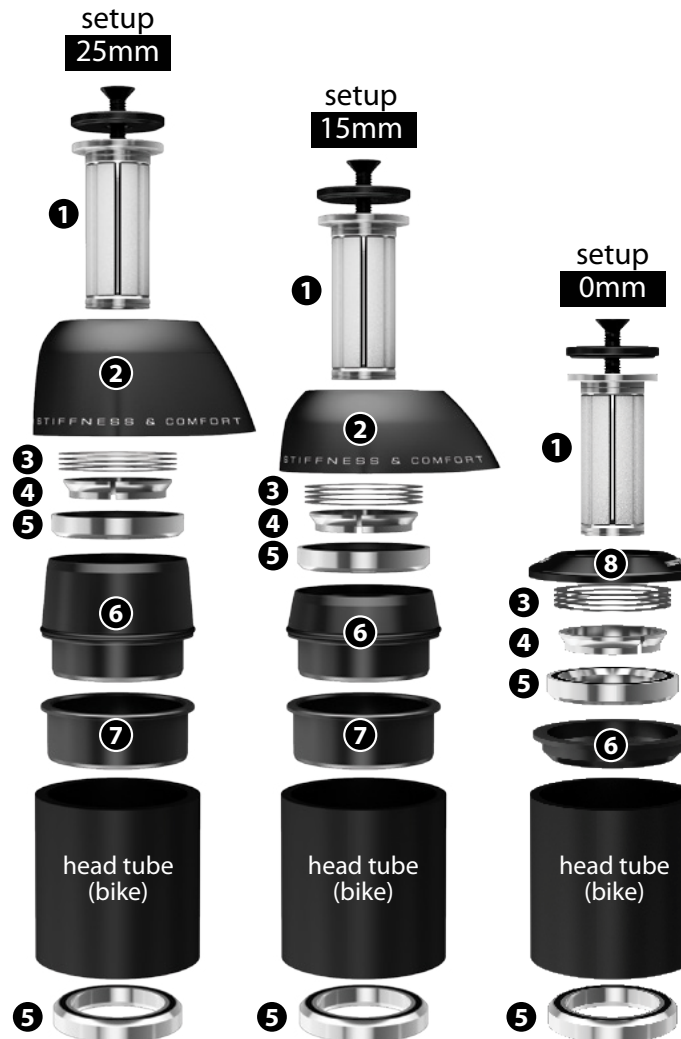

- 1 Compressor
- 2 Top cap (including O-ring & seal)
- 3 Micro spacers
- 4 Compression ring
- 5 Bearing
- 6 3D bearing holder
- 7 Plastic sleeve (no need for 0mm setup)
- 8 Top cap for 0mm setup



  
IMPORTANT: Use the Press Fit 3D system tool 1 1/2" with the Bearing Cup Press (ParkTool HHP-2) to avoid any damage on the bike frame.

- ❶ Compressor
- ❷ Top cap (including O-ring and seal)
- ❸ Micro spacers
- ❹ Compression ring
- ❺ Bearing
- ❻ 3D bearing holder
- ❼ Plastic sleeve (no need for **0mm** setup)
- ❽ Top cap for **0mm** setup

Press Fit 3D system tool 1 1/4"

Bearing Cup Press (**Park Tool HHP-2**)



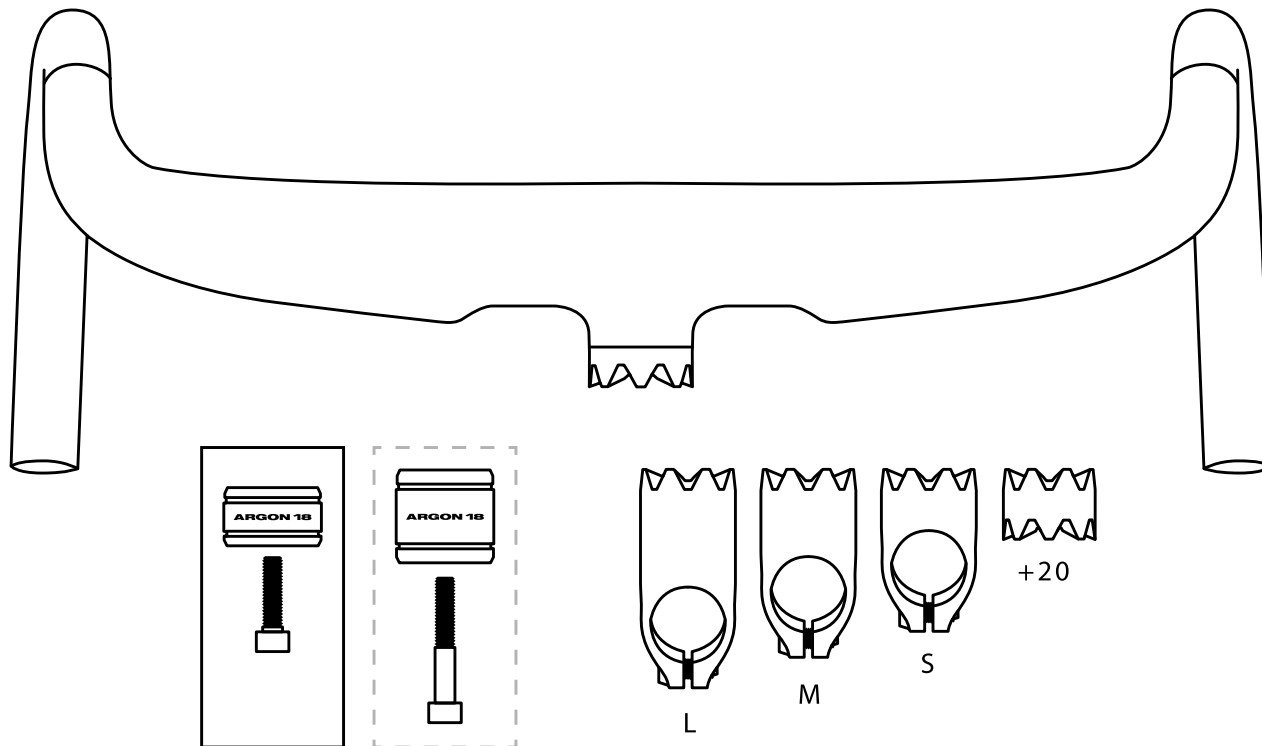



Failure to use long screw when assembling bar with +20mm spacer of any configuration can lead to serious injury

## CONFIGURATION MATRIX

	Stems size (stems included)			
	S	M	L	20mm spacer
38	70mm	80mm	*(110mm)	●
40	80mm	90mm	*(100mm)	●
42	*(80mm)	90mm	100mm	●
44	*(90mm)	100mm	110mm	●

\*Requires the purchase of an additional stem from the ones included in basic assembly.



If you wish to purchase the third non-included stem, you can do so by ordering it as a spare part.

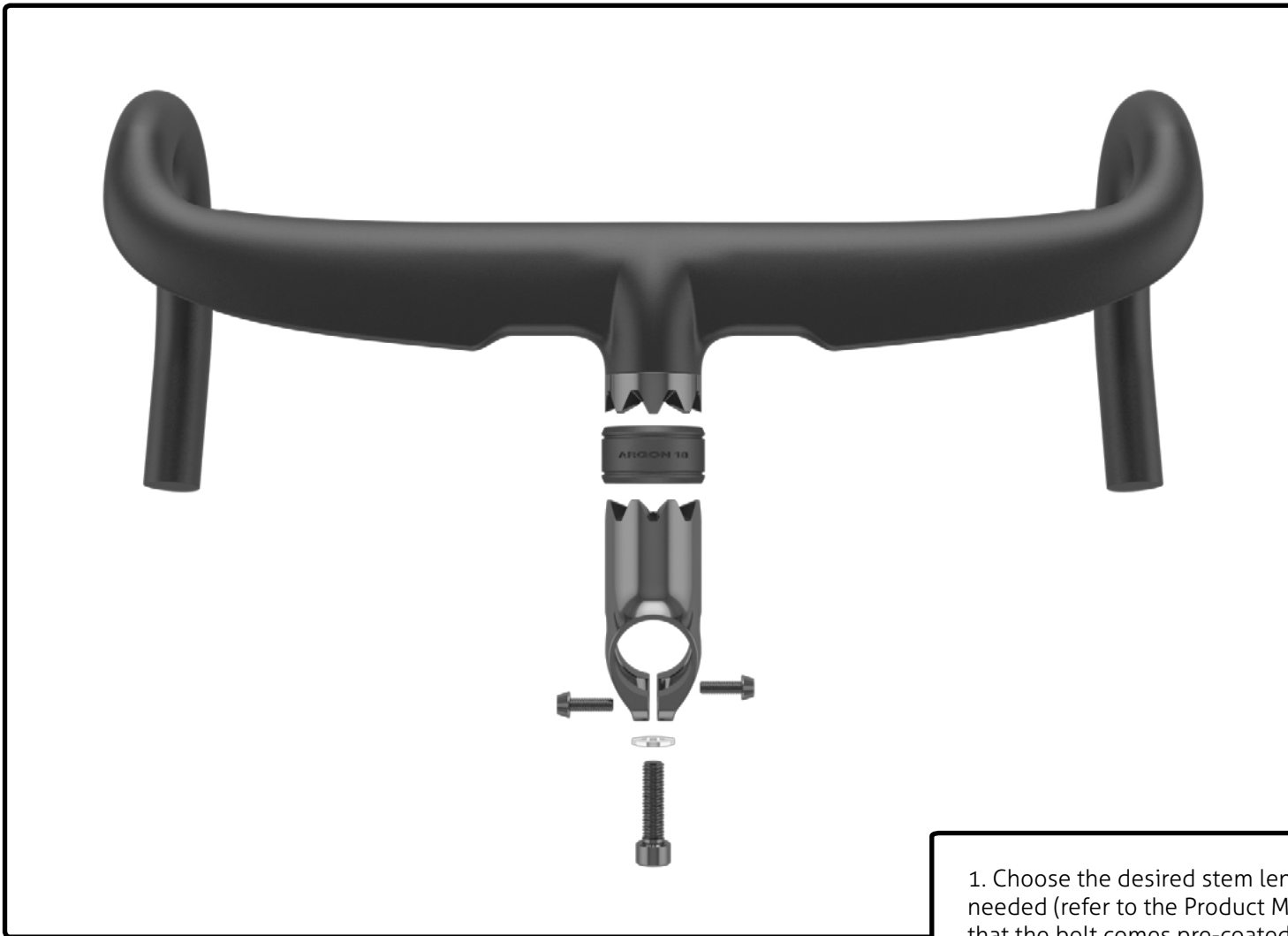

1. Choose the desired stem length, bolt, and spacer needed (refer to the Product Matrix chart on p.X) – note that the bolt comes pre-coated with Loctite. In the event of assembling and disassembling, one drop of blue Loctite (#242 or #243) must be applied on the bolt threads.

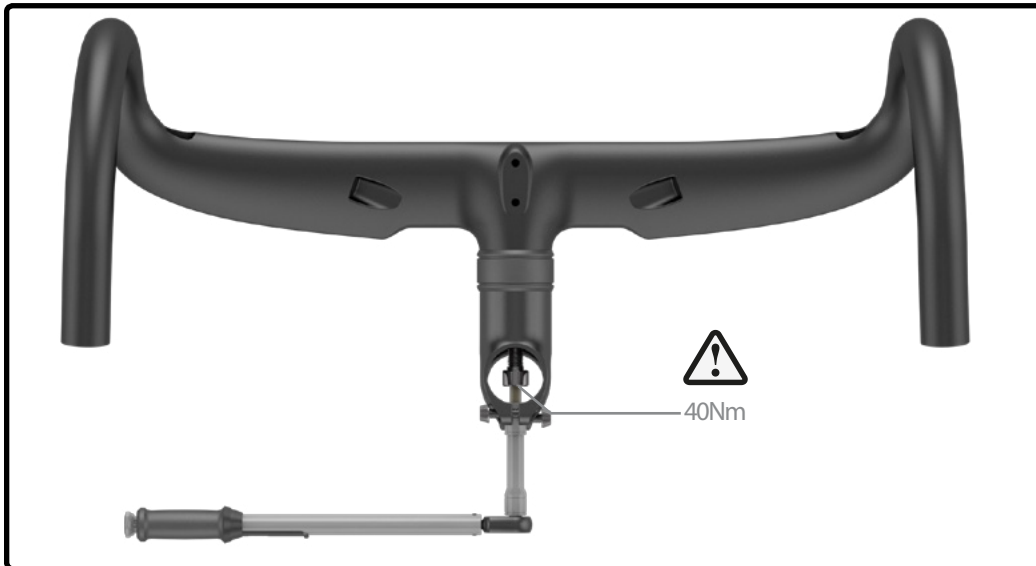

2. Place the elastic cover on the stem and the spacer with the Argon 18 logo facing up.

3. Place the handlebar upside down on a clean rag.

4. With the correct spacer and stem length using a torque wrench, a ratchet extension, and a 6mm bit thread the bolt and spacer up to 40Nm.

5. For easier handling and to prevent damage to the handlebar we recommend holding it down firmly while tightening.



**IMPORTANT:**

*If the appropriate torque (40Nm) is not reached and if Loctite is not applied the handlebar could loosen. Argon 18 cannot be held accountable if this is not measured.*



Place the handlebar on the fork and secure the stem/combo with the two side bolts to 5Nm.

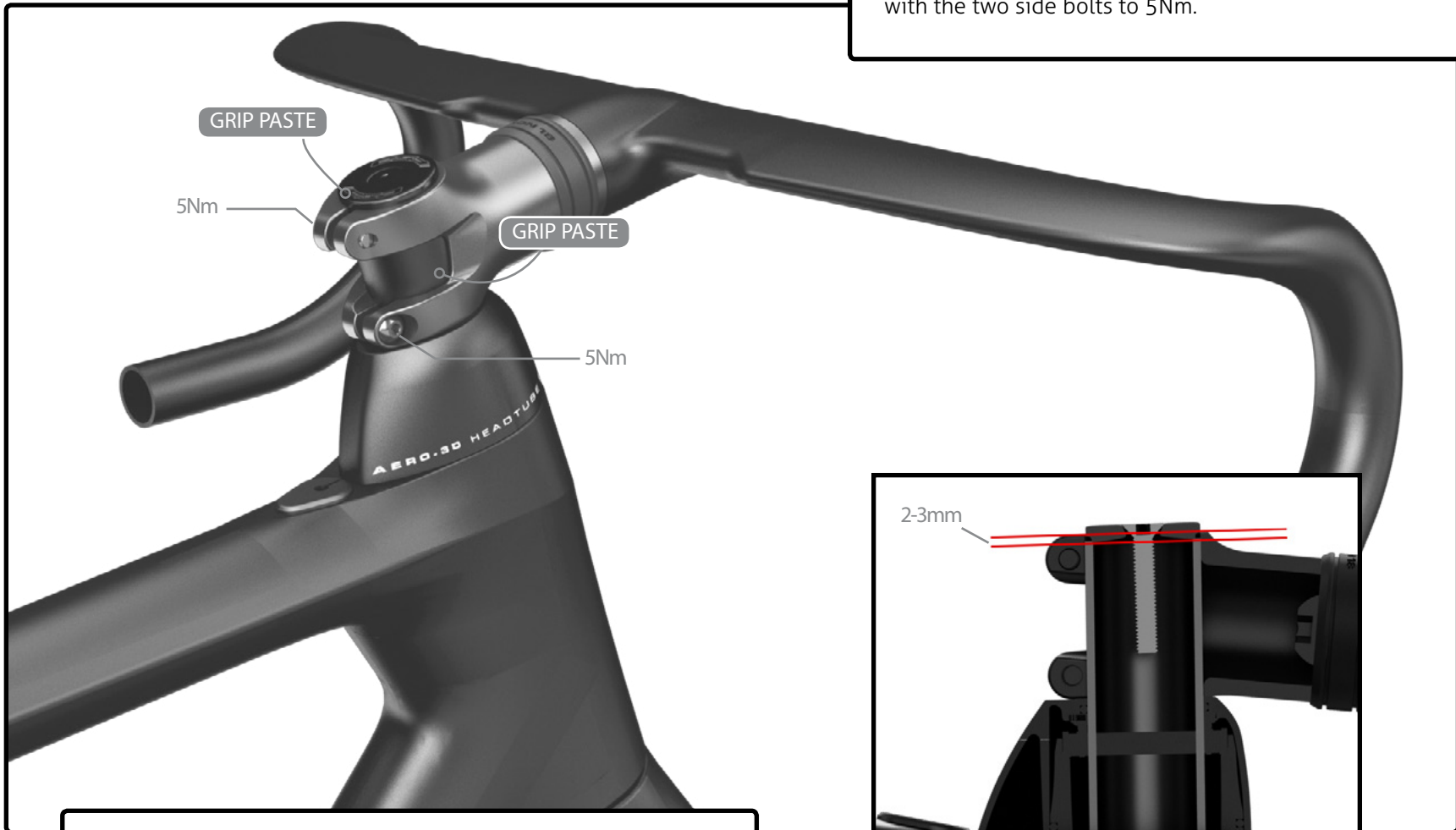

Note: When cutting the fork, allow 2mm or 3mm of additional space between the compressor cap and the fork in order to obtain sufficient compression of the headset.



**⚠** *Electronic Shifting*  
*Important: Always pass the electronic cables before the brake housing; the opposite would make it very difficult to get the electronic cables through after the brake housing.*



1. Install the brake hood to the desired height and make a mark with a white pen.

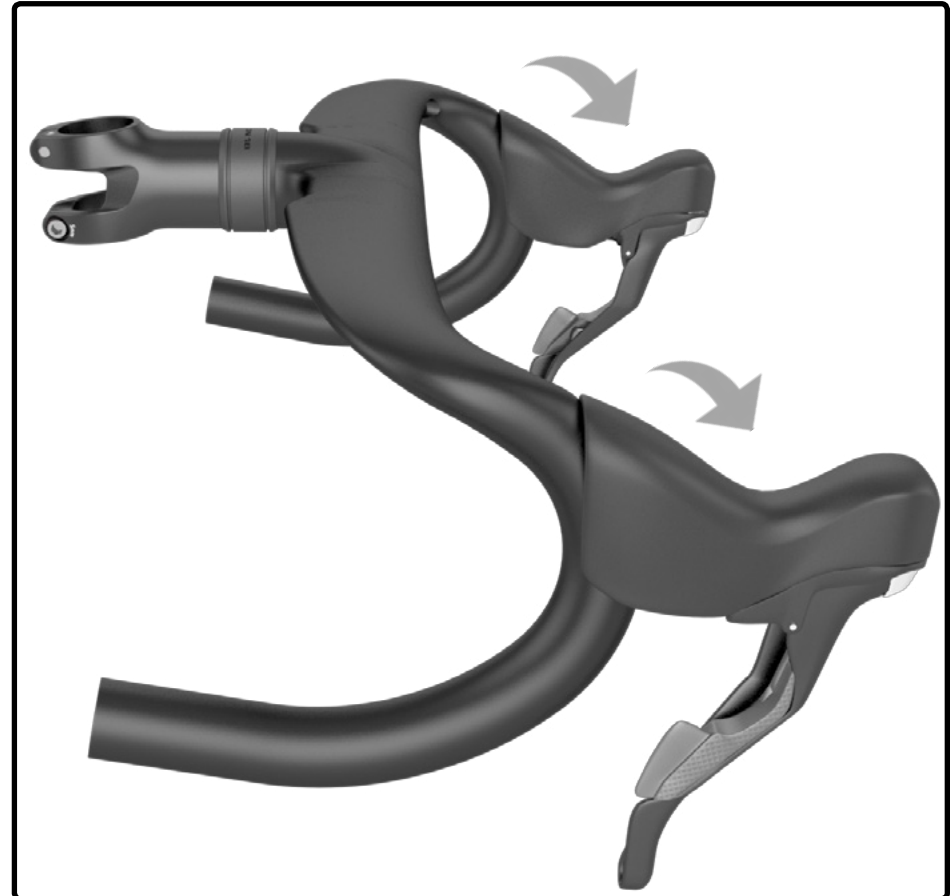

2. Lower the shifter assembly.

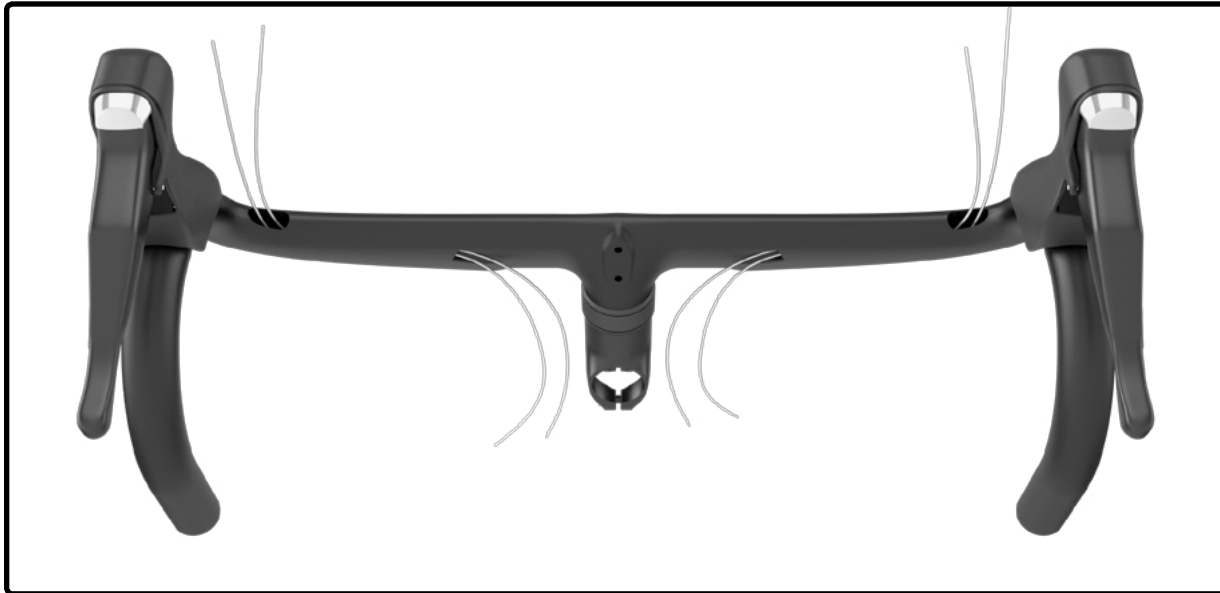

3. Fish two cables inside the handlebar on each side.

4. Select the length of necessary housing and pass both at the same time.

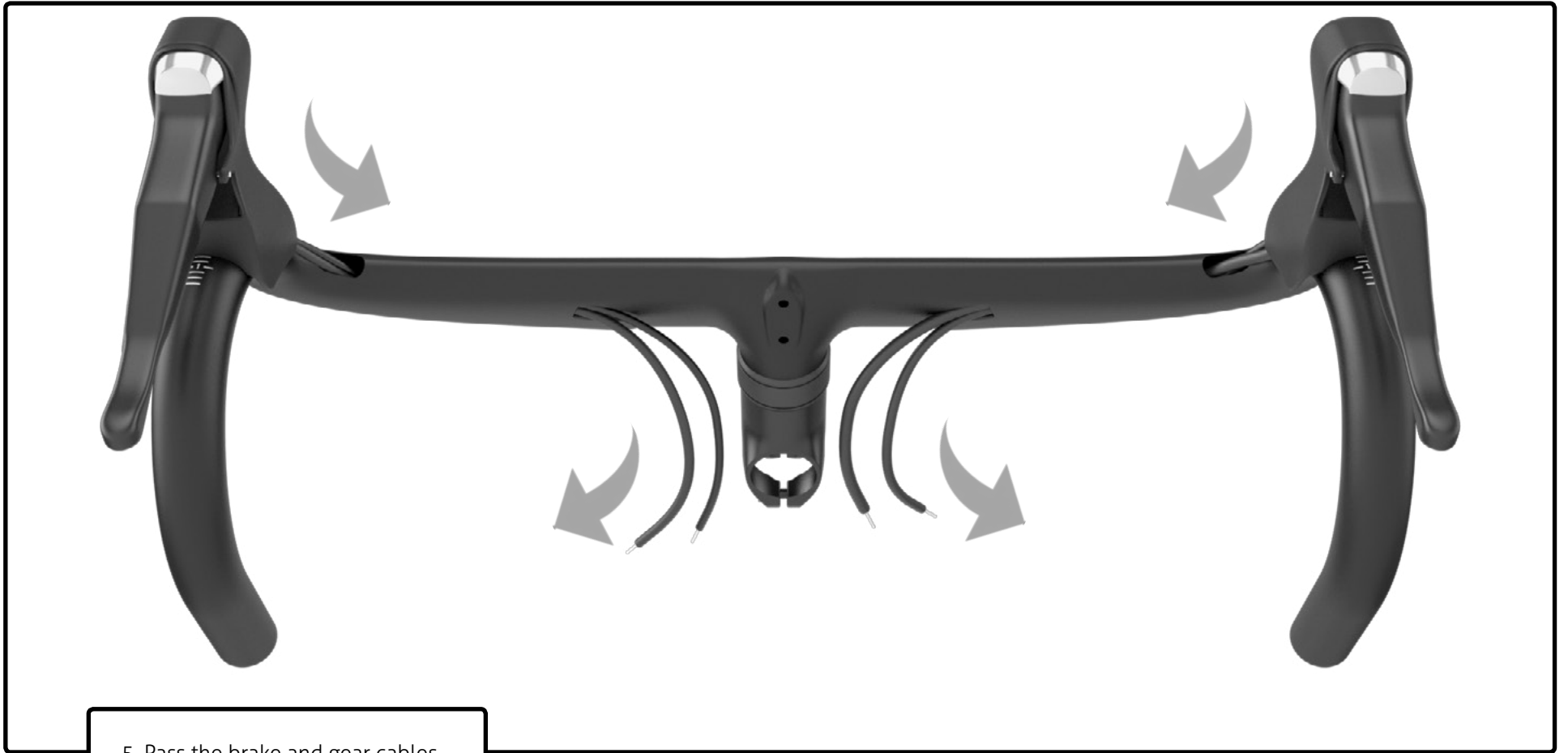

5. Pass the brake and gear cables in the shifter body.

6. Connect cables to housing and put the levers back to the white mark on the handlebar.

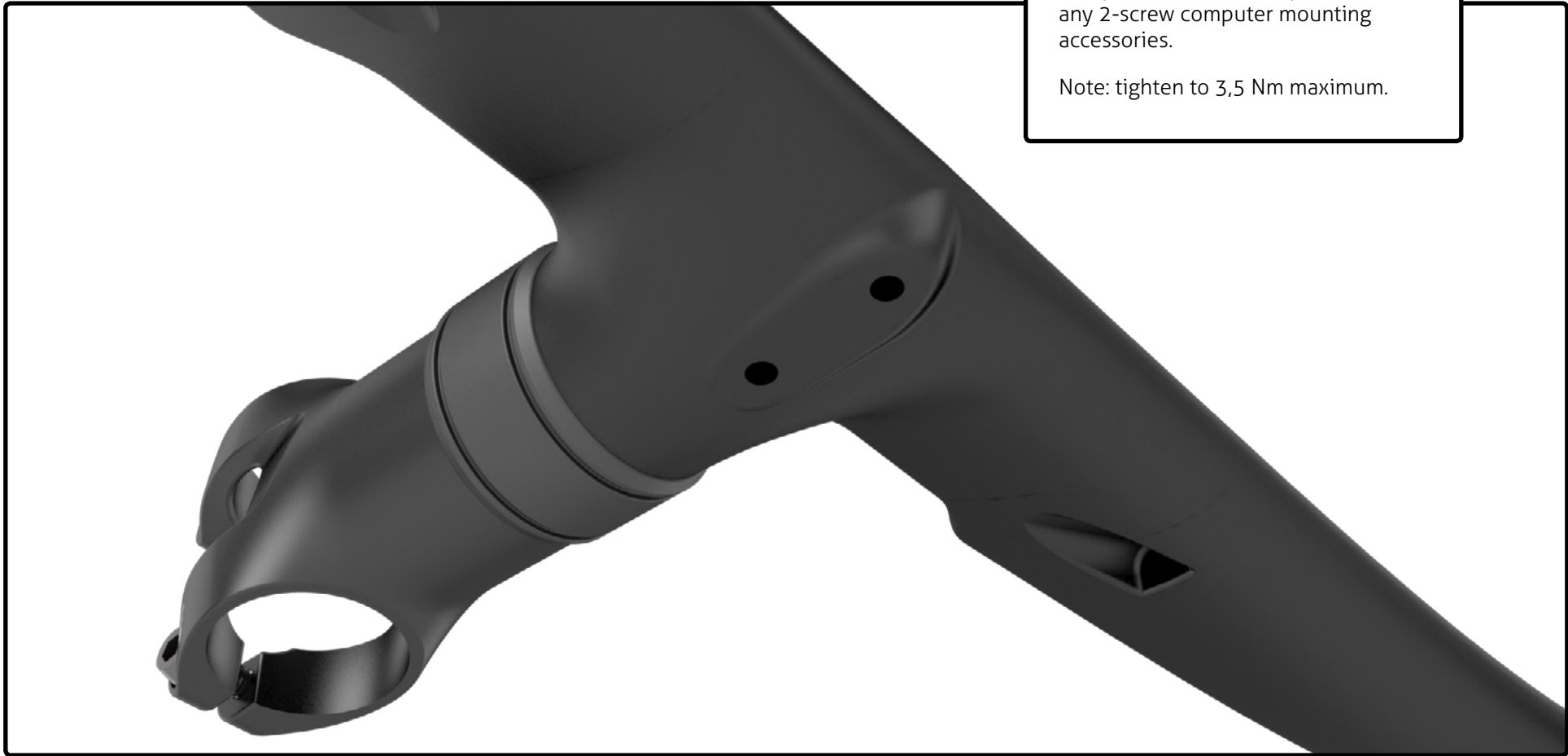

Computer mount is compatible with any 2-screw computer mounting accessories.

Note: tighten to 3,5 Nm maximum.



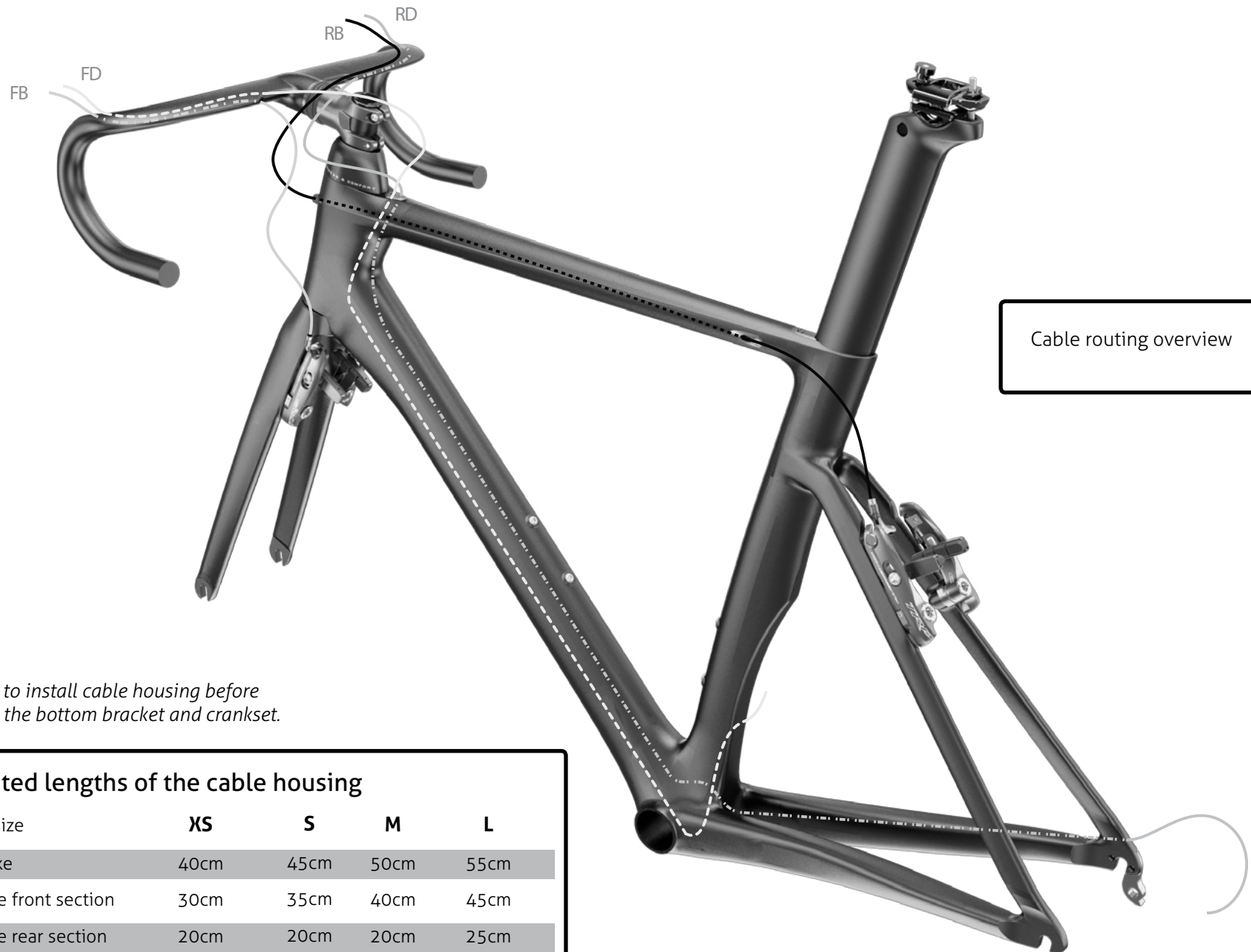

*It's better to install cable housing before installing the bottom bracket and crankset.*

### Suggested lengths of the cable housing

housing/size	XS	S	M	L
Front brake	40cm	45cm	50cm	55cm
Rear brake front section	30cm	35cm	40cm	45cm
Rear brake rear section	20cm	20cm	20cm	25cm
Front derailleur	110cm	110cm	120cm	125cm
Rear derailleur	185cm	190cm	195cm	200cm





1. Pass the cable through the curved straw and then in the appropriate guide.
2. Fix the cable to the caliper with the 6mm screw and tighten it to 6Nm.





**IMPORTANT:** If the brake pad spacing is too thick, the brake arm can rub on the frame down tube. Make sure the pad spacing is appropriate.

Adjust brake pads according to the width of your rims:

- You can configure the brake pad spacers with 1mm (17h), or 2mm (17i) depending of the rim width you are using.

**Spacers required according to the rim width**

Rim width	Spacer combinaison
19mm (e.g.: Shimano C50)	2mm spacer
24mm + (e.g.: 808 clincher/Enve)	1mm spacer (thin pad may be required)

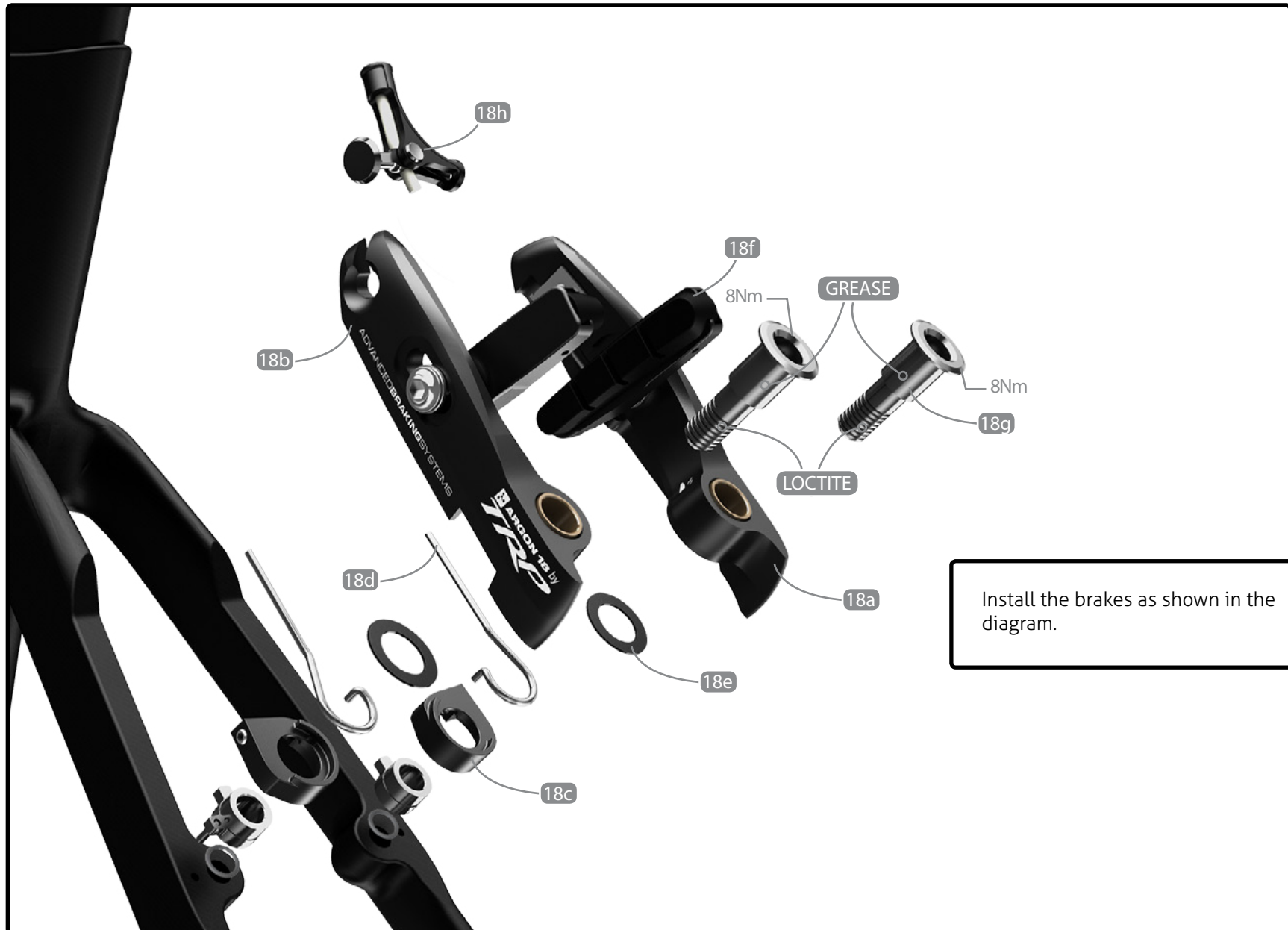

Install the brakes as shown in the diagram.



1. Adjust brake pads according to the width of your rims:
2. Pass the cable through the cable guide. Make sure that the length of the cable housing is sufficient for the guide to remain horizontal as it can cause interference with the rear wheel tire.
3. Use the proper brake pad spacers depending on the width of your wheel rims.
4. Fix the cable to the caliper with the 6mm screw and tighten it to 6Nm.

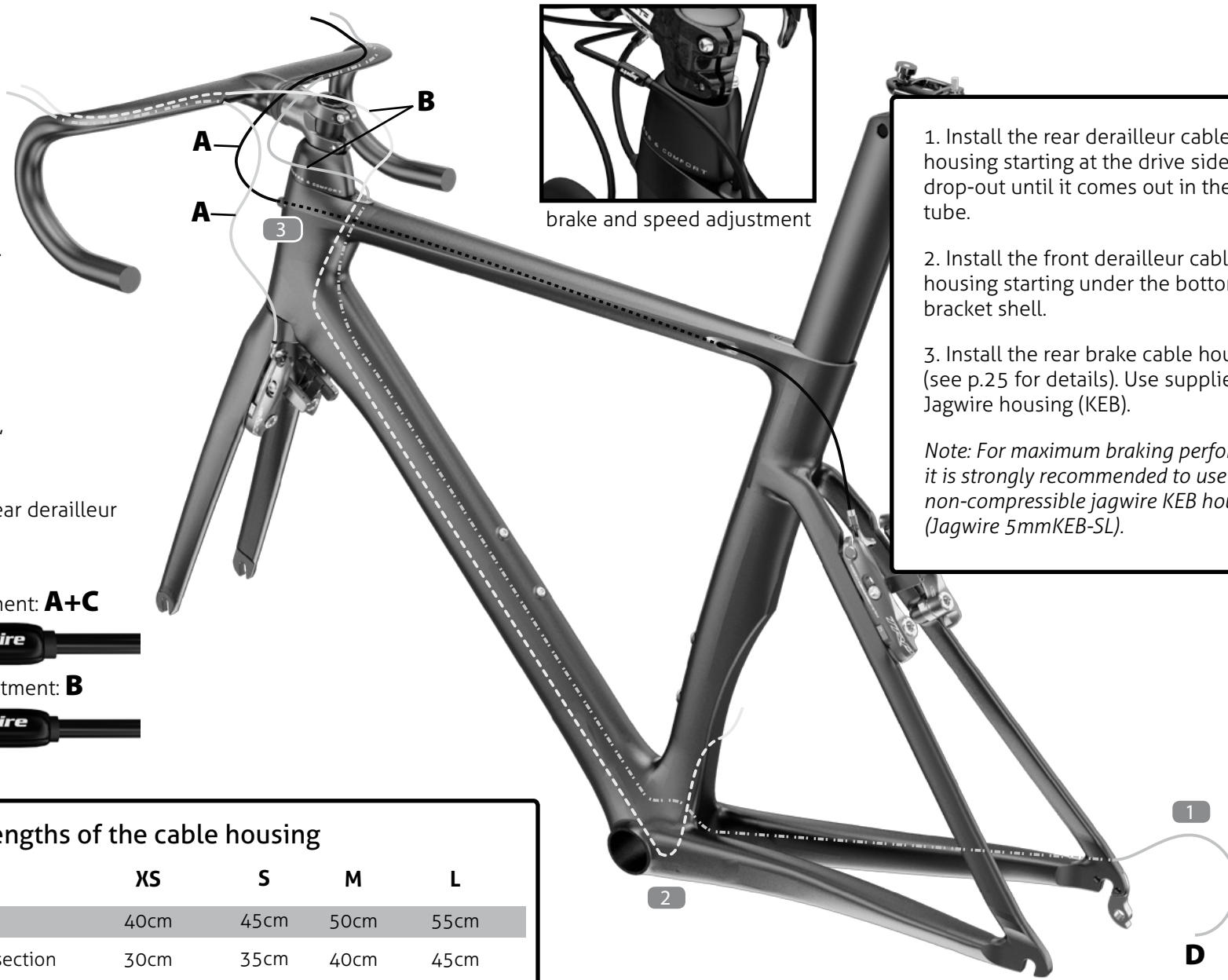

brake and speed adjustment

1. Install the rear derailleur cable housing starting at the drive side's drop-out until it comes out in the top tube.
  2. Install the front derailleur cable housing starting under the bottom bracket shell.
  3. Install the rear brake cable housing (see p.25 for details). Use supplied Jagwire housing (KEB).
- Note: For maximum braking performance it is strongly recommended to use the non-compressible jagwire KEB housing (Jagwire 5mmKEB-SL).*

**A:** 5mm barrel adj.



**B:** 4mm barrel adj.



**C:** metal cap "pop"



**D:** metal cap for rear derailleur



brake adjustment: **A+C**



speed adjustment: **B**



Suggested lengths of the cable housing	XS	S	M	L
Front brake	40cm	45cm	50cm	55cm
Rear brake front section	30cm	35cm	40cm	45cm
Rear brake rear section	20cm	20cm	20cm	25cm
Front derailleur	110cm	110cm	120cm	125cm
Rear derailleur	185cm	190cm	195cm	200cm

*It's better to install cable housing before installing the bottom bracket and crankset.*



*Note: The front brake cable guide (17h) should be front-oriented to ensure good rotation of the handlebar.*



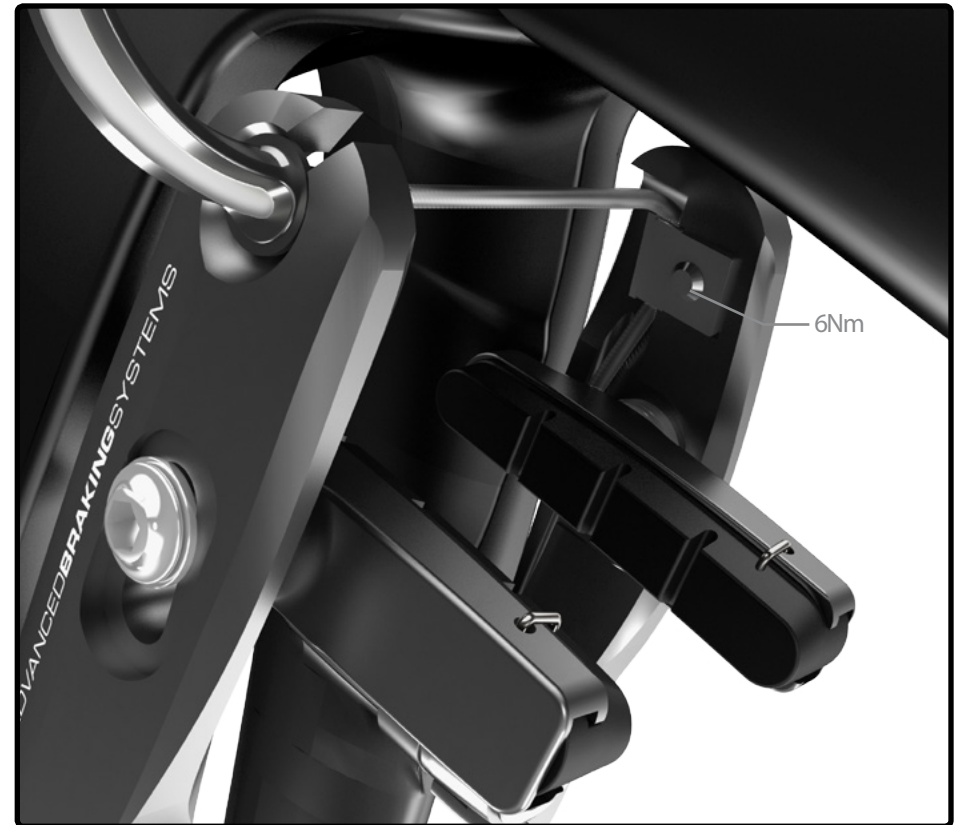

## Front brake

Pass the cable through the cable guide (17h).

Create a "hook" with the cable; it will be easier to pass it inside the retainer nut.

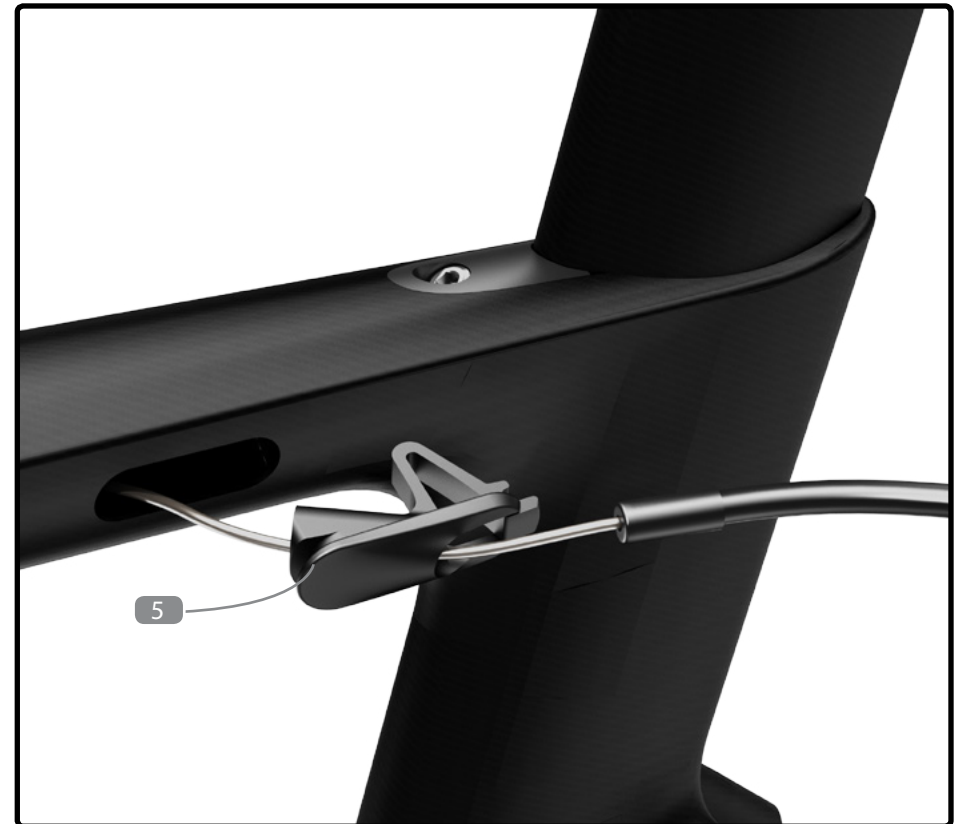
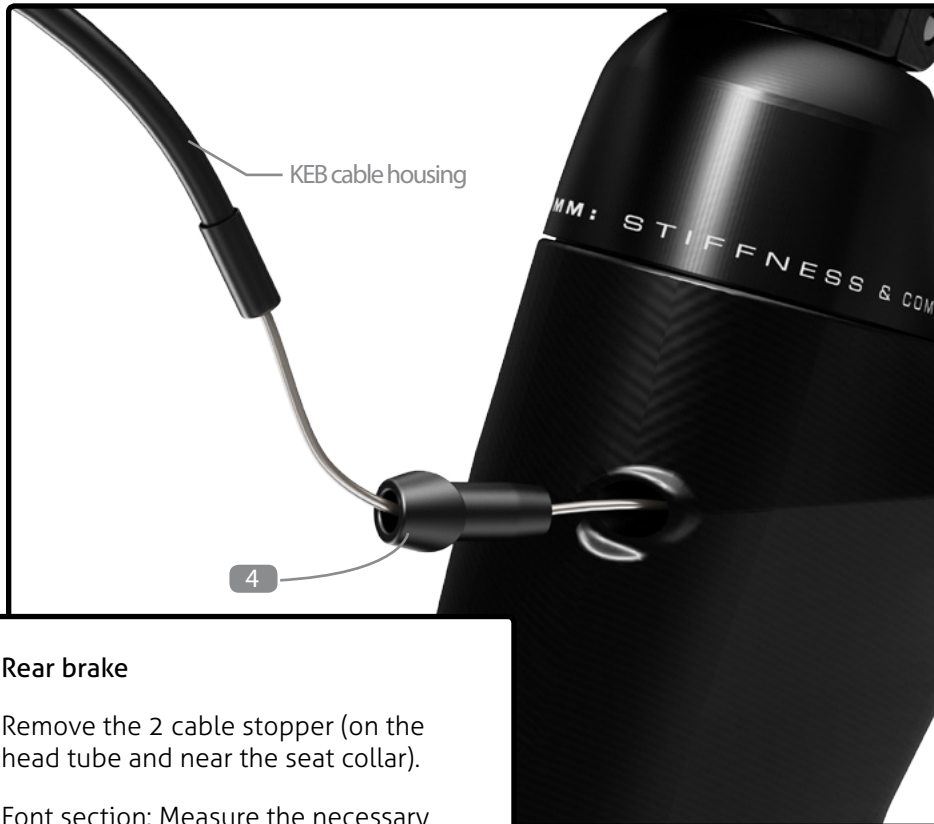

### Rear brake

Remove the 2 cable stopper (on the head tube and near the seat collar).

Font section: Measure the necessary cable housing to ensure proper rotation of the handlebar. Insert the "KEB" cable housing and the cable trough the top tube.

Rear section: With a magnet, get the rear brake cable out of the frame, and pass it through the rear cable stopper. Measure the "KEB" rear housing correctly to avoid interference with the rider's left leg.



*Note:*

*It's better to install the cable housing before installing the bottom bracket and crankset.*

Rear derailleur: Pass the cable housing inside the frame starting at the rear derailleur hanger until it comes out the top tube.

Front derailleur: Remove the cable guide (9) under the bottom bracket. Pass the cable housing inside the downtube until it comes out the top tube.

Add a plastic cap at the end of the housing, pass the rear derailleur cable inside the housing and fix the cable guide under the bottom bracket with the 5mm screw (1.5 Nm).

For a Di2 configuration, use the bottom bracket dedicated cover (10) for electric shifting.



Use the provided grommet (19) to correctly set the rear derailleur cable housing in the chainstay (mechanical drive-train only).

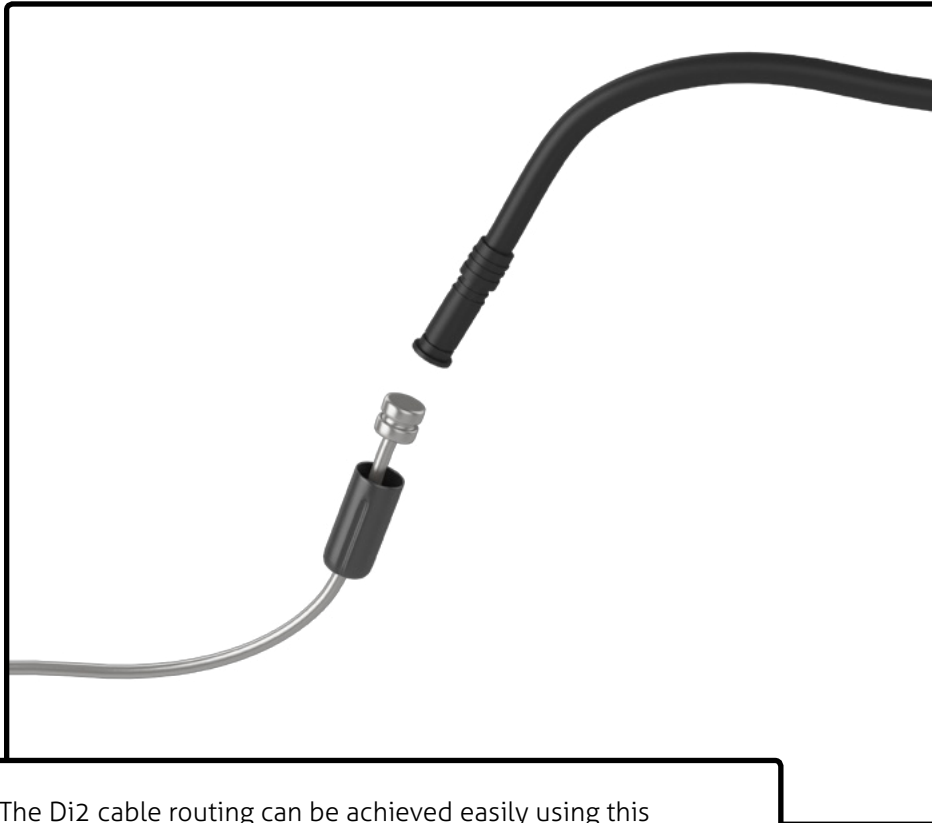

The Di2 cable routing can be achieved easily using this simple trick: use a gear cable and a metal cable end to fix the Di2 cable. For more information on Shimano Di2 electronic system installation, go to: [si.shimano.com](http://si.shimano.com).



Use the proper grommet on the top tube to fix the cable correctly (depending if you use electronic shifting or mechanical drive-train).



When using an electronic drive-train, use the grommet (13) to fix the front derailleur cable.

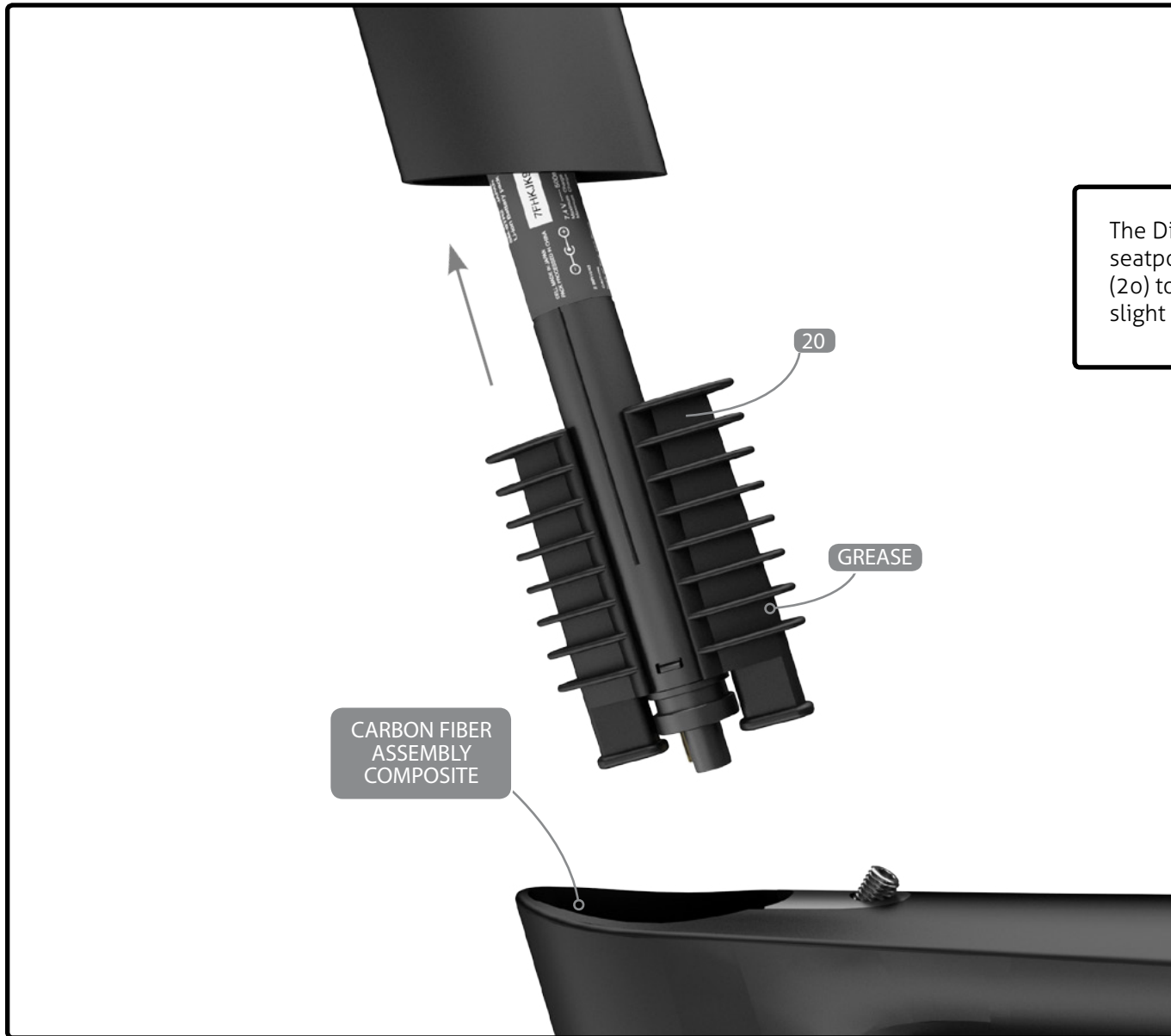

The Di2 battery is hidden in the seatpost; use the Di2 battery holder (20) to fix the battery correctly. Apply a slight amount of grease on both parts.





## RUNNING CHANGE

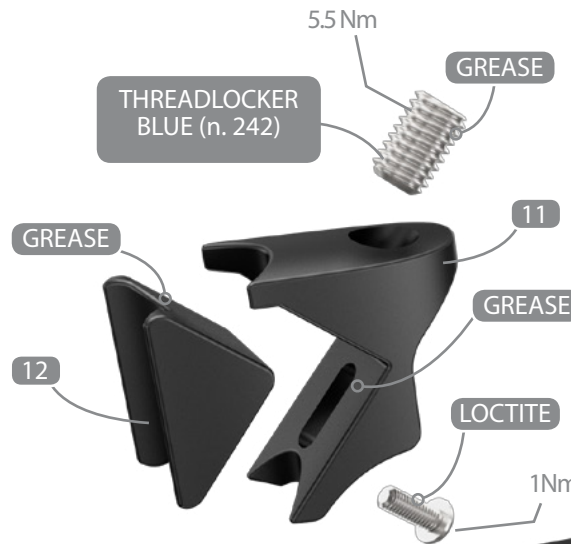

1. Place the seat post collar inside the frame.
2. Insert the seatpost (3) on which some carbon fiber assembly gel has been applied.
3. Position the seatpost to the desired height.
4. Apply a drop of blue Threadlocker (n. 242) on the bolt's thread
5. Tighten the set screw at max. 5.5Nm while leaving a space between the two parts allowing them to slide.



1. Install the saddle on the rocker (3b) and tighten the rail clamp (3c) up to 6Nm using the half-moon bolt (3i).
2. Adjust the angle and the offset of the saddle by hand tightening the thumb screw (3h).
3. The rocker (3d) can be flipped to change the saddle offset (+ / - 5mm).



The front derailleur hanger (6) can be adjusted according to the front derailleur angle to get an equal curve between the derailleur and the big chain ring. Once at the right angle, use blue 242 Loctite and screw both screws in at 4Nm.

LOCTITE

LOCTITE

6

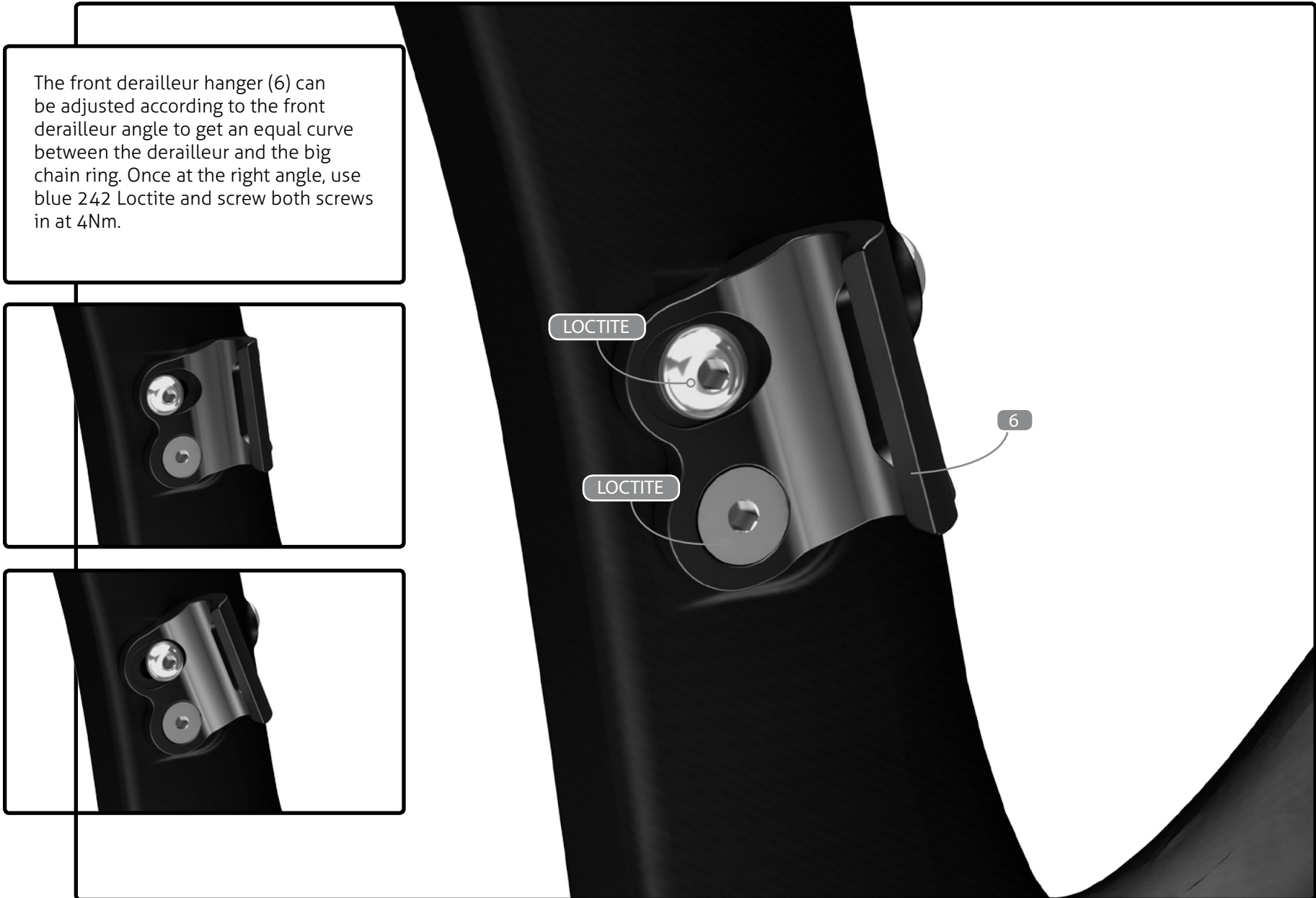



1. Ensure that the dropout is aligned.

2. Use Derailleur Hanger Alignment Gauge like Park Tool Item # DAG-2.

For any assistance, visit Park Tool's website:  
[parktool.com/product/derailleur-hanger-alignment-gauge-dag-2](http://parktool.com/product/derailleur-hanger-alignment-gauge-dag-2)



No.	Name	A18 SKU#	Qty
<b># Frameset Parts</b>			
1	Nitrogen Pro MY2016 Frame		1
2	Nitrogen Pro MY2016 Fork	FK.NITPRO.230A	1
<b># Seat post with the following parts assembled</b>			
3	Nitrogen pro seat post (ASP-5100)	SP.NITPRO.230A	1
3a	AG-SP-02 carbon part		1
3b	Lower Rail Clamp		1
3c	Upper Rail Clamp		1
3d	Half Moon Nut M6		1
3e	Half Moon Nut M5		1
3f	Half Moon Bolt		1
3g	Spherical Washer M5		1
3h	M6 Thumbscrew		1
3i	M5x40mm socket head		1



No.	Name	A18 SKU#	Qty
<b># Frame related parts already installed</b>			
4	Head tube brake cable stopper	38878	1
5	Top tube brake cable stopper	38879	1
6	Front derailleur hanger with screws	38882	1
7	Rear derailleur hanger with Flat Head screws (M3*8mm)	38883	1
8	Water bottle screw	38884	4
9	BB cable guide with Round Head Philips screws (M5*10mm)	38885	1
10	BB cover for elec. shifter with Round Head Philips screws (M5*10mm)	38260	1
<b># Seat collar</b>			
11	Seat collar base with screw M8x12mmF	80375, 80478	1
12	Seat collar wedge with screw M3x8mmB	80374, 80477	1



No.	Name	A18 SKU#	Qty
<b># Di2 configuration specific parts</b>			
13	FD cable grommet for Di2	38888	1
14	Top tube grommet Non-Di2	38880	1
15	Top tube grommet for Di2	38881	1
<b># Also Included with the frameset - shipped separately</b>			
16	Headset with compressor TH-881-	38724	1
17	Rear brake assembly	38719	1
18	Front brake assembly	38720	1
19	Grommet for chainstay	39009	1
20	DI2 battery holder for aero SP	38757	2



No.	Name	A18 SKU#	Qty
<b>#</b>	<b>Also Included with the frameset - shipped separately</b>		
17	TKB137 front brake including the following parts	38719	
17a	Brake Arm right		
17b	Brake Arm left		
17c	Brake pivot		
17d	Spring tensionners		
17e	Washers		
17f	Brake pad		
17g	Pivot bolt		
17h	cable guide	80425	
17i	2mm spacer		2
17j	1mm spacer		2
18	TKB138 rear brake including the following parts	38720	
18a	Brake Arm right		
18b	Brake Arm left		
18c	Brake pivot		
18d	Spring tensionners		
18e	Washers		
18f	Brake pad		
18g	Pivot bolt		
18h	cable guide	80424	
18i	2mm spacer		2
18j	1mm spacer		2





No.	Name	A18 SKU#	Qty
#	<b>Also Included with the frameset - shipped separately</b>		
21	Brake cable / housing kit including the following parts	39014	
	Housing 5mmKEB-SL		1
	End caps		2
	End caps		1
	End caps		2
	Cable		2
	Barrel adjuster		2
	Derailleur cable / housing kit including the following parts		
	Housing LEX40-SL		1
	End caps		2
	End caps		2
	Cable		2
	Barrel adjuster		2



No.	Name	A18 SKU#	Qty
<b>#</b>	<b>AHB5000 Handlebar parts</b>		
22	AHB5000 - 38cm	80073	1
	AHB5000 - 40cm	80074	1
	AHB5000 - 42cm	80075	1
	AHB5000 - 44cm	80076	1
23	Washer M8	80034	1
24	Screw M8x50mm	80030	1
25	Screw M8x30mm	80029	1
26	Elastic Cover Small	80162	1
27	Elastic Cover Large	80163	1
28	Stem Spacer 20mm	80104	1
29	Screw M5x16mm	80028	2
30	Stem A.03 Large	80105	1
31	Stem A.02 Medium	80106	1
32	Stem A.01 Small	80107	1