

ENRICO MARONE CINZANO
FURNITURE

VALET

VALET



VALET

Clothing has always been part of Chinese culture as a means of cultural, status and personal definition. As one dynasty got replaced by another, the overall garb did too. This is especially evident later in history with the advent of Communism, where everyone conformed to the ideology to the maximum possible extent, the outfit being practically similar even between men and woman, regardless of ranking within the social or governmental structure. With the advent of Chinese-style Social Capitalism a new trend emerged, and fashion became the most pedestrian way to display one's achievements. It also brought a complete assimilation of inspiration drawn from the West and fashion and attention to detail. You walk the streets of any large Chinese city and you can spot, as time progresses, a definite coolness in style, most evident in those with the most advanced taste. Hence my Valet: the perfect dressing room companion for the elegant one who plans their daily dressing. 100% Italian design, 100% Chinese made, with locally sourced reclaimed wood treated with natural oils, fully handcrafted and built with secret compartments.

VALET

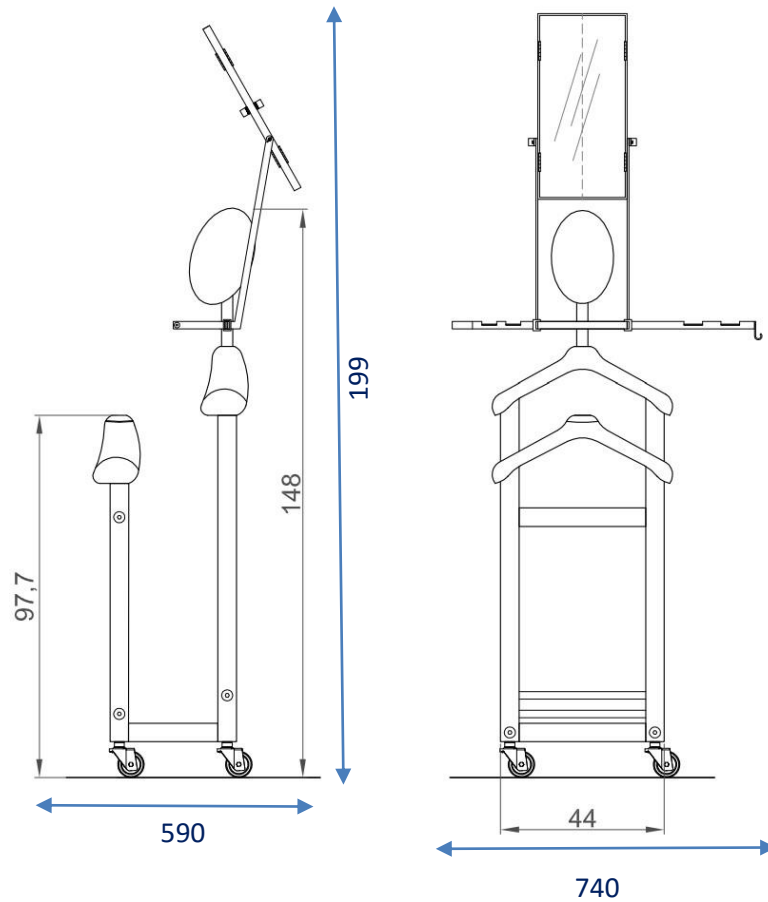

- MEASUREMENTS, IN CM: W 74 X H 199 X D 59
- RECLAIMED ELM WOOD BEAMS
- WOOD HELD TOGETHER WITH TRADITIONAL CHINESE JOINERY
- ECO-FRIENDLY, THIRD PARTY CERTIFIED GLUE
- MIRROR
- WHEELS
- WEIGHT: 17 KG
- PRODUCTION YEAR: 2015

VALET



RECLAIMED ELM WOOD BEAMS

- LOCALLY SOURCED
- NOT SUBMITTED TO CHEMICAL TREATMENTS
- HAND-CARVED
- FINISHED WITH NATURAL BEESWAX



HANDLE WITH LOVE

- THE WOOD MAY DEVELOP CRACKS, DISCOLORATIONS AND/OR OTHERWISE MOVE OR SHIFT. THIS IS PART OF THE WORKS OF NATURE, CANNOT BE AVOIDED AND IS AN INHERENT PART OF THE PRODUCT. PROPER CARE WILL CURTAIL THESE CHANGES

AESTHETIC

CRAFTED

CONSCIOUS