

CODE OPTIONS

CSD-1	STANDARD
-------	----------

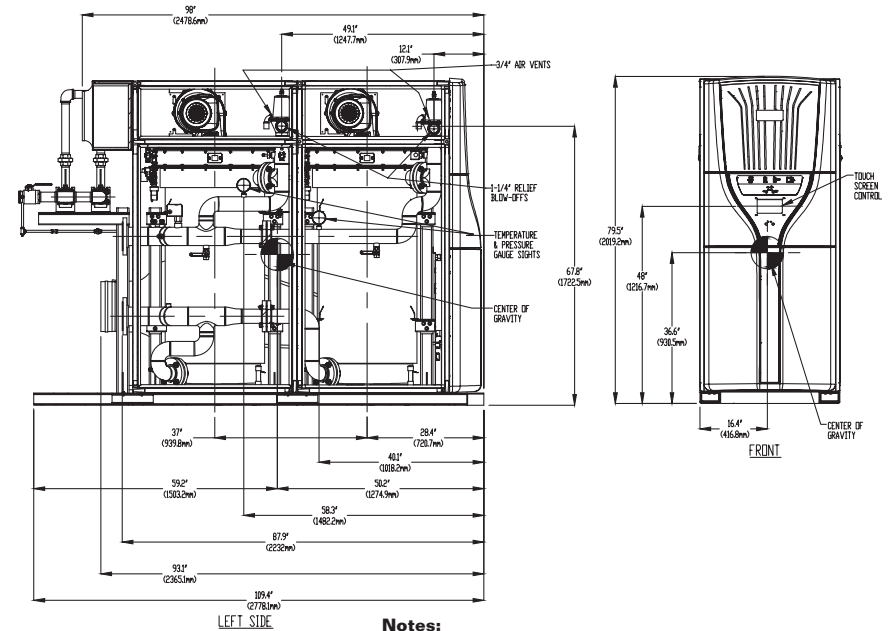
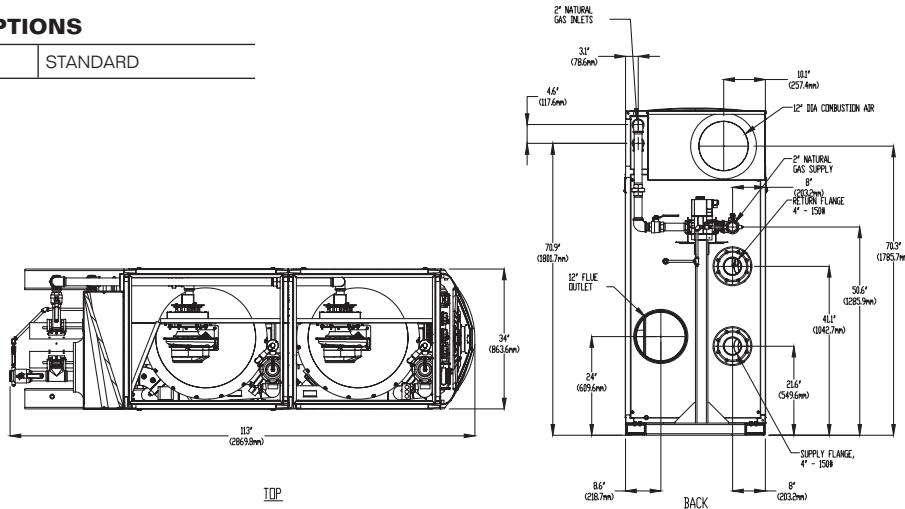

Notes:

1. Dimensions are approximate and should not be used to "rough-in" equipment.
2. Dimensions are subject to change without notice.

BOILER CERTIFIED RATINGS & CAPACITIES

Fuel Type	Natural Gas	Boiler FLA	***
Input BTU/hr.	6,000,000 / 1758 KW	Boiler HP	173.5
Output BTU/hr.	5,808,000 / 1702 KW	Min. Gas Pressure Required	3" W.C.
Electrical Requirements	208/230 VAC 60 hz/3PH (with neutral)	Max. Gas Pressure Allowed	14" W.C.
		Operating Weight	***

BOILER TRIM & CONTROLS

Main Gas Valve	Dungs MBC	Air Switch	Huba
Firing Valve	1 1/2" Apollo	Flow Switch	TACO
Ignition Control	Honeywell RM7895C	Blocked Flue Switch	Cleveland NS2
Operating Control	HeatNet®	Blower Motor	Ametek
High Limit	Honeywell L4006E	L.W.C.O.	750P-MT-120
Main Ball Valve	1 1/2" Apollo	Relief Valve	1-1/2" x 2" set @ 50 psi
Pilot Cock	1/4"	Pilot Regulator	CV100

A.S.M.E.

ASME Sect IV Fire Side Htg Surface	470 Sq. Ft. / 43.6 Sq. M.	Design Data	Max. 160 psig & 210°F
ASME Sect IV Water Side Htg Surface	488 Sq. Ft. / 45.2 Sq. M.	Water Volume	112 gal. / 424 Liters
CV. GPM (1PSID)	***		

* Add circulator amps.

BOILER TEMPERATURE RISE / PRESSURE DROP (Based on Full Input)

20°F / 11.1°C		40°F / 22.2°C		60°F / 33.3°C		80°F / 44.4°C		100°F / 55.5°C							
Flow Rate	Pressure Drop	Flow Rate	Pressure Drop	Flow Rate	Pressure Drop	Flow Rate	Pressure Drop	Flow Rate	Pressure Drop						
GPM	L/s	Ft	kPa	GPM	L/s	Ft	kPa	GPM	L/s	Ft	kPa	GPM	L/s	Ft	kPa
581.0	36.7	***	***	290.5	18.3	***	***	193.7	12.2	***	***	145.3	9.2	***	***

Flow GPM		Temp. Rise** (°F)		Vent Length (Equiv. Ft.)		Air Inlet Length (Equiv. Ft.)	
Min	Max	Min	Max	Min	Max	Min	Max
116.2	581.0	20	100	6	100	0	100

** Min/Max delta t reflects boiler operation at full input. For applications requiring operation above/below these parameters please consult factory.

***Pending

REP FIRM _____
 SUBMITTED BY _____
 JOB NAME _____
 ARCHITECT _____
 ENGINEER _____
 CONTRACTOR _____
 DATE _____

FlexCore 6000

Category II or Category IV Appliance
 (see Installation and Operation Manual for venting information)



A Division of Mestek, Inc.
 Westfield, MA 01085
 (413) 568-9571