

## CODE OPTIONS

CSD-1 STANDARD

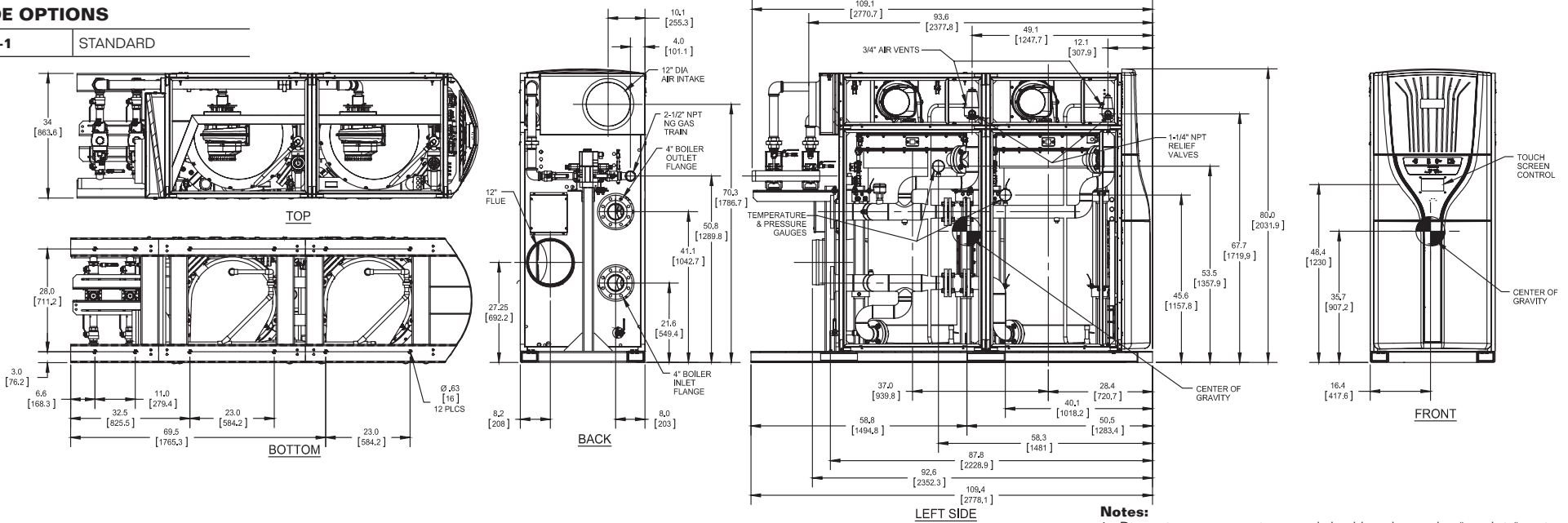

### Notes:

1. Dimensions are approximate and should not be used to "rough-in" equipment.
2. Dimensions are subject to change without notice.
3. All dimensions are in inches (mm).

## BOILER CERTIFIED RATINGS & CAPACITIES

<b>Fuel Type</b>	Natural Gas	<b>Boiler FLA</b>	20.6*
<b>Input BTU/hr.</b>	5,000,000 / 1465 KW	<b>Boiler HP</b>	143.2
<b>Output BTU/hr.</b>	4,795,000 / 1405 KW	<b>Min. Gas Pressure Required</b>	3" W.C.
<b>Electrical Requirements</b>	208/230 VAC/60 hz/3PH (with neutral)	<b>Max. Gas Pressure Allowed</b>	14" W.C.
		<b>Operating Weight</b>	4685 lbs / 2125 kg

## BOILER TRIM & CONTROLS

<b>Main Gas Valve</b>	Dungs MBC	<b>Air Switch</b>	Huba
<b>Firing Valve</b>	1 1/2" Apollo	<b>Flow Switch</b>	ITT FS8W
<b>Ignition Control</b>	Honeywell RM7895C	<b>Blocked Flue Switch</b>	Cleveland NS2
<b>Operating Control</b>	HeatNet®	<b>Blower Motor</b>	Ametek
<b>High Limit</b>	Jumo	<b>L.W.C.O.</b>	800
<b>Main Ball Valve</b>	1 1/2" Apollo	<b>Relief Valve (2)</b>	1-1/4" x 1-1/4" set @ 50 psi
<b>Pilot Cock</b>	1/4"	<b>Pilot Regulator</b>	White-Rodgers

## A.S.M.E.

<b>ASME Sect IV Fire Side Htg Surface</b>	404 Sq. Ft. / 37.6 Sq. M.	<b>Design Data</b>	Max. 160 psig & 210°F
<b>ASME Sect IV Water Side Htg Surface</b>	422 Sq. Ft. / 39.2 Sq. M.	<b>Water Volume</b>	116 gal. / 438 Liters
<b>CV. GPM (1PSID)</b>	166		

\* Add circulator amps.

## BOILER TEMPERATURE RISE / PRESSURE DROP (Based on Full Input)

20°F / 11.1°C		40°F / 22.2°C		60°F / 33.3°C		80°F / 44.4°C		100°F / 55.5°C											
Flow Rate	Pressure Drop	Flow Rate	Pressure Drop	Flow Rate	Pressure Drop	Flow Rate	Pressure Drop	Flow Rate	Pressure Drop										
GPM	L/s	Ft	kPa	GPM	L/s	Ft	kPa	GPM	L/s	Ft	kPa	GPM	L/s	Ft	kPa				
479.7	30.3	19.3	57.6	239.8	15.1	4.8	14.4	159.9	10.1	2.1	6.4	119.9	7.6	1.2	3.6	95.9	6.1	0.8	2.3

Flow GPM		Temp. Rise** (°F)		Vent Length (Equiv. Ft.)		Air Inlet Length (Equiv. Ft.)	
Min	Max	Min	Max	Min	Max	Min	Max
95.9	479.7	20	100	6	100	0	100

\*\* Min/Max delta t reflects boiler operation at full input. For applications requiring operation above/below these parameters please consult factory.

REP FIRM \_\_\_\_\_  
 SUBMITTED BY \_\_\_\_\_  
 JOB NAME \_\_\_\_\_  
 ARCHITECT \_\_\_\_\_  
 ENGINEER \_\_\_\_\_  
 CONTRACTOR \_\_\_\_\_  
 DATE \_\_\_\_\_

# FlexCore 5000

**Category II or Category IV Appliance**  
 (see Installation and Operation Manual for venting information)



A Division of Mestek, Inc.  
 Westfield, MA 01085  
 (413) 568-9571