

BULK LIQUID SYSTEMS

Shick USA's Bulk Liquid Handling systems are available for nearly every liquid bulk handling need.

These systems are available with truck or railcar unloading, modified head space environment with nitrogen or UV filtration, in single or multi-tank systems. Options include Clean-In-Place capabilities, heating or cooling, and multiple tank configurations. Shick's Bulk Liquid Handling Systems are a combination of practical flexibility and standardization to provide a cost effective and efficient system.

CONTROLS

Controls for automatic valving and pump regulation can be added to the system for complete automation. Features include local or remote control, automated supply valves, temperature control, water jacketed or heat traced piping, PLC or basic functionality, recipe integration, and lot tracking.



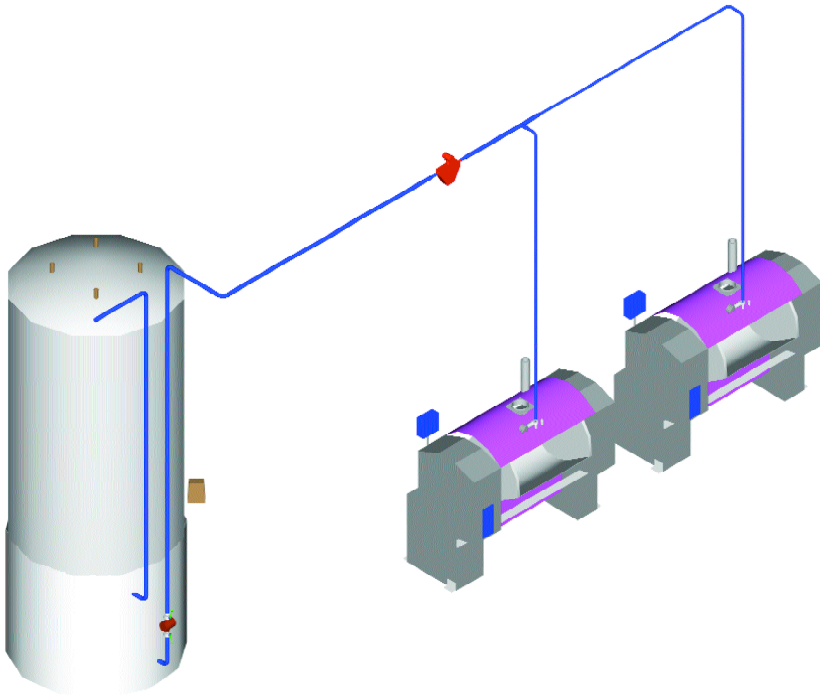

Bulk System demo

RFO DATA

- Product _____
- Batch Size (Minimum and Maximum)

- Batches/Hr _____
- Time to Deliver _____
- Distance from tank location to usepoint
(Maximum) _____
- Required Storage Temperature _____

STANDARD EQUIPMENT

- Standard tanks available in 6, 8, 10, & 12,000 gallon capacity. Other sizes also available.
- Standard tank construction of Carbon Steel, Carbon Steel with food grade lining, or
- Piping systems provided in sanitary stainless steel tubing with Tri-Clamp connections.
- Pumps and valves specified particularly for process requirements.
- State of the art mass flow meters for precise and accurate metering.

HEADQUARTERS:

ShickUSA
4346 Clary Blvd.
Kansas City, Mo 64130
Tel: (816) 861-7224 / Fax: (816) 921-1901

ShickAP
Blk 5000 Ang Mo Kio Ave 5
#05-07 Techplace II
Singapore 569870
Tel: (65) 64824600 / Fax: (65) 64818255
www.shickusa.com

Information on this page is subject to change without notice. For additional information on this and other Shick Tube-Veyor products and services, please call Shick directly or your local representative.

REPRESENTED BY:

