

# 2160(F)

## Concealed Vertical Rod Exit Devices

**ACCENTRA**  
**ASSA ABLOY**

### Installation Instructions

**2160 (Panic Label)**  
**2160F (Fire Label)**

Packed for reinforced metal doors.

Optional sex nuts required for unreinforced metal doors or composite wood doors and are furnished standard with all fire rated (F) devices.

**Outside Trim:** Device is packed ready for any applicable ASSA ABLOY ACCENTRA™ Trim.

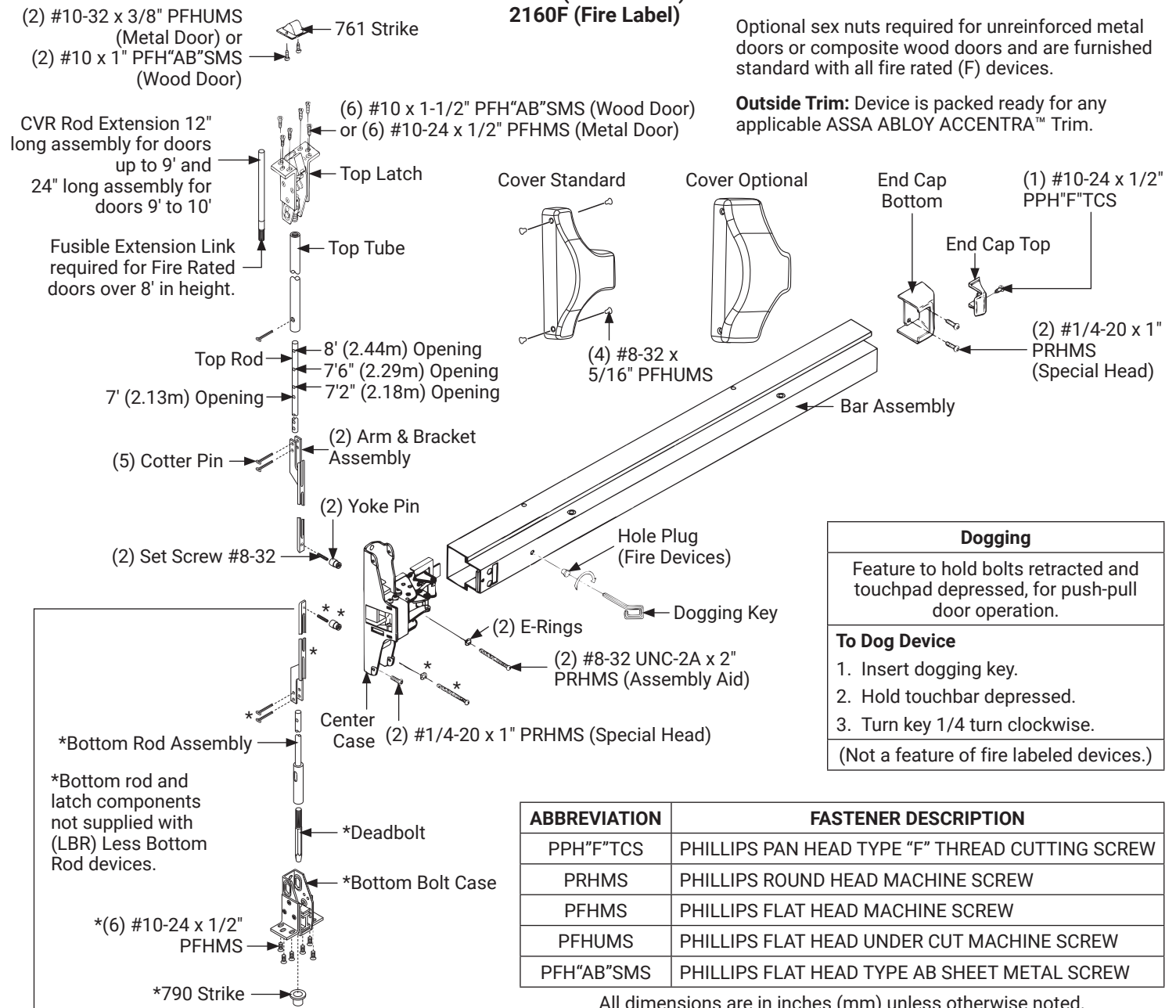

### WARNING

This product can expose you to lead which is known to the state of California to cause cancer and birth defects or other reproductive harm. For more information go to [www.P65warnings.ca.gov](http://www.P65warnings.ca.gov).

### WARNING

Attention Installer: Any retrofit or other field modification to a fire rated opening can potentially impact the fire rating of the opening, and ASSA ABLOY makes no representations or warranties concerning what such impact may be in any specific situation. When retrofitting any portion of an existing fire-rated opening, or specifying and installing a new fire-rated opening, please consult with a code specialist or local code official (Authority Having Jurisdiction) to ensure compliance with all applicable codes and ratings.

80-9470-2160-000 04/24

1-855-557-5078 Ext. 2 • [www.accentra-assaabloy.com](http://www.accentra-assaabloy.com)

Copyright © 2019, 2023, 2024, ASSA ABLOY ACCENTRA™ Access and Egress Hardware Group, Inc. All rights reserved. Reproduction in whole or in part without the express written permission of ASSA ABLOY Access and Egress Hardware Group, Inc. is prohibited.

Experience a safer  
and more open world

### To Change Hands

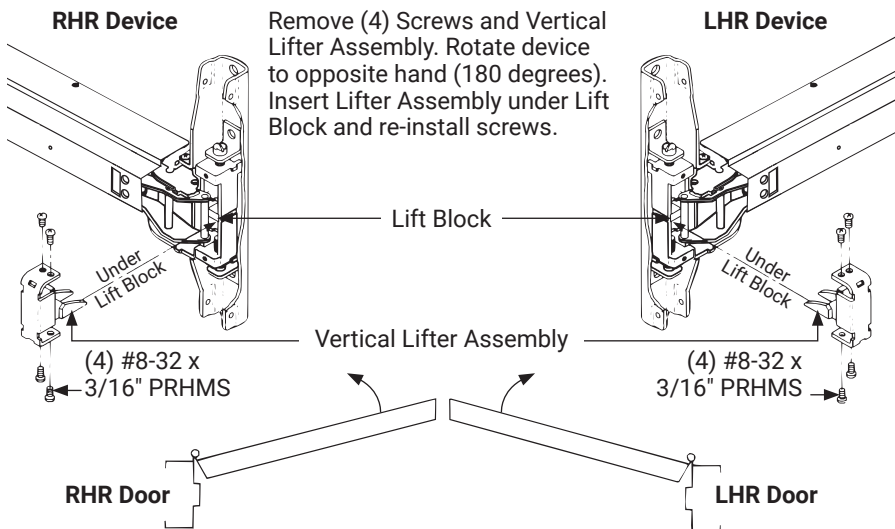

### Maintenance

1. Periodically remove covers and coat mechanisms with a silicone base lubricant. This is particularly required in corrosive environments for proper product function.
2. Check mounting fasteners periodically. Retighten if found loose. Apply screw locking compound (available at automotive part stores) or change part fasteners if screws continue to back up.
3. Periodic checks (and adjustments) of rods are required to compensate for changes in the opening (e.g. door sagging).

### Check Before Starting Unreinforced Doors or Frames

Doors and Frames with walls having a structural thickness (metal skin plus reinforcement or solid hardwood) to engage less than (3) full screw threads are considered unreinforced.

Unreinforced Doors: Use SNB (sex nuts and bolts) or Blind Rivet Nuts.

Unreinforced Frames: Use Blind Rivet Nuts.

Recommended fasteners for unreinforced openings are not necessarily supplied by ACCENTRA.

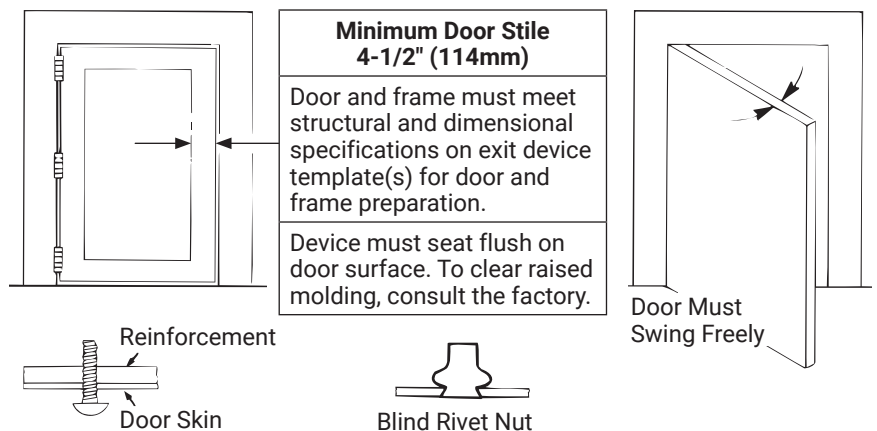

### 1. Mark Door

#### Locate and Mark Horizontal and Vertical Reference Centerlines as shown.

LHR door shown. Preparation is typical for both door hands.

**NOTE:** Bottom Bolt will retract to 1/8" (3mm) above Floor Strike. Floor covering in the door path must be laid out accordingly.

LBR - For less bottom rod devices, omit bottom latch and strike installation steps and see separate instructions for the top latch and strike.

**NOTE:** Less Bottom Rod (LBR) Devices should not be used where security is primary concern.

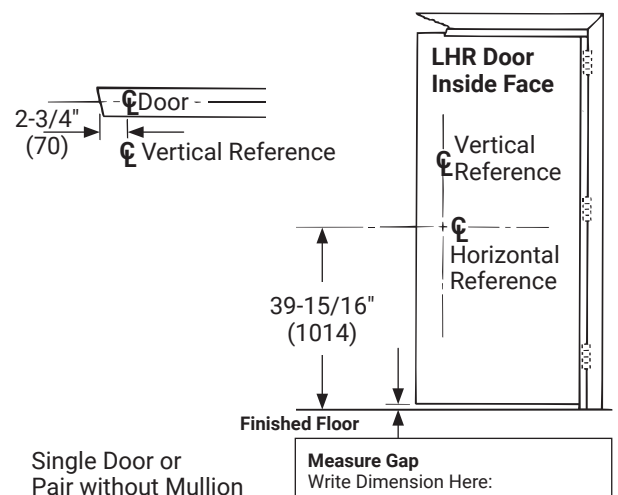

# 2160(F)

## Concealed Vertical Rod Exit Devices Installation Instructions

ACCENTRA

ASSA ABLOY

### 2. Prepare Door, Frame & Sill

1. Seat plastic template on door and stop faces.
2. Extend centerline of Rods and Strikes from "Device Template" to door top and bottom, on door face.
3. Locate "Top Strike" and "Floor Strike" templates, aligned on centerline of Rods and Strikes on door. Tape templates in place.  
**NOTE:** An auxiliary door marker is included to verify correct door preparation. Reinforced doors and frames, with factory made cutouts, are recommended.

4. Spot and prepare holes:  
**Device Latch Assembly:** Each (2) #1/4-20 Machine Screws\* OR (2) #3/8" (10) Dia. Sex Nuts & Bolts.  
(\* ) Metal reinforced door only.  
(\*\* ) Wood Door Applications  
**Top Strike:** (2) 10-32 machine screws;  
**Bottom Strike:** 5/8" (16) dia. X 3/4" (19) deep hole.

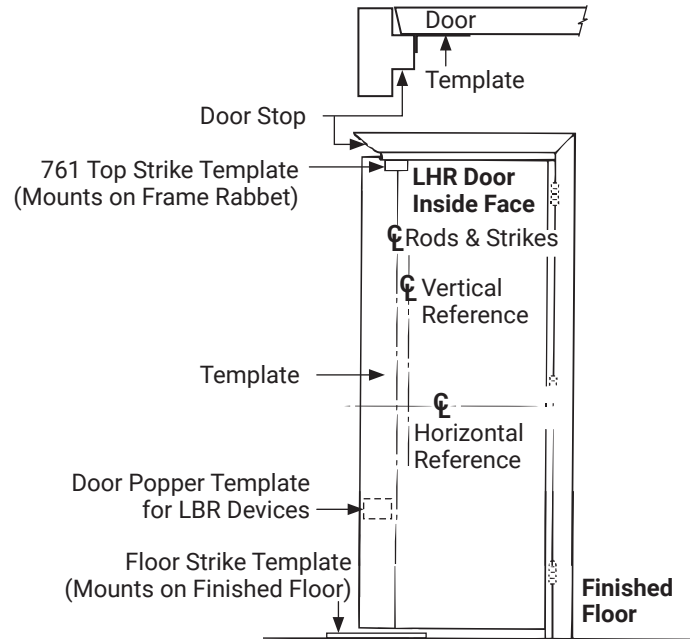
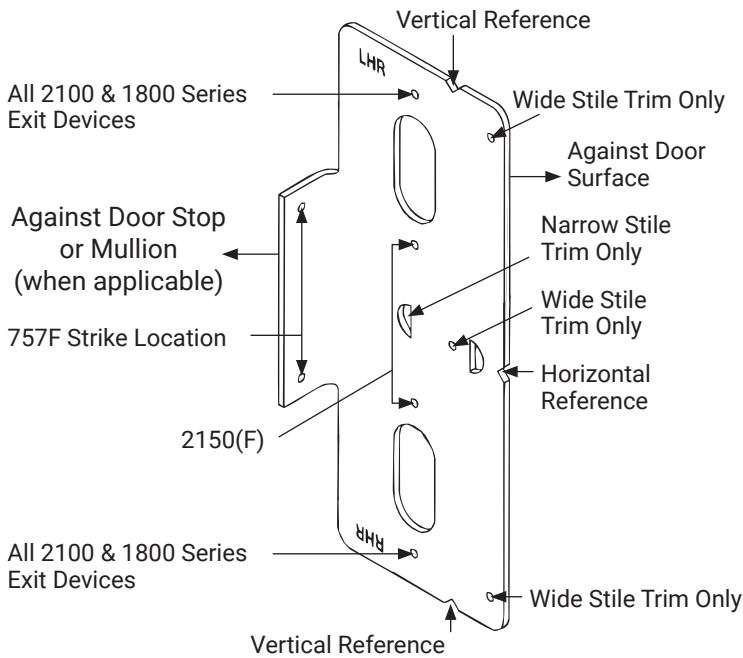

### 3. Size Device

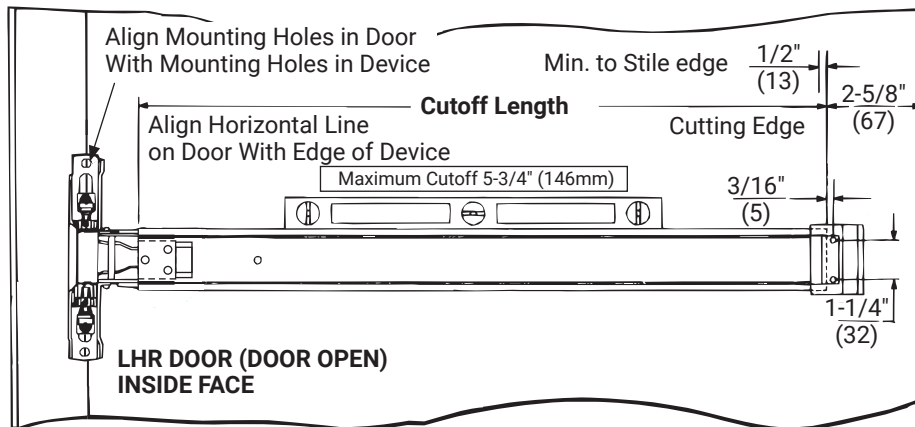

HINGE EDGE OF DOOR

Device must be field cut to size, unless standard opening and device are 36" (0.91m).

### 4. Rod Assembly & Preliminary Adjustment

1. Remove door from opening. Set flat, device side up. (Do not hang door until Step 8 of device installation sheet).
2. Slide Top Tube over Top Rod and attach with one cotter pin (For predrilled hole locations in Top Rod Assembly, See **Detail 1**).  
For doors between 8' and 9' a 12" rod extension assembly must be threaded into the top tube. For doors between 9' and 10' a 24" rod extension assembly must be threaded into the top tube.
3. Connect Top and Bottom Rods to Arm/Bracket Assemblies (2 cotter pins each).
4. Align Rod Setup Gauge over device Cutouts and Centerlines. Tape Gauge to door face.
5. Connect Top Latch to Rod Assembly.
6. Set Upper Latch and Rod Assembly in place on the door surface (1/8" below upper edge of door). Latch bolt must be extended (See **Detail 2**).
7. Align Yoke Pin holes in Arm and Bracket Assembly with Alignment Hole in Rod Setup Gauge. Adjust Top Latch and Rod Assembly for proper alignment. Latchbolt must be extended. (See **Detail 2**).
8. Thread Bottom Bolt into Bottom Rod Assembly. Set Bottom Bolt Rod Assembly in place on door. Align Yoke Pin Hole in the Bottom Arm and Bracket Assembly with Alignment Hole in Rod Setup Gauge. Adjust Bottom Bolt until it protrudes 3/8" (10) + the gap from Step 1, past the bottom edge of door. Make sure the Bottom Bolt is fully extended (See **Detail 3**).

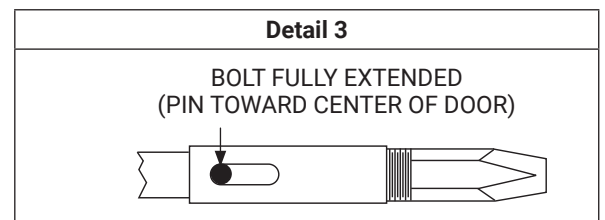
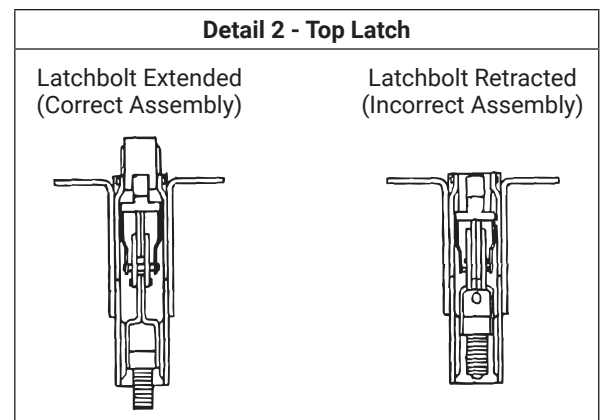
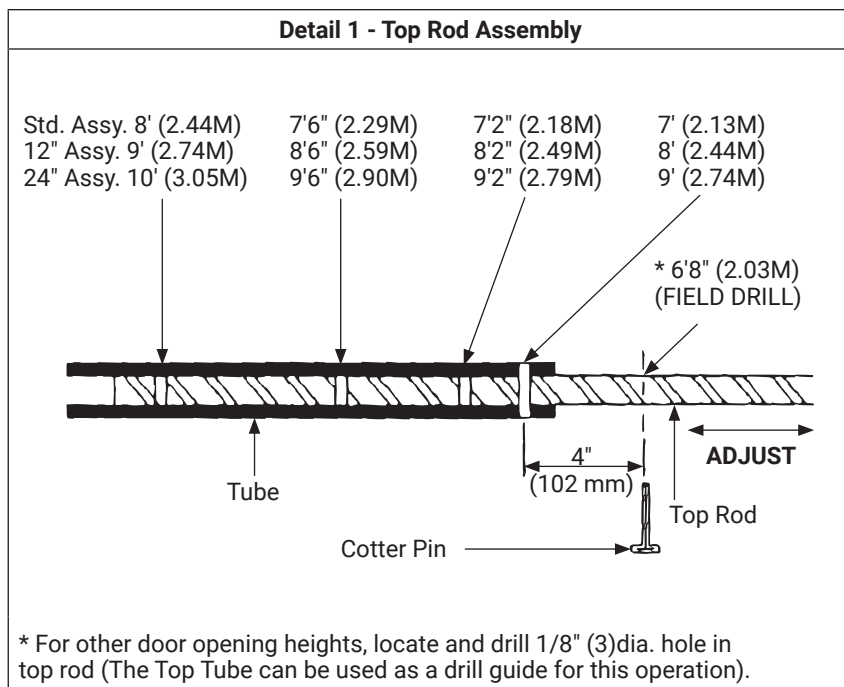
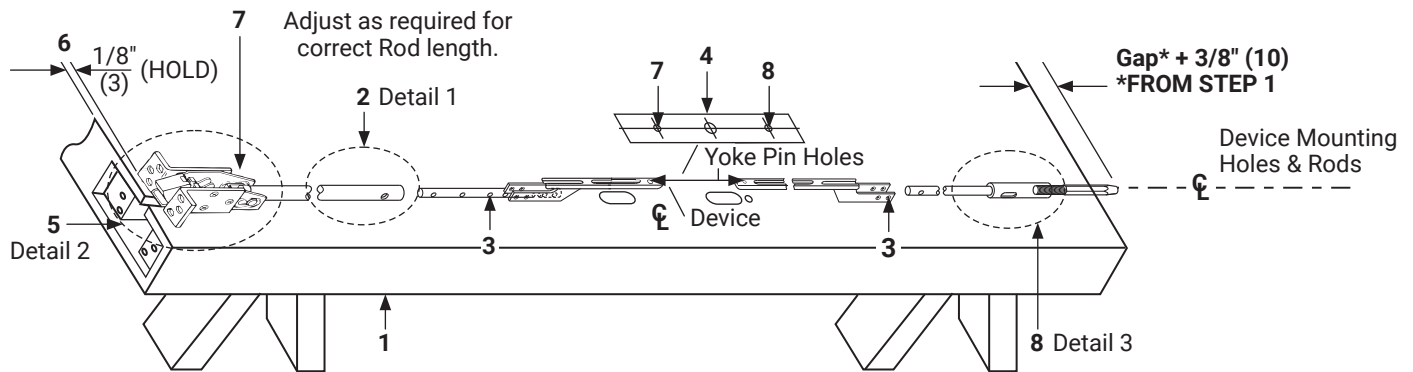

80-9470-2160-000 04/24

Experience a safer  
and more open world

1-855-557-5078 Ext. 2 • www.accentra-assaabloy.com

Copyright © 2019, 2023, 2024, ASSA ABLOY ACCENTRA™ Access and Egress Hardware Group, Inc. All rights reserved. Reproduction in whole or in part without the express written permission of ASSA ABLOY Access and Egress Hardware Group, Inc. is prohibited.

# 2160(F)

## Concealed Vertical Rod Exit Devices Installation Instructions

# ACCENTRA

# ASSA ABLOY

### 5. Install Rods

1. Slide Rod Assemblies into door.
2. Attach Top Latch and Bottom Bolt Case with (12) #10- 24 X 1/2" PFHMS.
3. Thread Set Screw into Yoke Pins (Insert With Hex Socket End Inside Pin). Thread #8-32 X 2" PRHMS Screws into slotted end of Yoke Pins, until seated to Hex Head Set Screw. (See **Detail 1.**)
4. Install (2) Yoke Pin Assemblies into Arm and Bracket Assemblies.

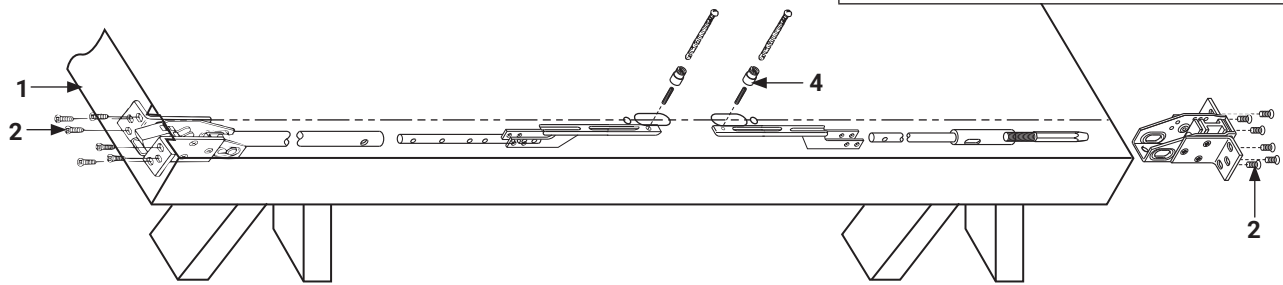
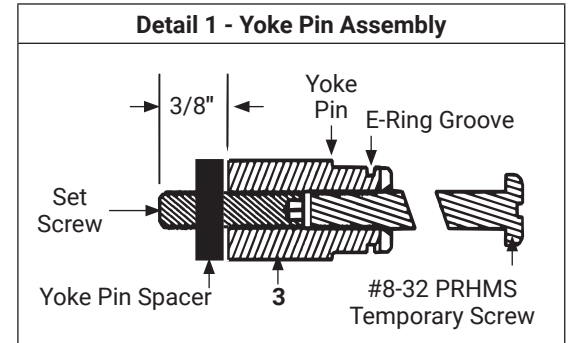

### 6. Install Device

1. Mount trim when required per installation instruction sheet provided with trim pack.
2. Seat device in place using the Temporary Screws from Step 5 to position the Yoke Pins to the latch head. Install E-Ring into Yoke Pin Grooves. (See **Detail 1.**)
3. Fasten device Latch Head (2) #1/4-20 PPHMS or 3/8" (10) dia. SNB.
4. Remove Temporary Screws.  
**NOTE:** Be certain to tighten Yoke Pins after removal of temporary screws.
5. Center end of device on horizontal reference line of door. Using the End Clamp as a template, locate the end clamp mounting holes.
6. Prepare end clamp holes and mount End Clamp using (2) #1/4-20 PRHMS or 3/8" (10) SNB.

**Detail 1**  
(Typical 2 Places)

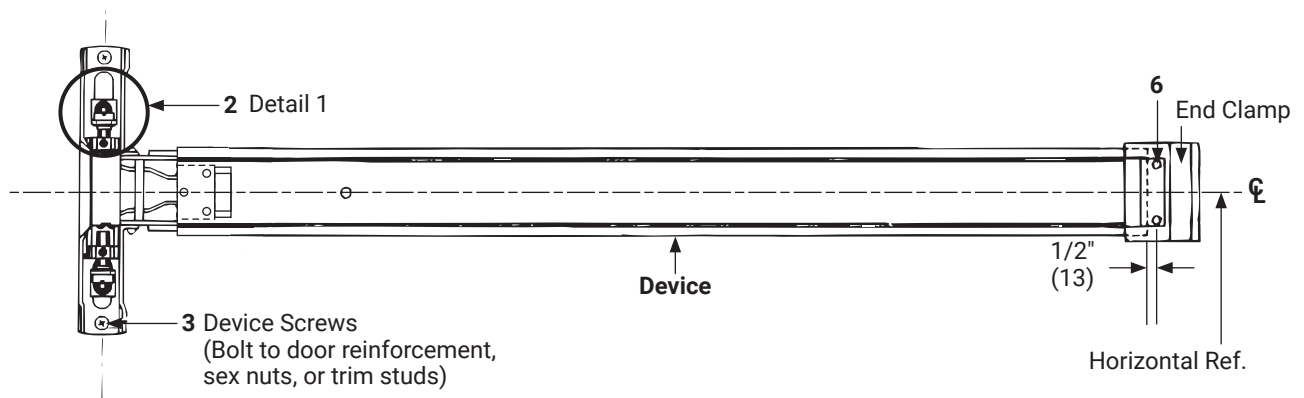
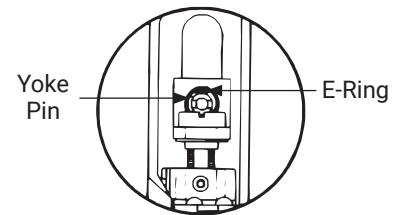

80-9470-2160-000 04/24

1-855-557-5078 Ext. 2 • [www.accentra-assaabloy.com](http://www.accentra-assaabloy.com)

Copyright © 2019, 2023, 2024, ASSA ABLOY ACCENTRA™ Access and Egress Hardware Group, Inc. All rights reserved. Reproduction in whole or in part without the express written permission of ASSA ABLOY Access and Egress Hardware Group, Inc. is prohibited.

Experience a safer  
and more open world

**7. Install Strikes**

**Detail X (Upper Strike)**

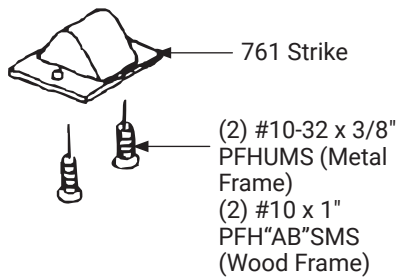

**NOTE:** Pre-drill 5/32"  
 Dia. x 1" Depth.)

**Detail Y (Bottom Strike)**

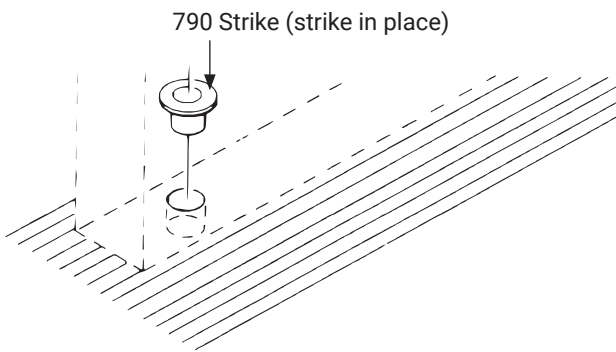

**NOTE:** Bottom Bolt will retract to 1/8" (3mm) above Floor Strike. Floor covering in the door path must be laid out accordingly.

All dimensions are in inches (mm) unless otherwise noted.

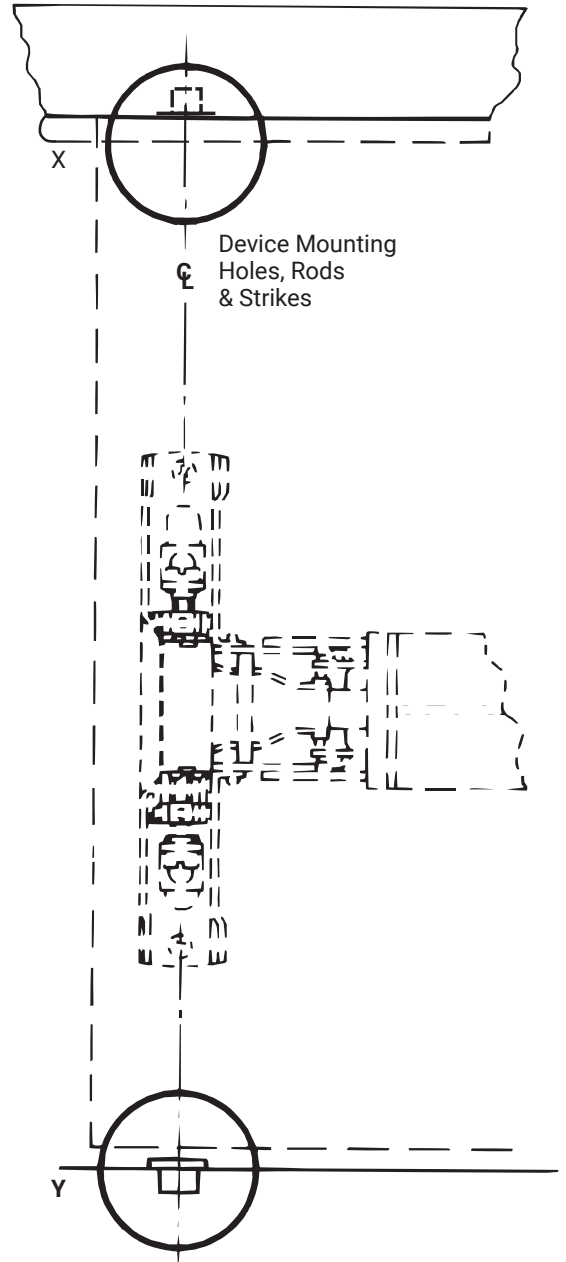

# 2160(F)

## Concealed Vertical Rod Exit Devices Installation Instructions

### 8. Complete Installation

**A.** Rehang the door plumb and true to the opening. Set strike roller between tripping lever and bolt. **DO NOT PRELOAD THE BOLT.** Shim strike as needed.

**NOTE:** Rods should move freely inside door. Bolts extend automatically and should deadlock when door closes and top strike hits tripping lever. Top bolt should retract flat. Bottom bolt should travel 1/2" (13) and engage 3/8" (10) into strike in down position, without dragging on floor surface in up position.

Test device action by touchbar, by trim, and by dogging. Adjust as needed.

#### B. Rod Adjustment for Proper Bolt Throw

1. Use 3/32" hex wrench to loosen set screws B1 and B2.
2. Adjust the top rod first with adjusting screw C1. With device in dogged position (panic devices) or touchbar fully depressed (fire devices) adjust top rod so that the top latchbolt is flush and the hold back feature is engaged. Lengthen top rod an additional 1/2 turn for proper latchbolt positioning.

**NOTE:** If adjusting screws bottom out before proper device operation, door and device must be removed so larger adjustments may be made by threading rod in or out, or by moving cotter pin to different hole in rod (See Installation Instructions Step 4).

3. Adjust bottom rod with adjusting screw C2. With top latch retracted in hold back position, and touchbar dogged or fully depressed, adjust bottom rod so that the deadbolt clears the strike by 1/16" (1.6). The bottom rod should be in position in the active case with the square head of the connector hanging in the Guide. (See note in Step 2 above).
4. Check device operation by opening and closing the door. An additional minor adjustment may be required for full retraction and correct strike engagement.

**NOTE:** To avoid thread damage and provide positive locking, be sure set screws engage flats on adjusting screws.

**C.** After acceptable device function, install third screw in top strike to lock strike in position with #10-24 x 3/4" PFHMS.

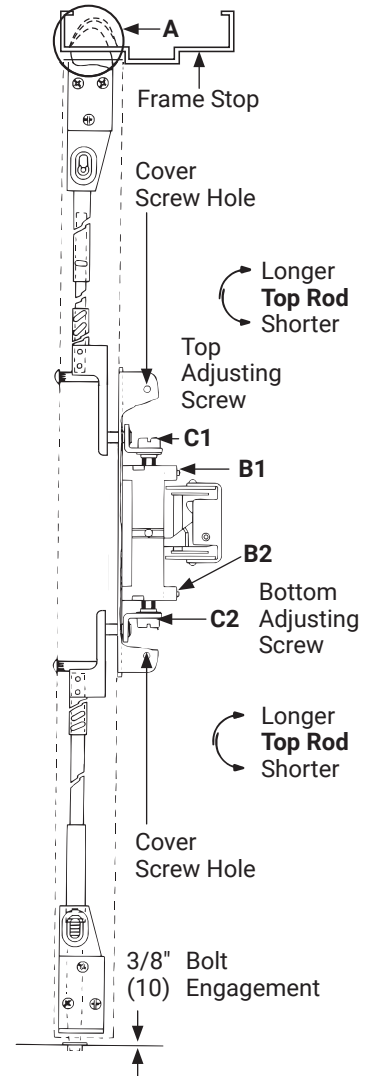

### 9. Install Head Cover & End Cap Top

Cover Detail

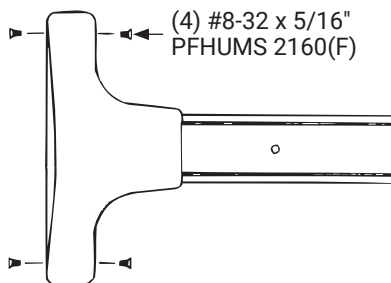

End Cap Detail

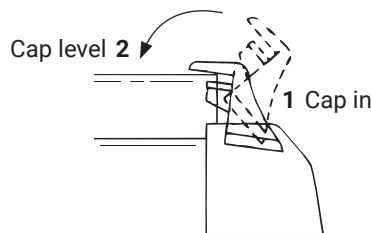

\*(1) #10-24 x 1/2" PPH "F" TCS

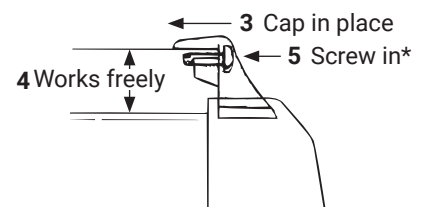

80-9470-2160-000 04/24

1-855-557-5078 Ext. 2 • www.accentra-assaabloy.com

Copyright © 2019, 2023, 2024, ASSA ABLOY ACCENTRA™ Access and Egress Hardware Group, Inc. All rights reserved. Reproduction in whole or in part without the express written permission of ASSA ABLOY Access and Egress Hardware Group, Inc. is prohibited.

Experience a safer  
and more open world

### Instructions:

1. For LBR Devices, omit bottom latch and strike in installation steps.
2. Less Bottom Rod (LBR) Devices should not be used where security is a primary concern.
3. Unreinforced frames, total wall thickness less than 1/8" (3.2), require that 10-24 blind rivet nuts (by others) be used to bolt strike.
4. Dimensions given in inches (mm).
5. **CAUTION:** Office copiers and facsimile machines may change the size of a drawing and make the template inaccurate to use as a door marker. If this is not the original template packed with the device, use only the dimensions written on the template to locate the holes on the door (do not use the template as a door marker).

### AUXILIARY DOOR MARKER (Top & Bottom Latch Mounts)

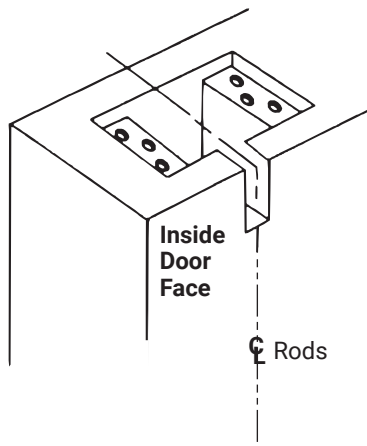
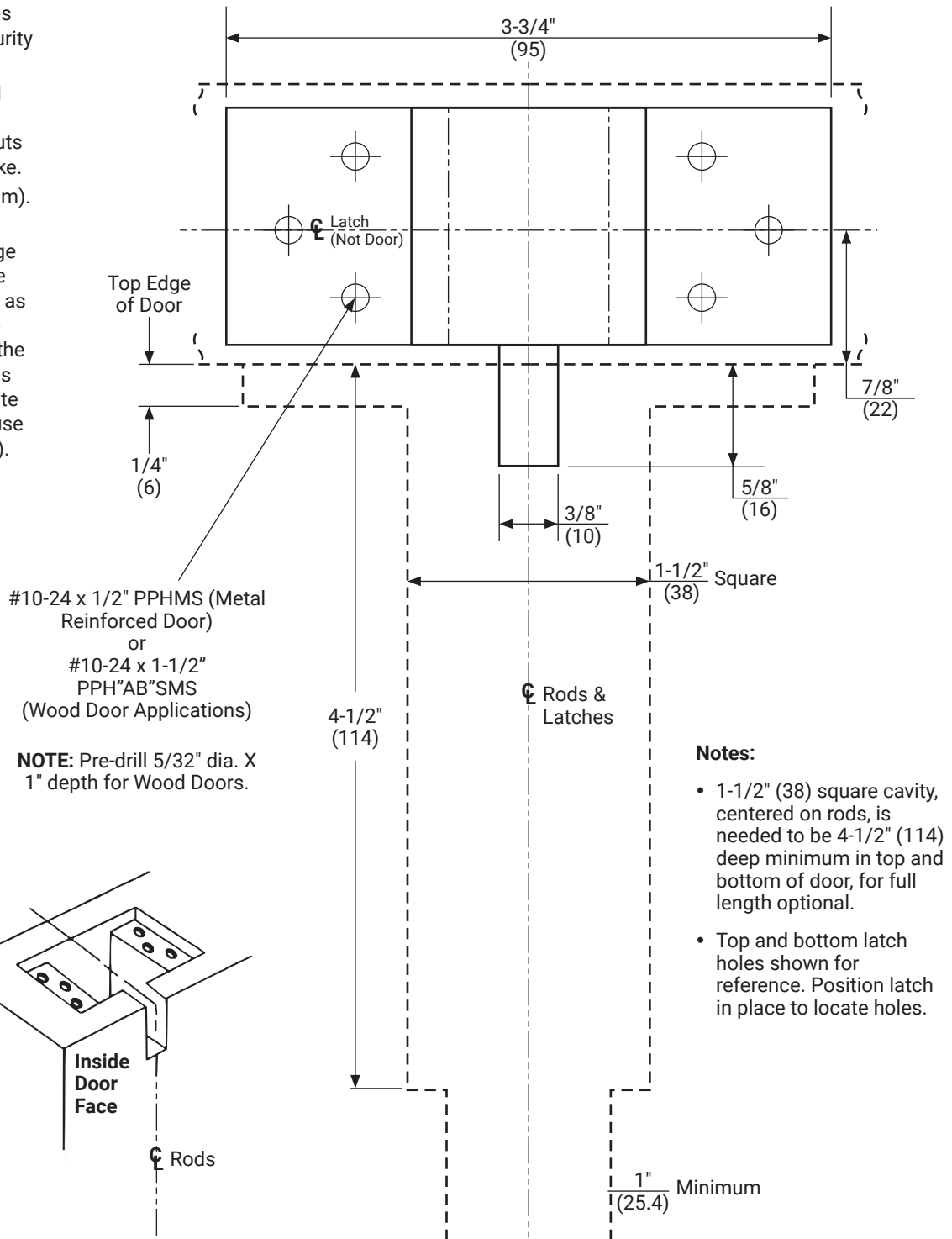



# 2160(F)

## Concealed Vertical Rod Exit Devices Installation Instructions

**ACCENTRA**  

---

**ASSA ABLOY**

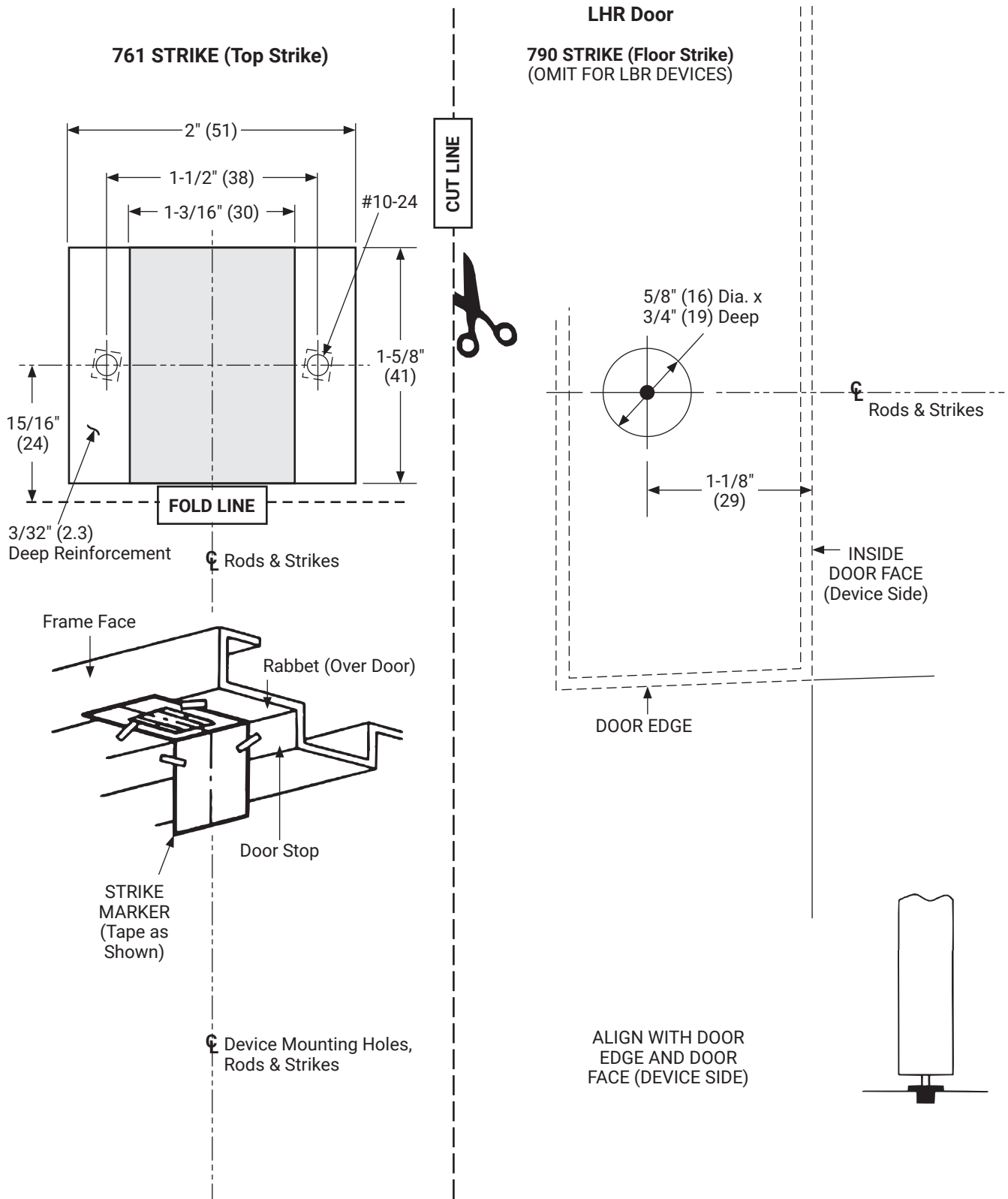

# 2160(F)

## Concealed Vertical Rod Exit Devices Installation Instructions

**ACCENTRA**  

---

**ASSA ABLOY**

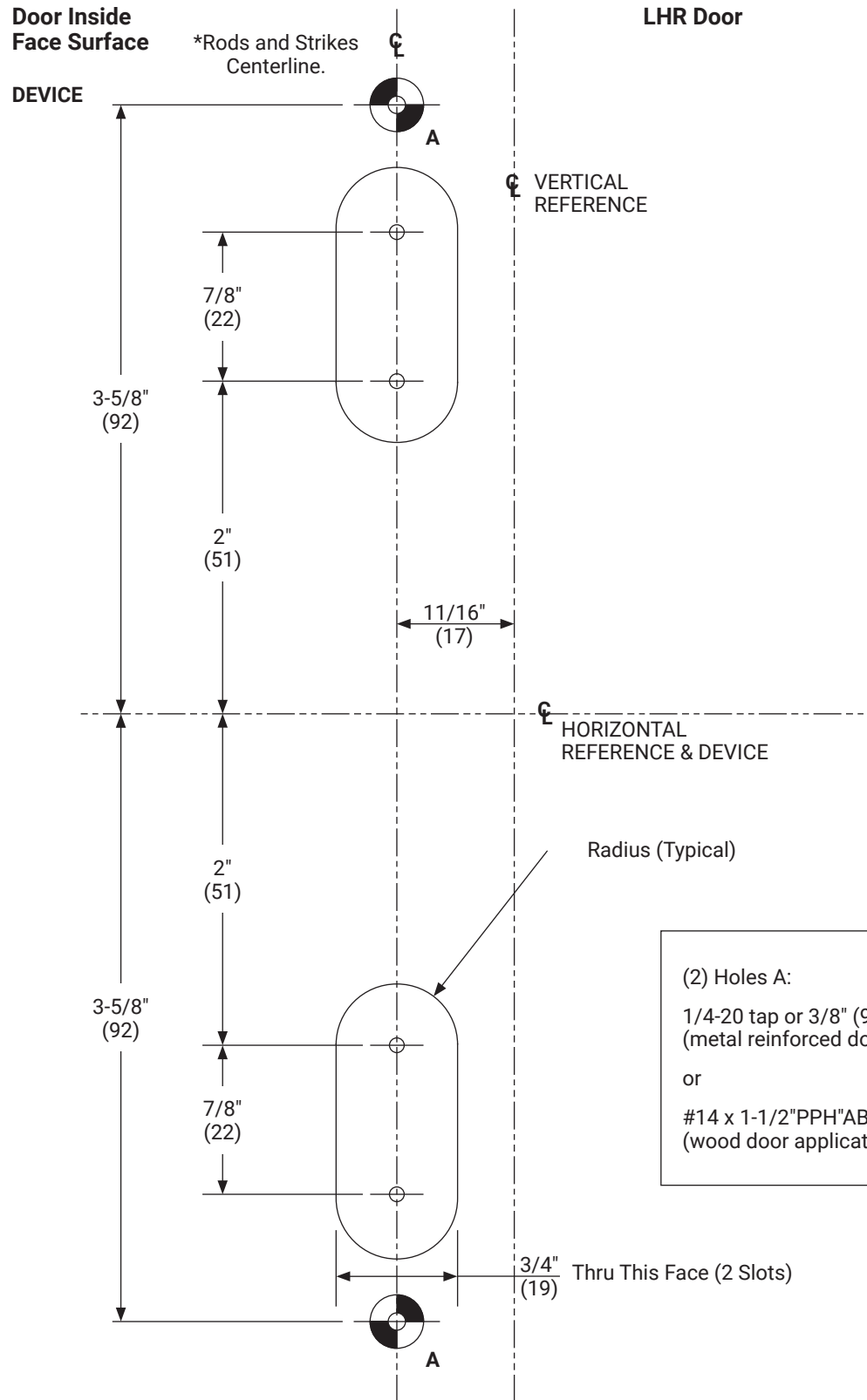

(\*) Mark centerline of Rods on door face.

**NOTE:** The centerline of the rods and strikes, used to install top and bottom bolts, is not the Vertical Reference centerline.

(2) Holes A:  
 1/4-20 tap or 3/8" (9.5) dia. SNB  
 (metal reinforced doors)  
 or  
 #14 x 1-1/2" PPH"AB"SMS  
 (wood door applications).

# 2160(F)

## Concealed Vertical Rod Exit Devices Installation Instructions

**ACCENTRA**  

---

**ASSA ABLOY**

RHR Door

Door Inside  
Face Surface

DEVICE

VERTICAL  
REFERENCE

\*Rods and Strikes  
Centerline.

A

7/8"  
(22)

3-5/8"  
(92)

2"  
(51)

11/16"  
(17)

HORIZONTAL  
REFERENCE & DEVICE

(\* Mark centerline of  
Rods on door face.

**NOTE:** The centerline  
of the rods and strikes,  
used to install top and  
bottom bolts, is not  
the Vertical Reference  
centerline.

Radius (Typical)

2"  
(51)

3-5/8"  
(92)

7/8"  
(22)

Thru This Face (2 Slots)

3/4"  
(19)

A

(2) Holes A:  
1/4-20 tap or 3/8" (9.5) dia. SNB  
(metal reinforced doors)  
or  
#14 x 1-1/2" PPH"AB"SMS  
(wood door applications).

# 2160(F)

## Concealed Vertical Rod Exit Devices Installation Instructions



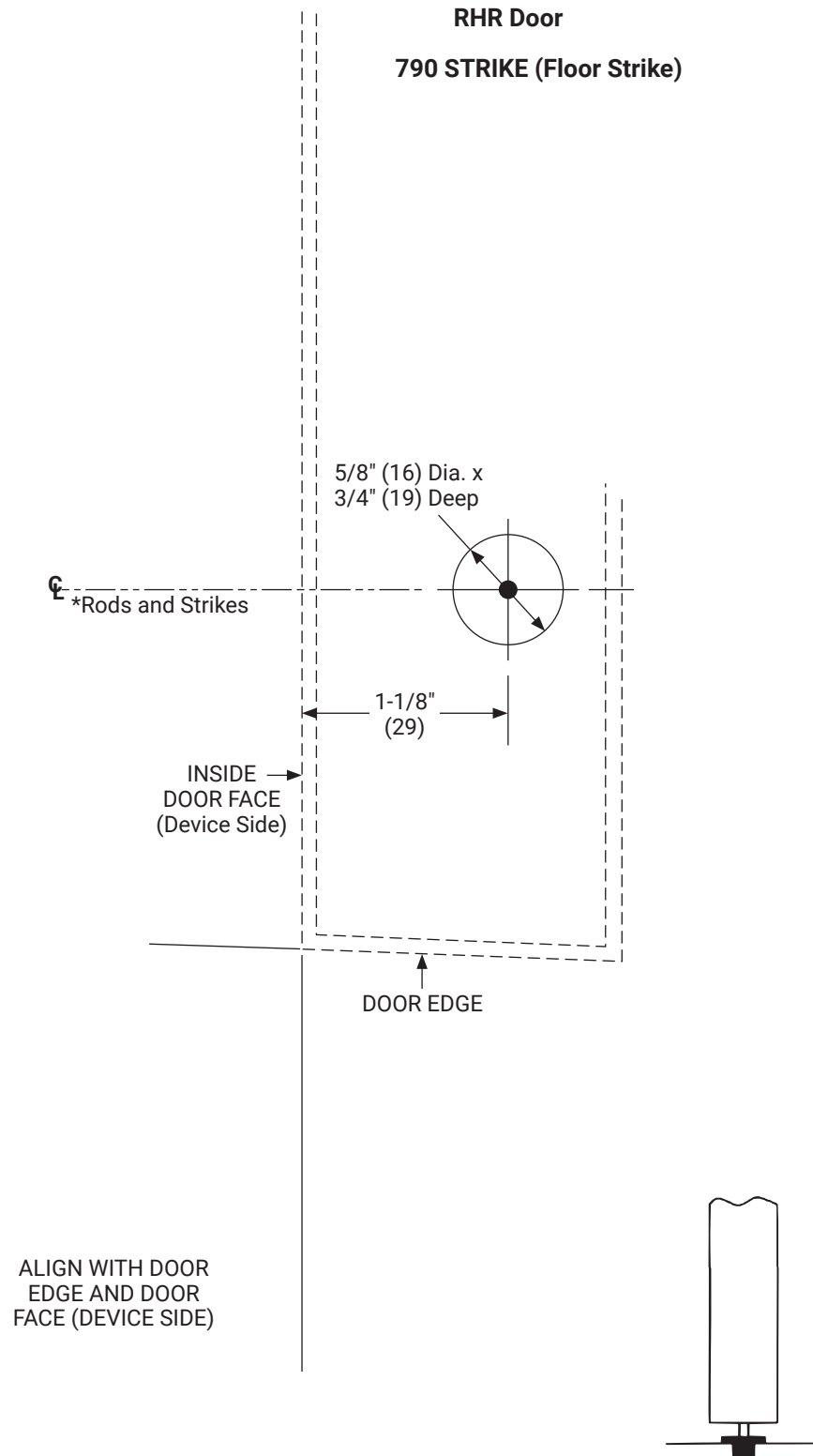



# 2160(F)

## Concealed Vertical Rod Exit Devices Installation Instructions

**ACCENTRA**  

---

**ASSA ABLOY**



# 2160(F)

## Concealed Vertical Rod Exit Devices Installation Instructions

**ACCENTRA**  

---

**ASSA ABLOY**

