

# 6100(F) / 6150 (F) / 6200 / 6250 Series

## Rim & SquareBolt® Exit Devices

### Installation Instructions

ACCENTRA

ASSA ABLOY

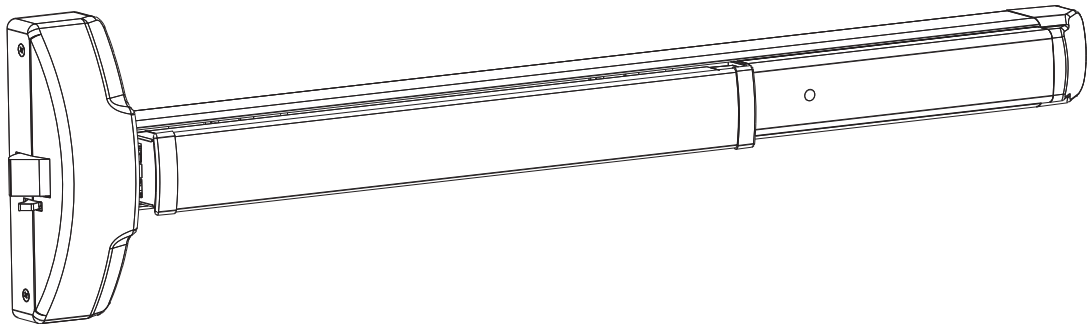
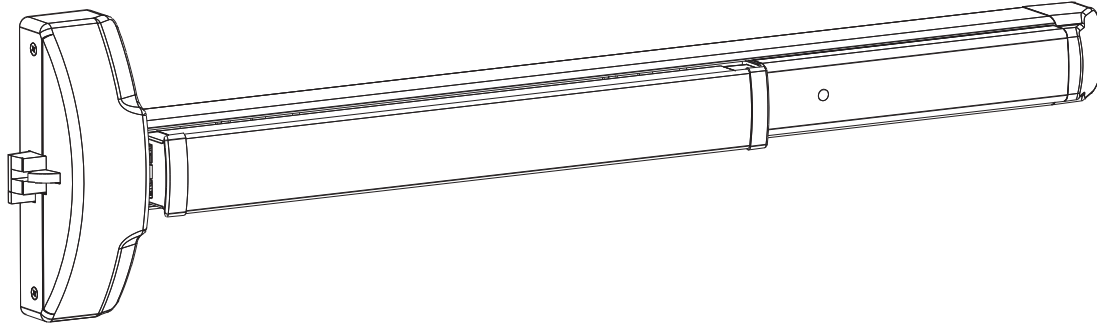

#### NOTE:

To install options, such as shim kits or interlock brackets, refer to the instructions packed with the optional component. Optional hardware is required for unreinforced metal, composite and wood doors. Device is ready for any applicable trim.

#### WARNING

This product can expose you to lead which is known to the state of California to cause cancer and birth defects or other reproductive harm. For more information go to [www.P65warnings.ca.gov](http://www.P65warnings.ca.gov).

#### WARNING

Attention Installer: Any retrofit or other field modification to a fire rated opening can potentially impact the fire rating of the opening, and ASSA ABLOY makes no representations or warranties concerning what such impact may be in any specific situation. When retrofitting any portion of an existing fire-rated opening, or specifying and installing a new fire-rated opening, please consult with a code specialist or local code official (Authority Having Jurisdiction) to ensure compliance with all applicable codes and ratings.

1-855-557-5078 Ext. 2 • [www.accentra-assaabloy.com](http://www.accentra-assaabloy.com)

80-9460-6000-000 04/24

### Verify Parts and Templates

1. Unpack and verify components received using the parts list and exploded view.
2. Read entire instructions before installing this device.

**IMPORTANT:**

- Verify device is being installed on the correct door, as well as function, finish and size.
  - Use site survey to verify correct product ordered.
  - This device is intended to be installed on new 24" (610mm) to 48" (1220mm) metal or wood, pre-drilled, free swinging doors only.
3. Follow all cautions, notes and warnings presented in these instructions.
  4. All dimensions listed are in inches (") and millimeters (mm).

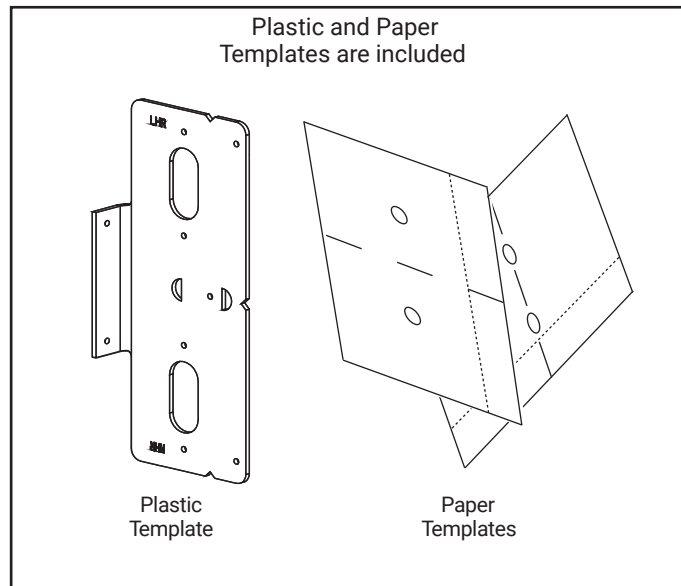

### Tools Required

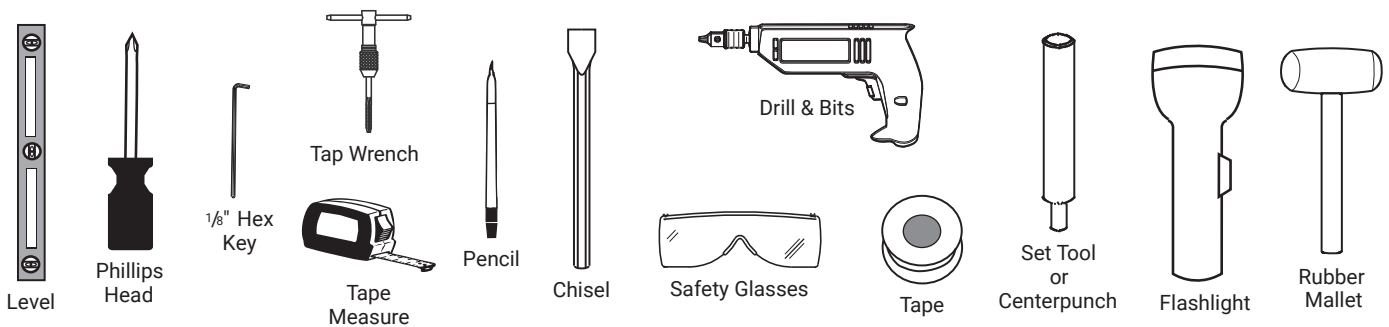

# 6100(F) / 6150 (F) / 6200 /6250 Series

## Rim & SquareBolt® Exit Devices Installation Instructions

# ACCENTRA

# ASSA ABLOY

### Exploded View - 6100(F) / 6150(F) Wide Stile

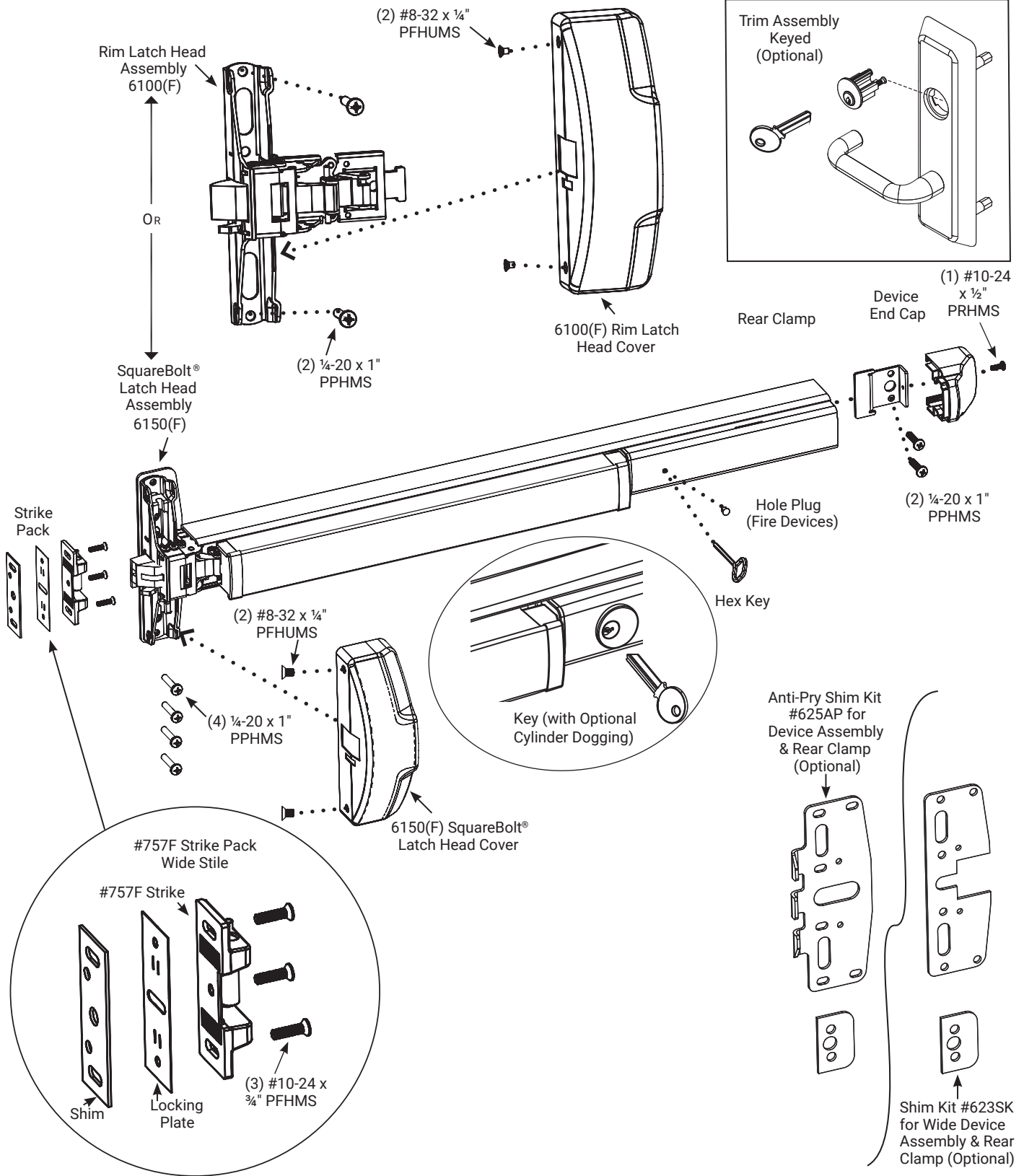

1-855-557-5078 Ext. 2 • www.accentra-assaabloy.com

Copyright © 2015, 2018, 2024, ASSA ABLOY ACCENTRA™ Access and Egress Hardware Group, Inc. All rights reserved. Reproduction in whole or in part without the express written permission of ASSA ABLOY Access and Egress Hardware Group, Inc. is prohibited.

80-9460-6000-000 04/24

Experience a safer  
and more open world

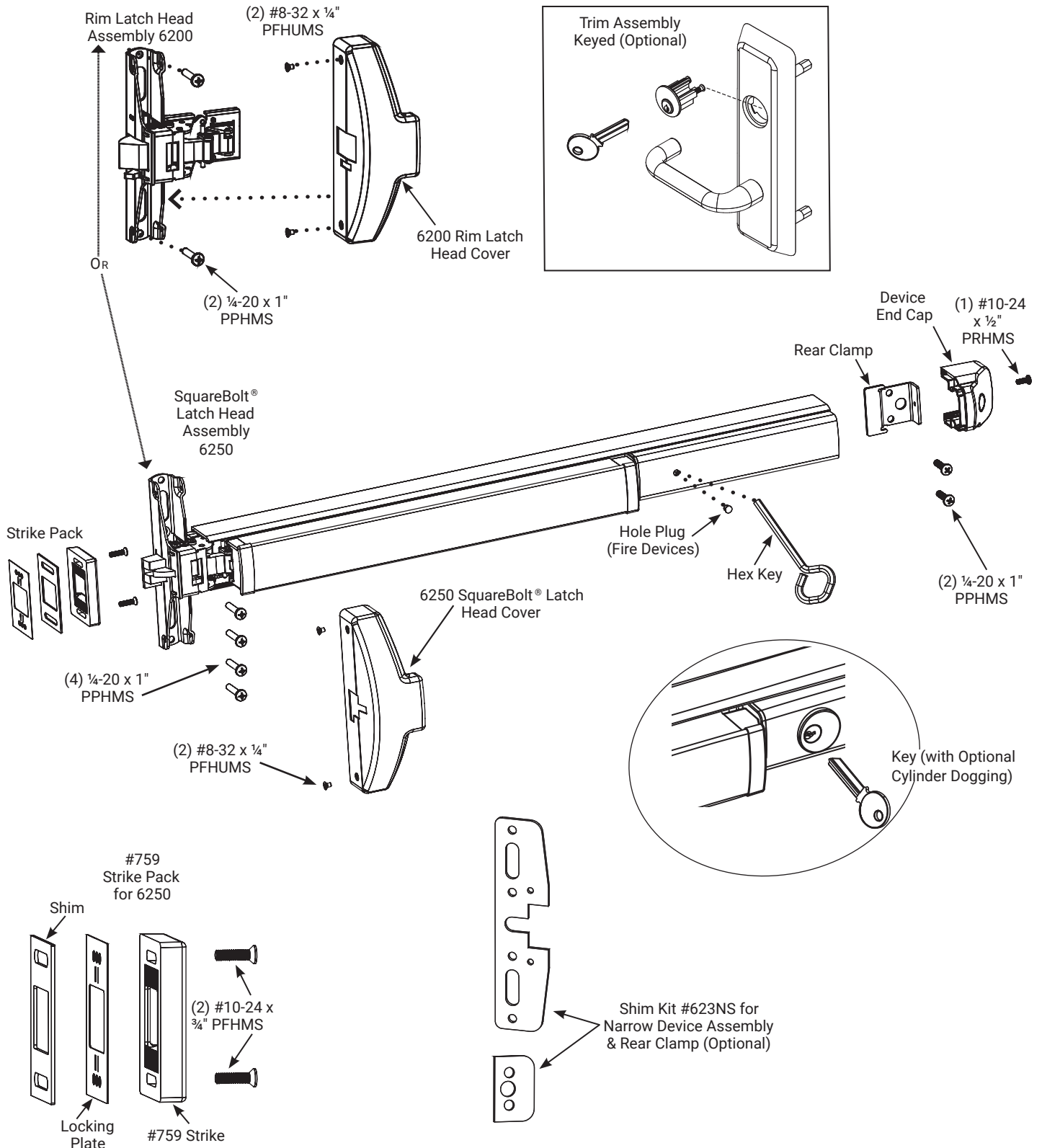

80-9460-6000-000 04/24

Experience a safer  
and more open world

1-855-557-5078 Ext. 2 • [www.accentra-assaabloy.com](http://www.accentra-assaabloy.com)

Copyright © 2015, 2018, 2024, ASSA ABLOY ACCENTRA™ Access and Egress Hardware Group, Inc. All rights reserved. Reproduction in whole or in part without the express written permission of ASSA ABLOY Access and Egress Hardware Group, Inc. is prohibited.

# 6100(F) / 6150 (F) / 6200 /6250 Series

## Rim & SquareBolt® Exit Devices

### Installation Instructions

# ACCENTRA

# ASSA ABLOY

#### Before Installation

1. Make sure the door is plumb and level. Check that the hinges are secure and not missing hardware (Figure 1).
2. If surface of the door is free of raised projections, device may be installed without a shim kit. One (1) shim kit is needed for each 1/4" of projection:
  - 6100(F)/6150(F) – #623SK
  - 6200/6250 – #623NS
3. Fully open the doors to ensure doors do not hit floor as they swing.
4. Determine if door is reinforced. Doors and frame thickness must have three (3) full screw threads to be considered reinforced.

**⚠ Caution:** For Narrow Stile Devices, determine the following opening requirements:

- For aluminum single openings the stop must be notched to clear the strike. The cutout is 3-1/8" (79.4mm) long centered on the device centerline.
- For door pairs with M300 mullions, the strike is machined into the mullion. Position the device carefully, cut off and discard the strike portion of the installation template.
- For all other door openings, the door stile should exceed 3-1/8" (79.4mm) Pair or 2-5/8" (67mm) Single (does not include glass stop) by height of the frame stop, or half the width of the mullion.

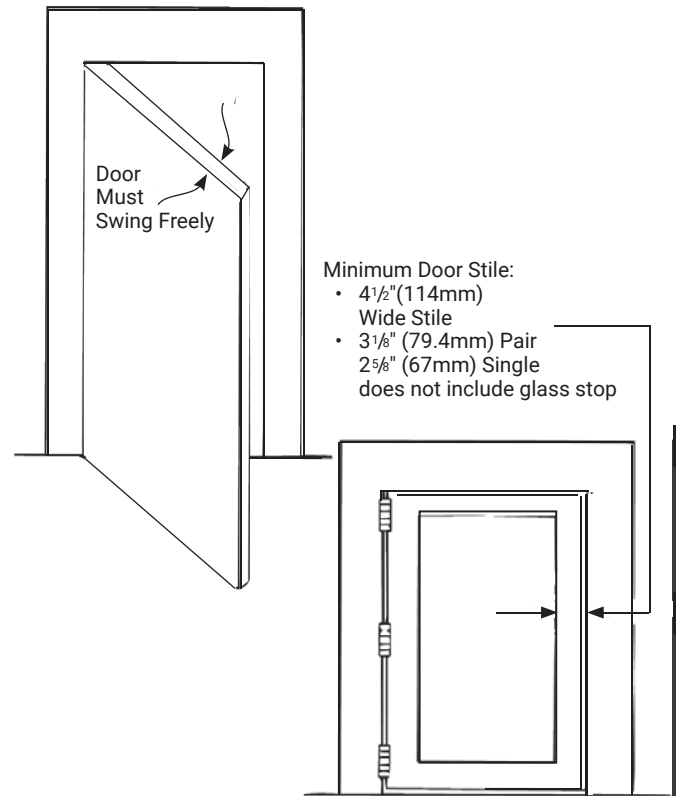

Figure 1: Installation Check

#### Door Reference Lines

1. With door closed, locate and mark horizontal centerline & vertical centerline as shown in Figure 2.
2. Use template included with device for reference.

**⚠ Caution:**

- Standard rail centerline height is 39 15/16" (1015mm) above the finished floor.
- For door pair without mullion, follow the instructions packed with the 793 Strike.

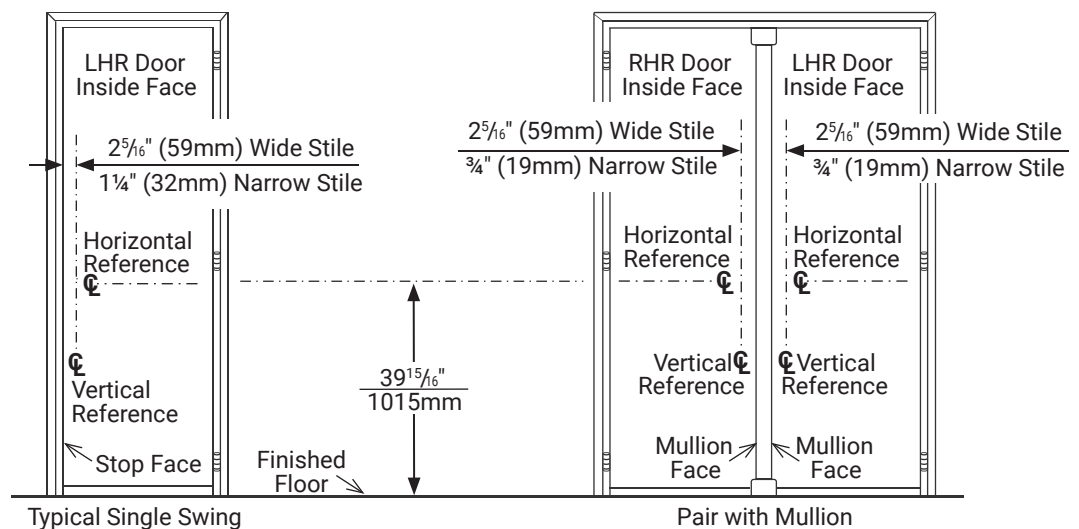

Figure 2: Sample Door Layouts

### ASSA ABLOY

#### Prepare Door & Frame with Templates

**NOTES:** • If factory prepared cutouts with field drilled mounting holes are in the door, skip to: Section G Sizing Exit Device.

• If the door and frame need to be prepared in the field, continue with Section F instructions.

Install the template with the door closed, spot and prepare the mounting holes as follows (Figure 3-A):

1. Mark the device centerline as follows:

a. For Wide Stile

- Locate the vertical reference centerline.
- Measure 11/16" (17.5mm) toward the edge of the door to be sure the plastic template notches properly align with the reference lines.

b. For Narrow Stile

- Use the vertical reference centerline.

2. Use plastic template for wide stile and paper template for narrow stile.

3. Position the template on door and frame.

4. Align the template with the vertical reference line.

5. Tape the template to the door face and frame. Be sure the template is opposite the door hinges.

6. Mark the door and frame per template, as shown in Figure 3-A. Drill and tap only those holes needed for the device/trim being installed.

7. If trim is used, locate templates packed with trim, position templates and mark holes per trim instructions.

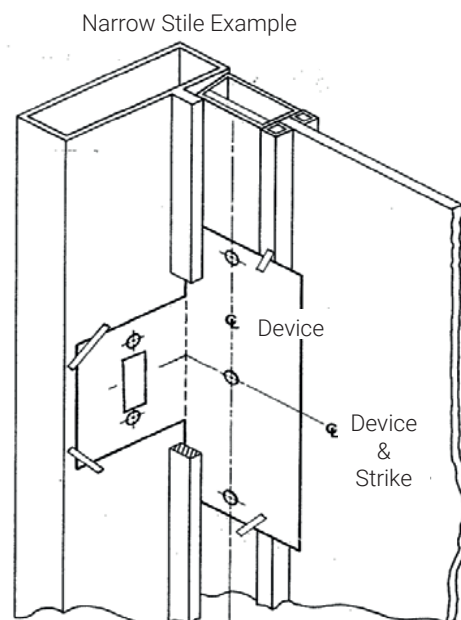
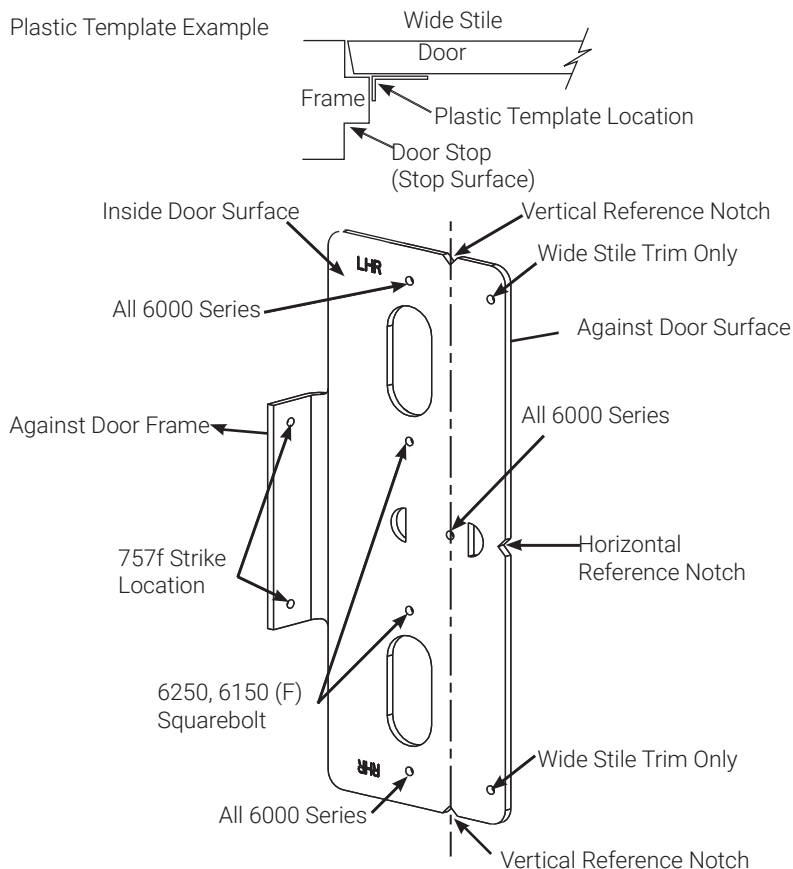
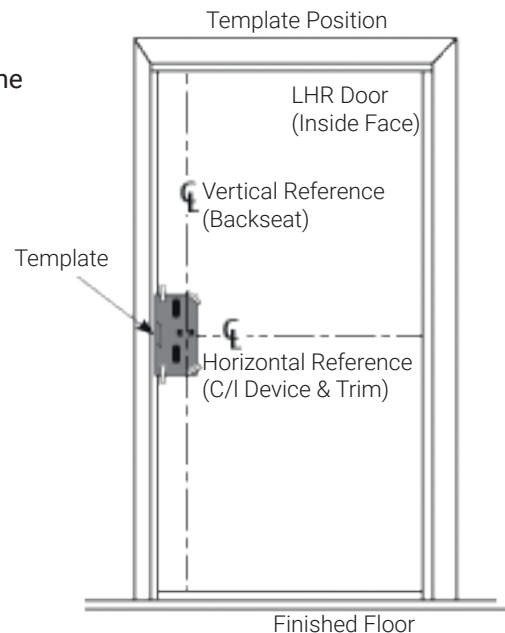

# 6100(F) / 6150 (F) / 6200 /6250 Series

## Rim & SquareBolt® Exit Devices Installation Instructions

**ACCENTRA**

**ASSA ABLOY**

### Prepare Door & Frame with Templates

Do the following using the Plastic Template (Device Seat & Trim)

- Use the template and information provided in Figure 3-B and Table 1 to prepare holes.
- Unreinforced frames (total wall thickness less than 1/8" (3.2mm)) require that 10-24 blind rivet nuts be used to bolt strike.
- Remove template when complete.reinforced.

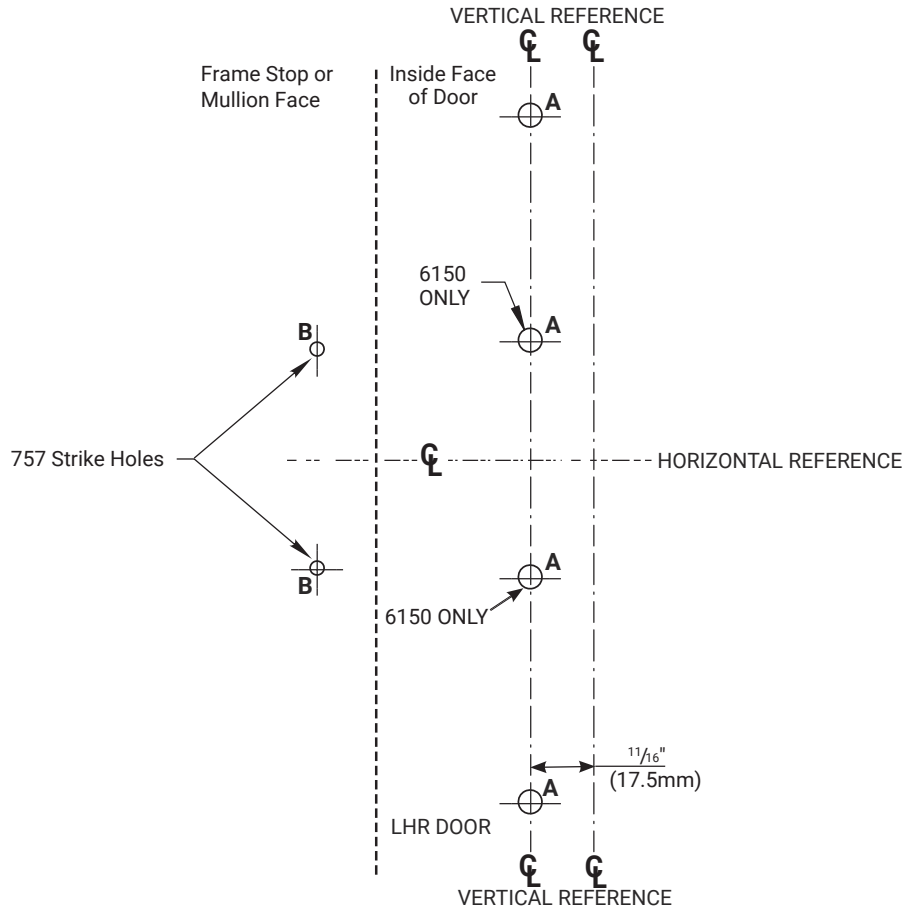

**Figure 3-B: Wide Stile LHR Door Device Preparation**

Table 1: Door & Frame Preparation			
HOLE	DOOR/FRAME	FASTENER	PREPARATION
A	Metal Reinforced	¼-20 PPHMS	Drill: #7 (Ø 0.201") Tap: ¼-20
	All Others	¼-20 SNB	Drill: Ø 3/8" thru
B	Metal Reinforced	#10-24 PPHMS	Drill: #26 (Ø 0.157") Tap: #10-24
	Solid Hardwood	10x1-¼" PPHWS	Pilot Hole: Ø 11/64" (4.4mm)

#### Sizing Exit Device

1. Bar must be cut to size if gap between bar and door stop (stop surface) is less than 27/8" (73mm) (see Figures 4-A, 4-B and Table 2).
2. With door closed, measure 27/8" (73mm) from door stop (stop surface) on hinge side of door. Mark vertical reference line on door.
3. Open door. Align mounting holes in latch head with mounting holes in the door. Mark touch bar where it crosses the mark from step 2 above.
4. Before cutting, ensure end cover is in place and there is no gap between it and the touch bar. Cut touch bar on mark from

**NOTE:** For devices with dogging, hole must be at least 15/8" (41.3mm) from cut end of device.

TABLE 2: STANDARD DEVICE SIZING				
Catalog Size	Door Width		Precut Lengths	
	Minimum	Maximum	Narrow	Wide
24	24" (610mm)	24" (610mm)	-	18.426 (468mm)
36	30" (762mm)	36" (915mm)	32.196" (818mm)	30.426 (773mm)
42	37" (940mm)	42" (1067mm)	38.196" (970mm)	36.426 (925mm)
48	43" (1092mm)	48" (1920mm)	44.156" (1122mm)	42.036 (1068mm)

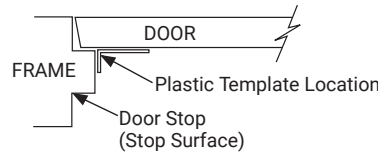

Figure 4-A: Sizing Exit Device

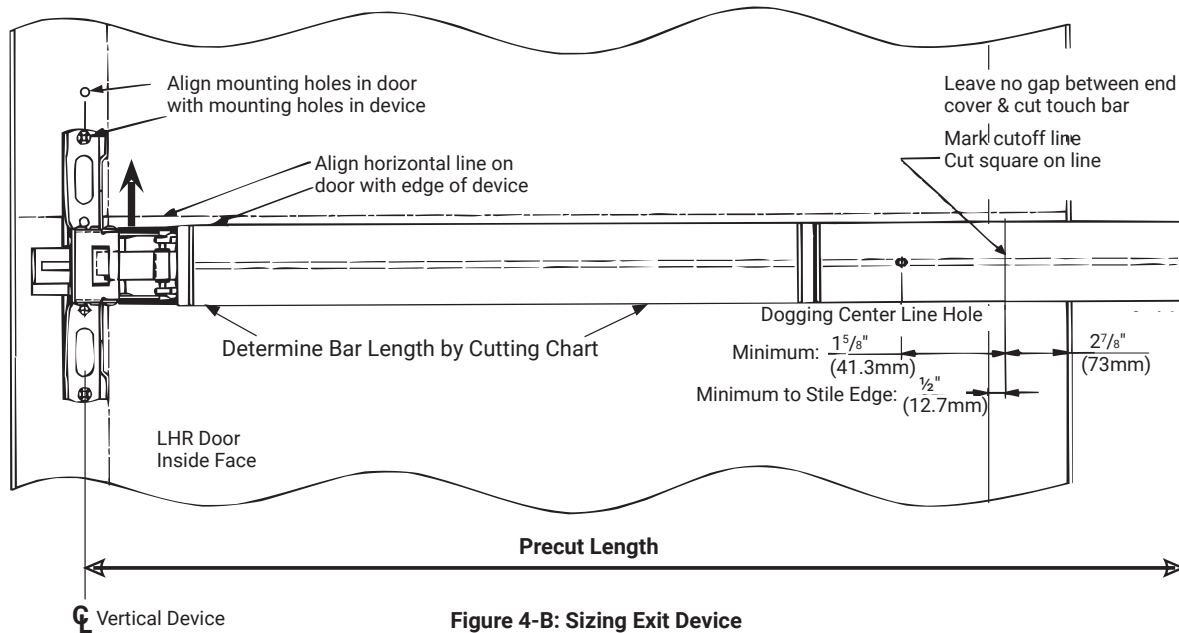

Figure 4-B: Sizing Exit Device



# 6100(F) / 6150 (F) / 6200 /6250 Series

## Rim & SquareBolt® Exit Devices

### Installation Instructions

ACCENTRA

ASSA ABLOY

#### Install Device Assembly

1. Mount trim following instructions packed with trim (optional).
2. Mount shims following instructions packed with shim kit (optional).
3. Loosely attach device assembly to door using  $\frac{1}{4}$ -20 x 1" (25.4) PPHMS. Be sure to line up the tailpiece to fit into the crosshair as shown in Figure 5-A. The tailpiece can be horizontal or vertical to easily slip into the crosshair.

#### NOTE:

- For SquareBolt Device use four (4) screws (Figure 5-B).
- For Rim Device use two (2) screws (Figure 5-C).

4. Level device and slightly tighten screws

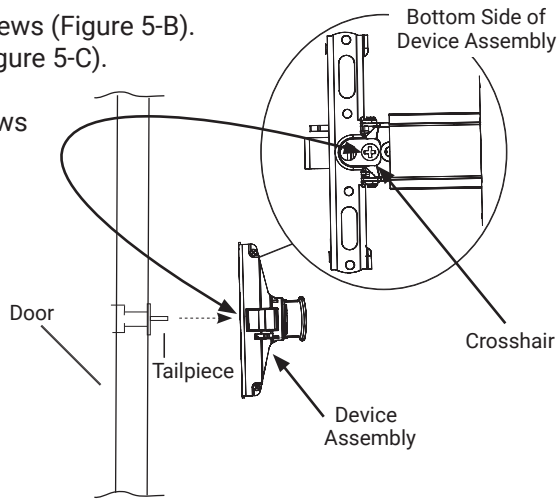

Figure 5-A: Device Assembly Installation

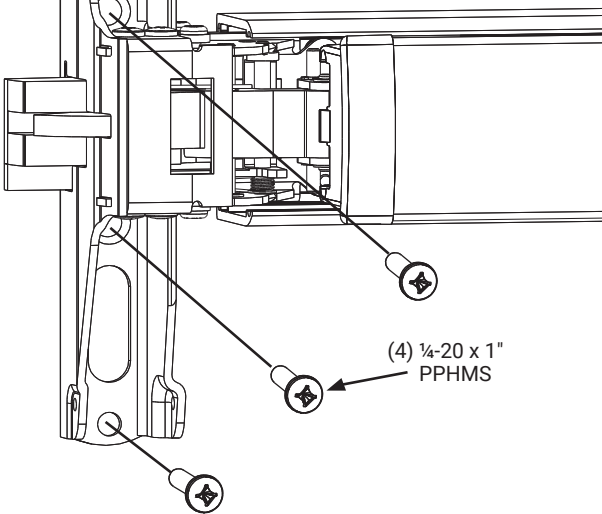

Figure 5-B: SquareBolt® Device Assembly  
(6150 / 6250 Series)

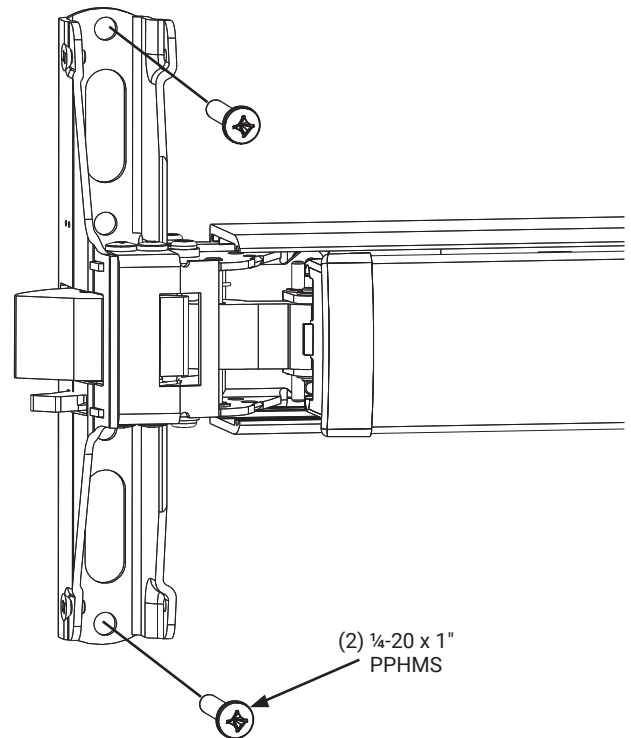

Figure 5-C: Rim Device Assembly  
(6100 / 6200 Series)

#### Sizing Exit Device

1. With the device leveled, locate rear clamp holes and mark (ensure rear clamp is pushed flush against device). Figure 6.
2. Using the rear clamp as a template, mark and drill and tap holes for two (2) ¼-20" screws.
3. Install rear clamp screws and fully tighten all device screws.
4. Slide end cap in place and secure with one (1) #10-24 x ½" (12.7mm) PRHMS.
5. Check Slide Action (full travel = 9/16" (14mm)).

a. The latch and trim will move up when the touchbar is pressed. Release and the latch and trim will return to the original positions.

b. While pressing the touch bar, turn the dogging key CLOCKWISE. Release the touch bar and the latch will remain retracted.

c. While pressing the touch bar, turn the dogging key COUNTER CLOCKWISE. Release the touch bar and the latch will return to the original position.

**NOTES:** If the resulting operation is faulty, check first for visible binding or interference. If there is no apparent reason for the fault, remove the device from the door and recheck its operation before assuming it is defective.

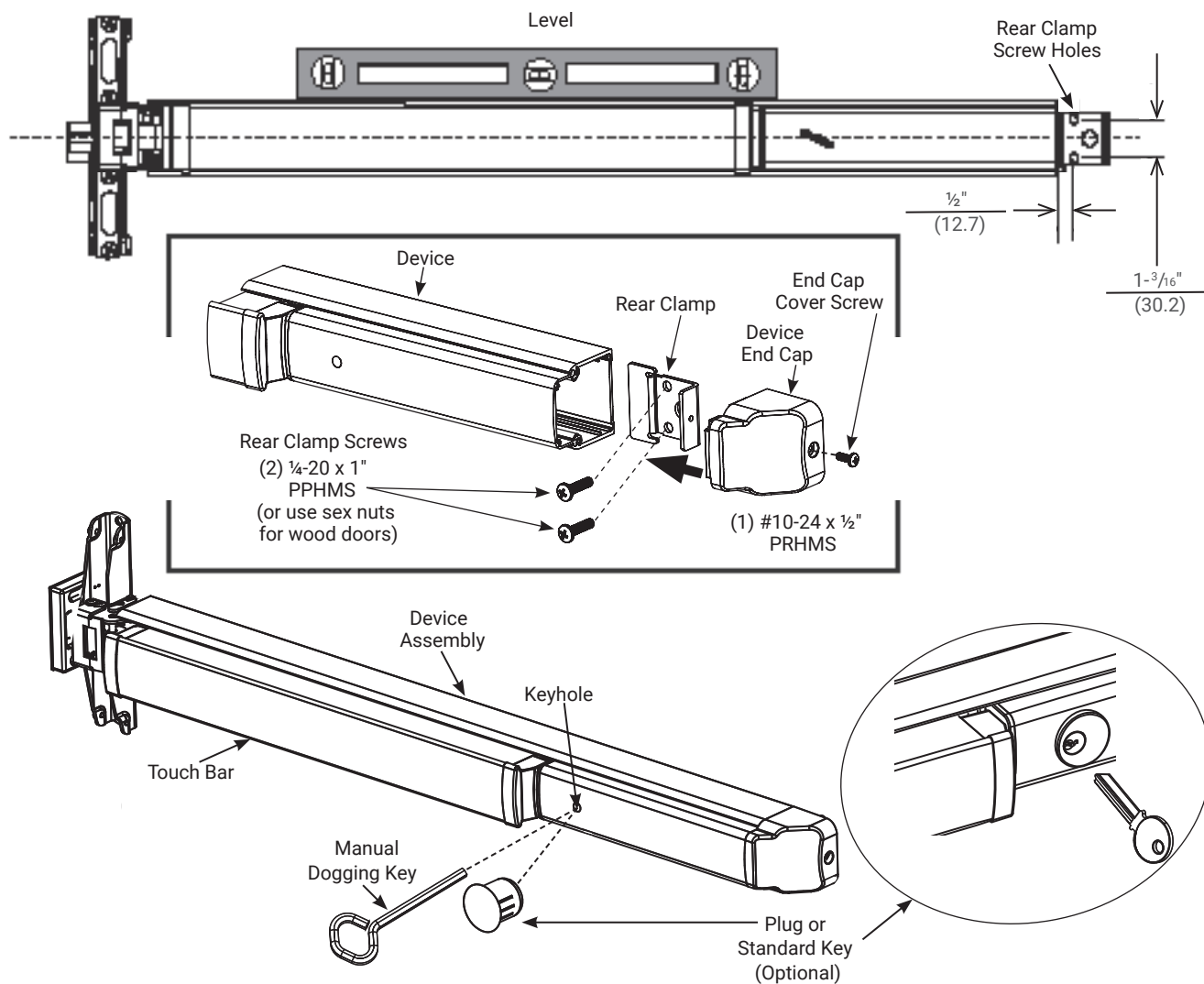

**Figure 6: Install Rear Clamp & End Cap**

# 6100(F) / 6150 (F) / 6200 /6250 Series

## Rim & SquareBolt® Exit Devices Installation Instructions

# ACCENTRA

# ASSA ABLOY

### Install Strike Plate & Shims

1. Align the strike with the holes from Section F (Figure 7-A).
2. Position strike depth by adjusting the shim plates. See Figure 7-B.
3. Fasten the strike securely with two (2) screws. See Figures 7-C and 7-D. Reserve the third screw from the 757 Strike for Step 4.d.
4. Close door and check bolt engagement onto strike. See Figures 7-E and 7-F.
  - a. Bolt will retract to clear strike when touch bar is pressed.
  - b. Bolt will re-engage the strike when touch bar is released and door is shut.
  - c. Door will remain latched and not rattle when pushed, pulled or shaken.
  - d. Drill, tap and install the center screw for the 757 strike.

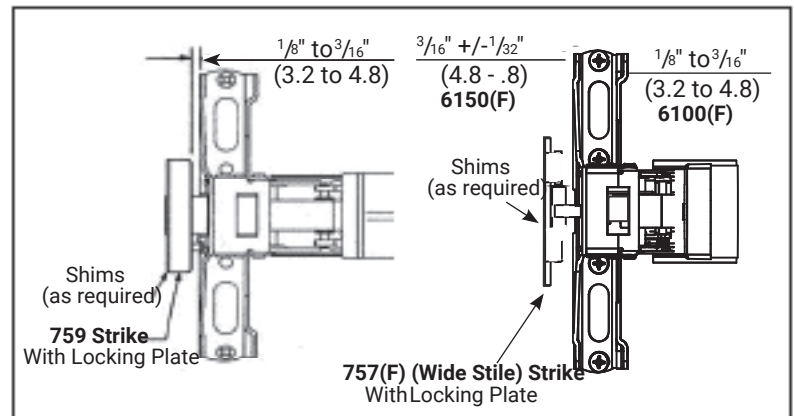

**Figure 7-A: Strike Plate & Shim Installation**

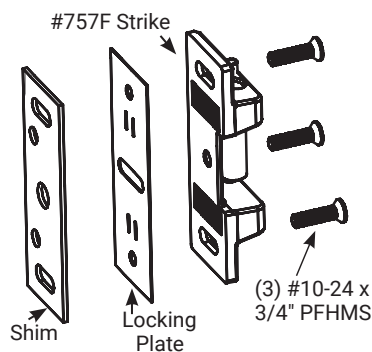

**Figure 7-C: 757 Strike & Shims**

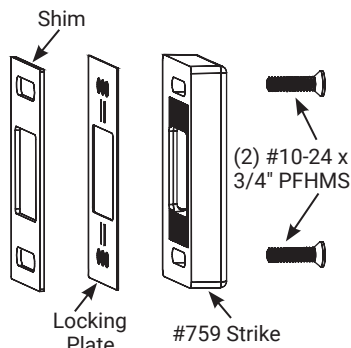

**Figure 7-D: 759 Strike & Shims**

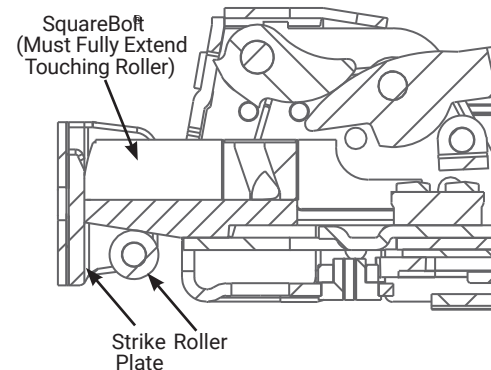

**Figure 7-B: Device Section View**

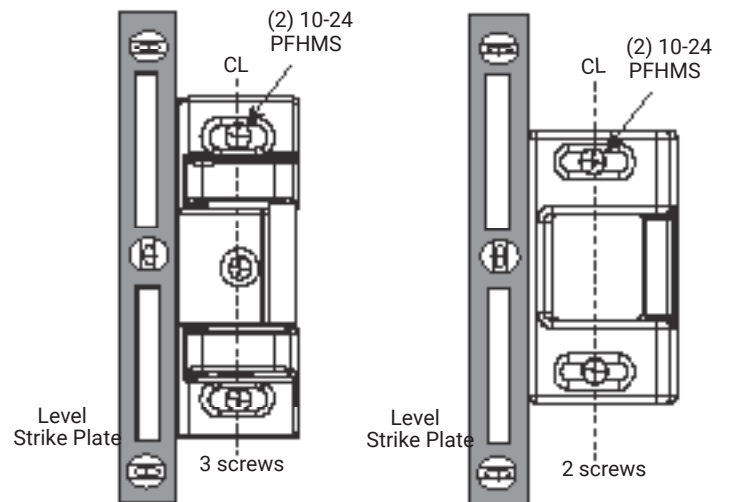

**Figure 7-E: 757 Strike**

**Figure 7-F: 759 Strike**

#### Install Latch Head Cover

1. Secure latch head cover with (2) #8-32 PFHUMS (Figure 8).

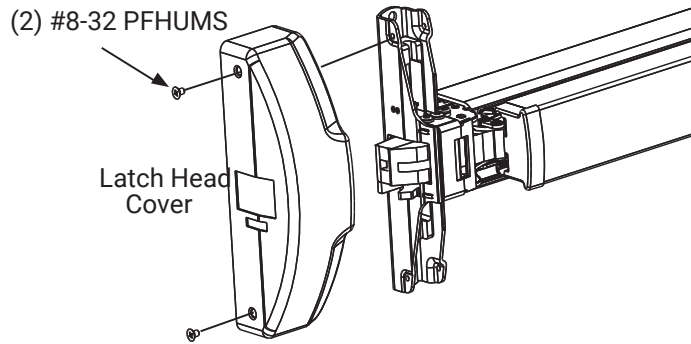

Figure 8: 757 Latch Head Cover Installation

#### Install Latch Head Cover

1. Finally, check and inspect operation of:
  - Trim and device
  - Strike plate and bolt engagement
  - Key (optional)
2. Periodically remove covers, inspect and coat mechanisms with a silicone base lubricant. This is required in corrosive environments for proper functionality.
3. Check mounting fasteners periodically and tighten if loose. Apply screw locking compound or change part fasteners if screws continue to back out.
4. Periodic checks (and adjustments) of strikes are required to compensate for wear and tear (e.g. door sagging).

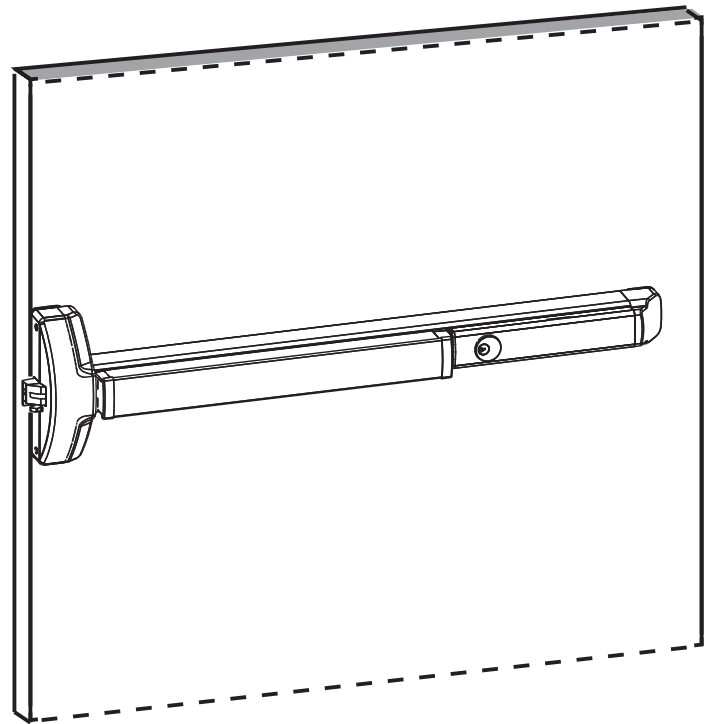

Figure 9: Final Exit Device Assembly







