

PEMKO
DSH1000
DOUBLE SWING HINGE

Experience a safer
and more open world

PRODUCT MUST BE INSTALLED ACCORDING TO ALL APPLICABLE BUILDING AND LIFE SAFETY CODES.

All holes in door and frame must be drilled correctly and fasteners properly installed. DSH1000 must not be cut or shortened under any circumstances.

**Pre-installation note: Follow the frame manufacturer's instructions for proper frame reinforcement.*

Frame Preparation:

1. On hinge jamb side, scribe vertical lines at top and bottom of opening, $1 \frac{15}{16}$ " from push side of door frame face as shown (Fig. 1).
Note: Door leaf of hinge is offset from hinge frame leaf $\frac{1}{8}$ " to allow clearance for door to swing freely.
2. Hold frame leaf of hinge tight against frame header, aligning edge of hinge with top and bottom scribed marks.
3. Block or wedge gap at bottom of hinge to help hold hinge in place.
4. Mark and center punch each hole on frame with hinge held firmly in place (Fig. 2).
For ease of installation, a center punch can help center hole.
5. Drill Holes:
#15 drill bit for 16 gauge metal frames or
#13 drill bit for 12-14 gauge metal frames
If hinge hole is through the frame reinforcement, drill and tap using 12-24 tap.

DO NOT INSTALL HINGE TO FRAME AT THIS TIME.

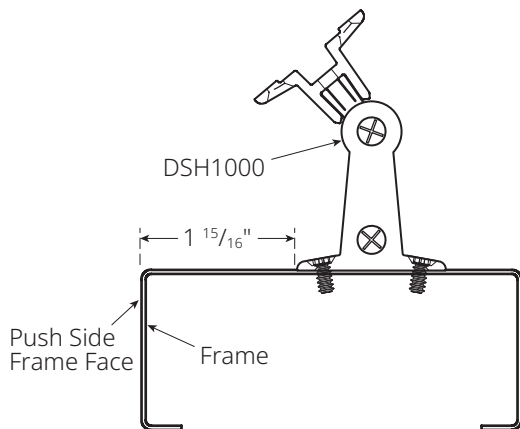
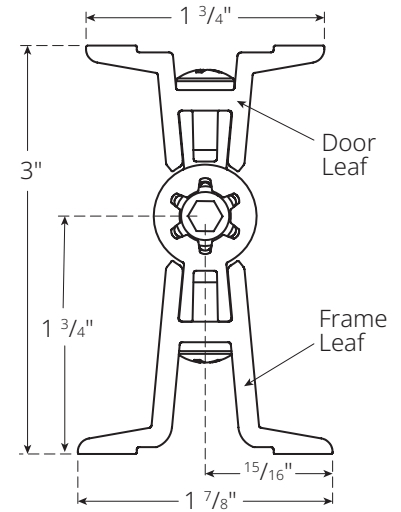

Fig. 1



DSH1000 HINGE

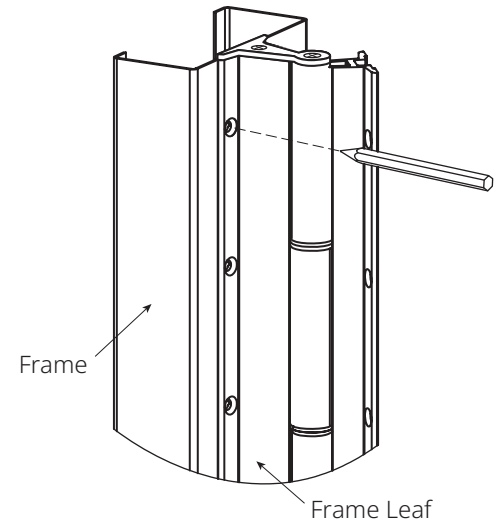
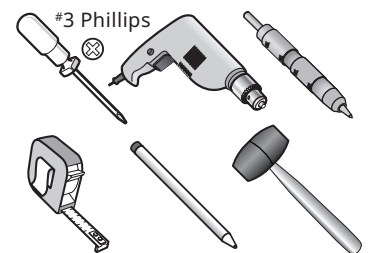

Fig. 2

Tools Required:



Door Preparation:

1. Position door leaf portion of hinge on door so that top of hinge is flush with top of door. Make sure door leaf of hinge is centered on door edge.
2. Mark and center punch each hole on door with hinge held firmly in place (Fig 3). Remove hinge from door and prepare to drill door.

3. Drilling Doors:

Holes should be slightly angled toward center of door. If hollow metal door is reinforced, thread all holes with 12-24 tap.

Ensure drill bit length is not long enough to allow drill bit to go through face of door.

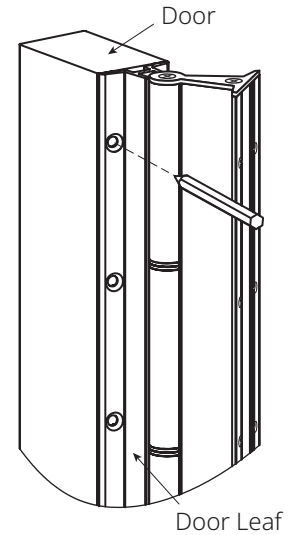

Fig. 3

MATERIAL	THICKNESS	DRILL SIZE
ALUMINUM	0.090-0.	13
METAL	20 GAU	17
METAL	16-18 GAU	15
METAL	12-14 GAU	13
WOOD	N/A	$\frac{5}{32}$ "

Hinge Installation:

1. Attaching hinge to door (Fig 4):
Install screws to attached hinge to door using T-25 driver (Fig. 4).

Wood: Attach hinge using #12-8 x 1 1/2" Torx Flat Head Particle Board Screws (TORX-PBS12150SP10SS).

Hollow Metal: Attach hinge using #12-24 x 1 1/16" Torx Flat Head Undercut Self Drilling Machine Screws (TORX-TKS1267SP10SS).

2. Attaching hinge to frame (Fig 5):
Install screws to attached hinge to frame using T-25 driver (Fig. 5).

Hollow Metal: Attach hinge using #12-24 x 1 1/16" Flat Head Undercut Self Drilling Machine Screws (TORX-TKS1267SP10SS).

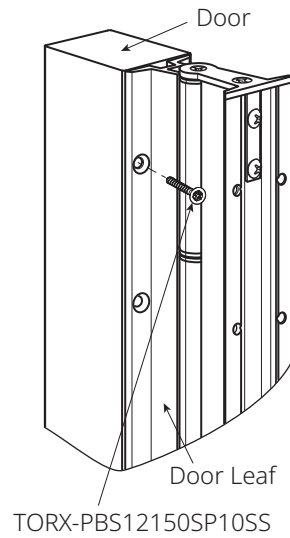

Fig. 4

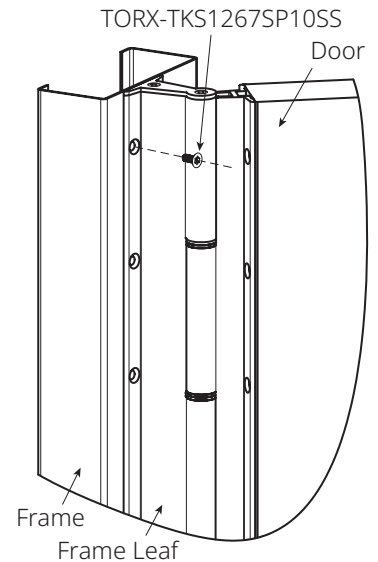

Fig. 5