

# Architectural Door Accessories

**ASSA ABLOY**

## Pemko H800S-SW Sliding Door Hardware

The global leader in  
door opening solutions

**Door Leaf Capacity - Up to 800 lbs.**

Manufactured by  
**HENDERSON**

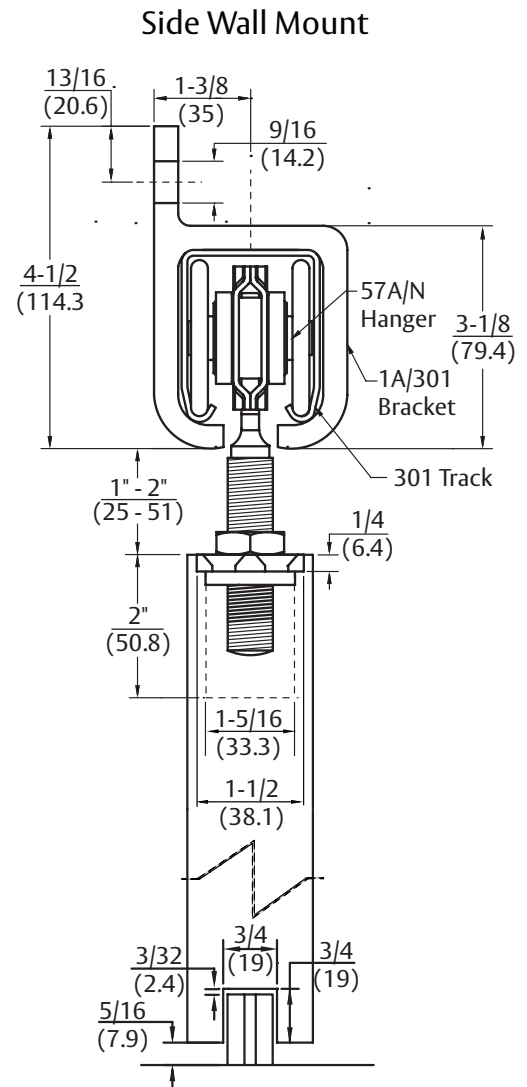
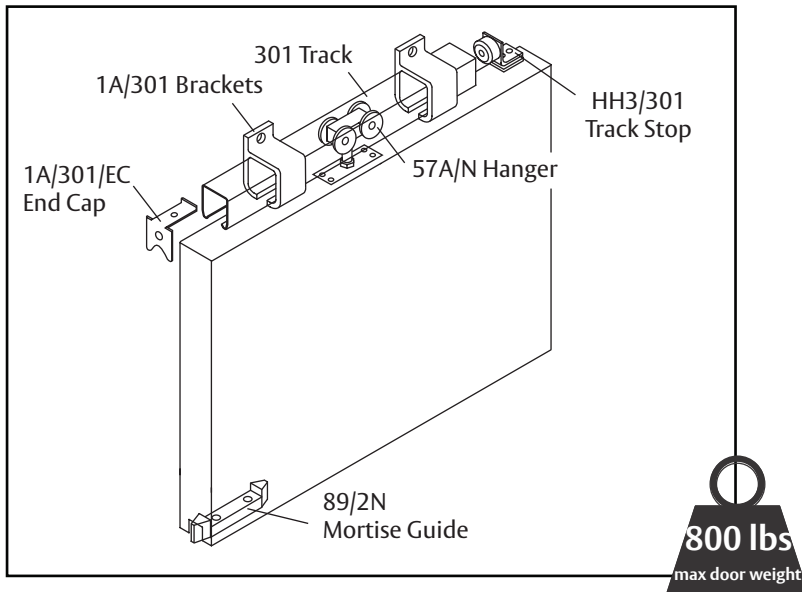

Part Number	Material	Track Length	Door Width
H800S-SW/6	Steel	72"	36"
H800S-SW/8	Steel	96"	48"
H800S-SW/10	Steel	120"	60"
H800S-SW/12	Steel	144"	72"

### H800S-SW Kits Include:

- 1 ea 301 Galvanized Steel Track
- 1A/301 Aluminum Alloy Side Wall Mount Track Brackets  
(One at each end and no more than three feet in between)
- 2 ea 1A/301/EC Aluminum Alloy End Caps
- 2 ea 57A/N Zinc Coated Steel Body, Nylon Wheels, and Pendant Bolt
- 2 ea Hangers
- 1 ea HH3/301 Galvanized Steel In-Track Stops
- 89/2N Gray Nylon Mortise Guide

## 1. Install brackets.

Slide brackets onto track. Inward brackets should be 2' (61m) from each end and centered on track.

Do not install end brackets with end caps at this time.

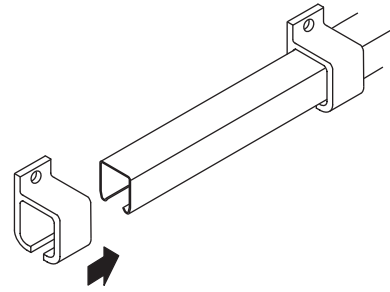

## 2. Secure track to wall.

Ensure track is plumb and level.

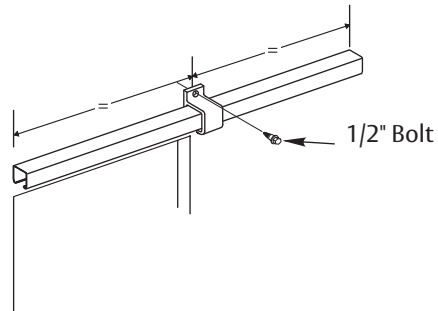

## 3. Mortise door for door guide.

Attach a plumb line to hanger. Remove one end bracket. Place hanger inside track. Using plumb line, mark the centerline of door guide.

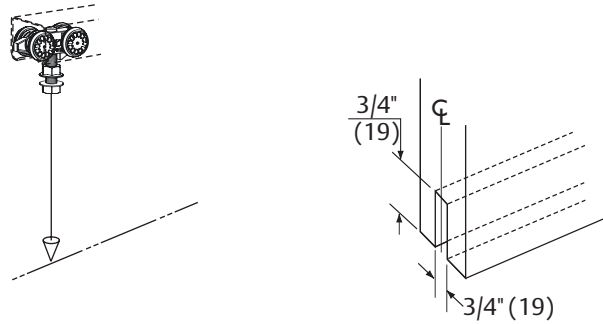

## 4. Fit door guide to floor.

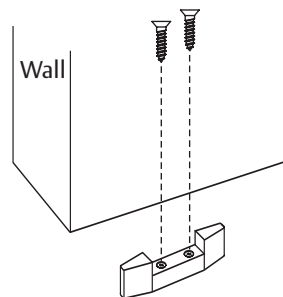

**ASSA ABLOY**

The global leader in  
door opening solutions

Copyright © 2017, Pemko Manufacturing Co., an ASSA ABLOY Group company. All rights reserved.  
Reproduction in whole or in part without the express written permission of Pemko Manufacturing Co. is prohibited.

81010 02/17

2

## 5. Prepare top of door for hanger hardware.

- ① Drill  $1\frac{5}{16}$ " (33.3) dia. x 2" (50.8) deep hole 8" (203.2) from door edge to centerline of hole and centered in thickness of door.
- ② Route door for  $\frac{1}{4}$ " (6.4) thick,  $7\frac{5}{16}$ " (185.7) long, and  $1\frac{1}{2}$ " (38.1) wide plate centered on centerline of hole and thickness of door.

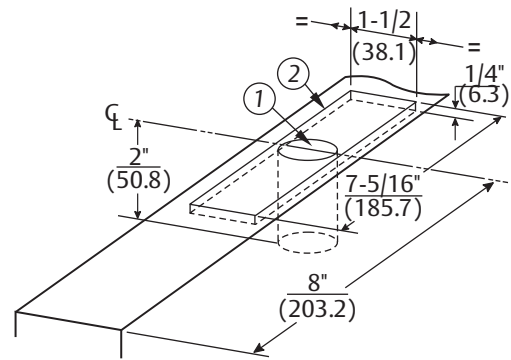

## 6. Attach hangers to doors.

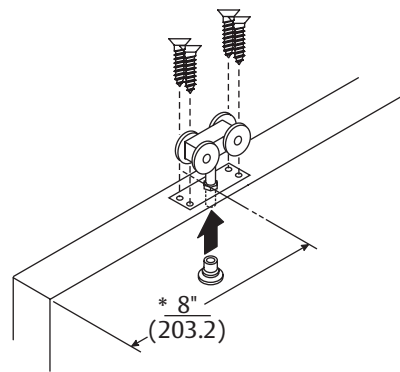

\*From door edge to centerline of hanger bolt and plate.

## 7. Hang door.

Slowly guide complete door unit into track using installed floor guide. Install track stops.

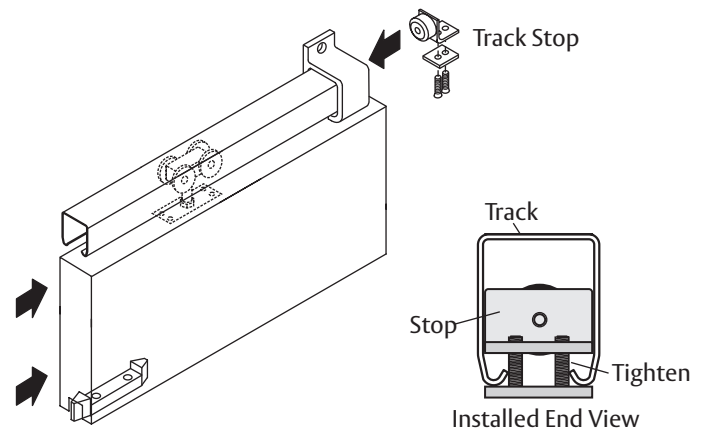

# ASSA ABLOY

The global leader in  
door opening solutions

## 8. Install end bracket caps.

Replace end brackets onto ends of track with end caps in position. Check for smooth operation. Adjust and tighten stops.

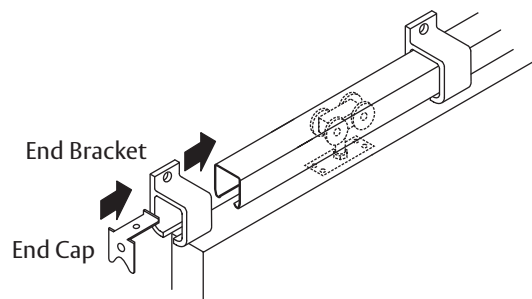

### **IMPORTANT:**

Visually check all bolts and screws; tighten if necessary.  
If access door is installed, check operation.  
Check operation of doors for ease.

- Door catches floor guide: Check that the track is level. Ensure that the track and floor guide are parallel to within  $\pm 1/8$ " (3).
- Door scrubs: Check that the door is level on hangers.
- Door moves while in operation: Check hangers are installed correctly.