

# ED3000 Series Rehanging Lever

In U.S.:  
Corbin Russwin, Inc.  
225 Episcopal Road  
Berlin, CT 06037 USA  
www.corbinrusswin.com

In Canada:  
ASSA ABLOY Door Security Solutions Canada  
160 Four Valley Drive  
Vaughan, Ontario, Canada L4K4T9  
www.assaabloy.ca

**Technical Product Support:** Phone: 888-607-5703

FM369 (03/15)

### Attention:

To prepare door, use instruction sheets and templates packed with exit device and outside trim.

Please keep this instruction sheet for maintenance use.

### General Description

Lever Handle Trim Used  
With ED3400 Surface Mounted  
Vertical Rod Exit Devices

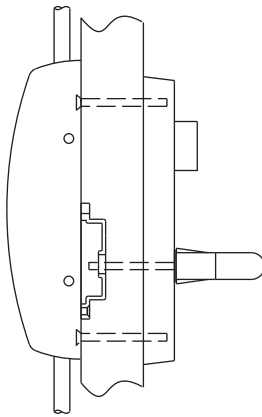

Lever Handle Trim Used  
With ED3200 Rim Exit Devices

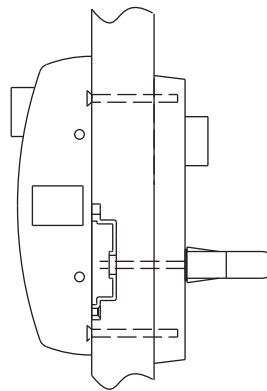

Lever Handle Trim Used  
With ED3600 Mortise Lock  
Exit Devices

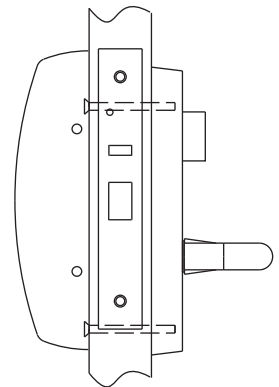

Classroom Trim Shown

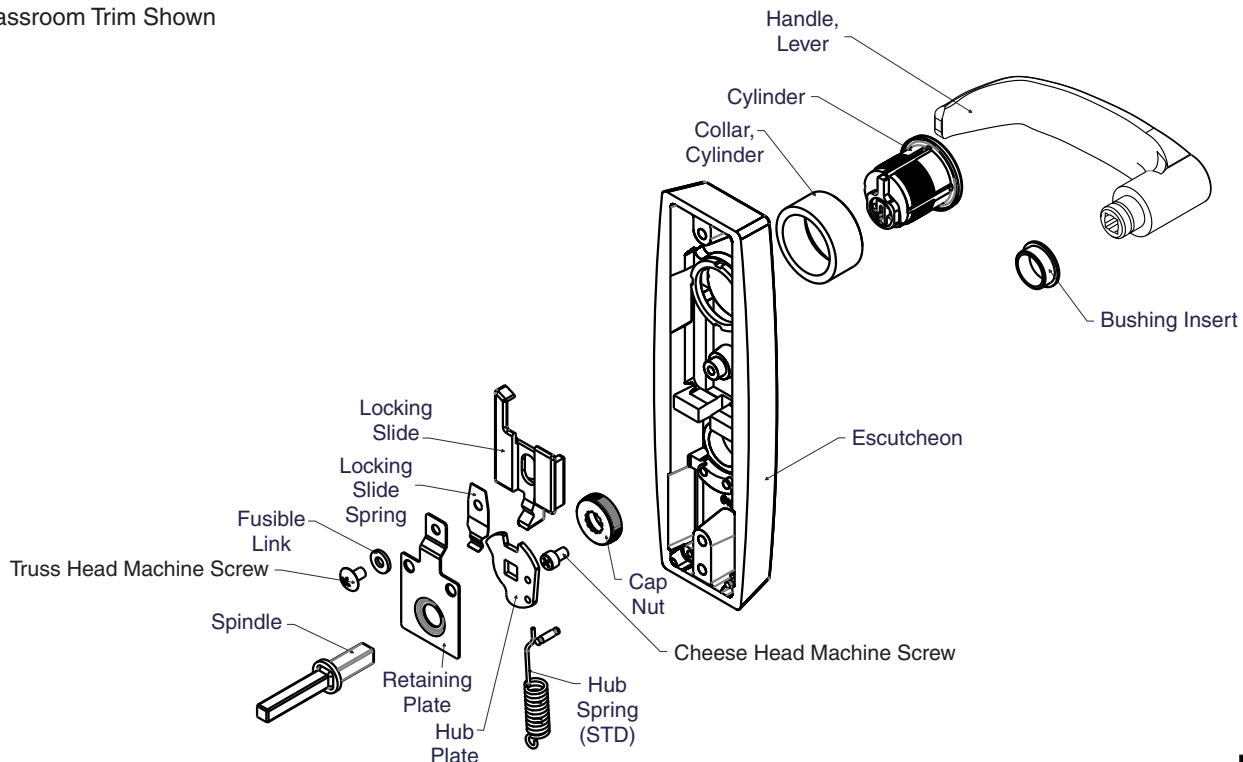

# ED3000 Series Rehanding Lever

## Method For Changing Hand Of Lever

### Disassemble:

1. Remove truss head machine screw, fusible link and retaining plate.
2. Remove hub spring from the groove pin and pull the spindle, hub plate and hub spring out of the lever handle.
3. Remove the stop screw and secure in the other hole.
4. Separate the spindle from the hub plate and place the spindle into the lever handle thru the cap nut.
5. Rotate the lever handle 180° and remove the spindle.

### Reassemble:

1. Flip the hub plate over so that the hub spring mounting hole is on the other side and slide the lower end of the spindle thru the square hole in the hub plate.
2. Slide the spindle and hub plate into the lever handle thru the cap nut, making sure that they are parallel to each other.
3. Slide the hub spring into the lower mounting hole of the hub plate and slide the other end over the groove pin.
4. Slide the retaining plate over the spindle and secure with the fusible link and truss head machine screw.

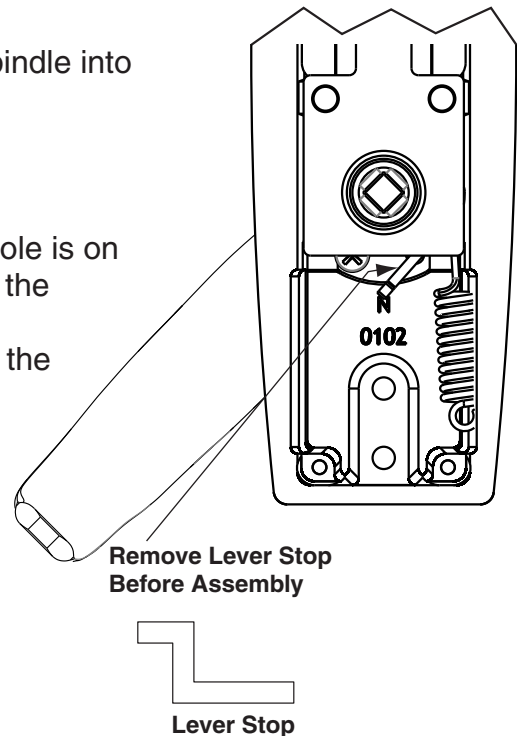

## Method For Replacing Cylinder

1. With locking slide in the down position, unscrew cylinder nut and remove the cylinder and blocking ring. Remove the cylinder nut if needed.
2. Replace cylinder by reversing above procedure, making sure that the cylinder nut is in place and the cam is pointing up. Be sure blocking ring is the correct length.

### Attention:

1. Dirke lever design is not reversible.