

# Instructions for Installing AD-8600, MD-8600 & 12-MD-8600 Concealed Vertical Rod Exit Devices



For additional information, contact SARGENT at 1-800-727-5477

Verify the correct exit device is being installed on the correct door. Function, finish and size should all be verified. **Note: Before removing door from hinges determine the gap between top of door and frame. Determine smallest gap between bottom of door or threshold and high point of floor as door swings. This information is needed for step #7.** Remove door from the frame.

- 1) Drill, tap & c'sink the door per template, except for the (2) #10-24 (4A) on the hinge side.

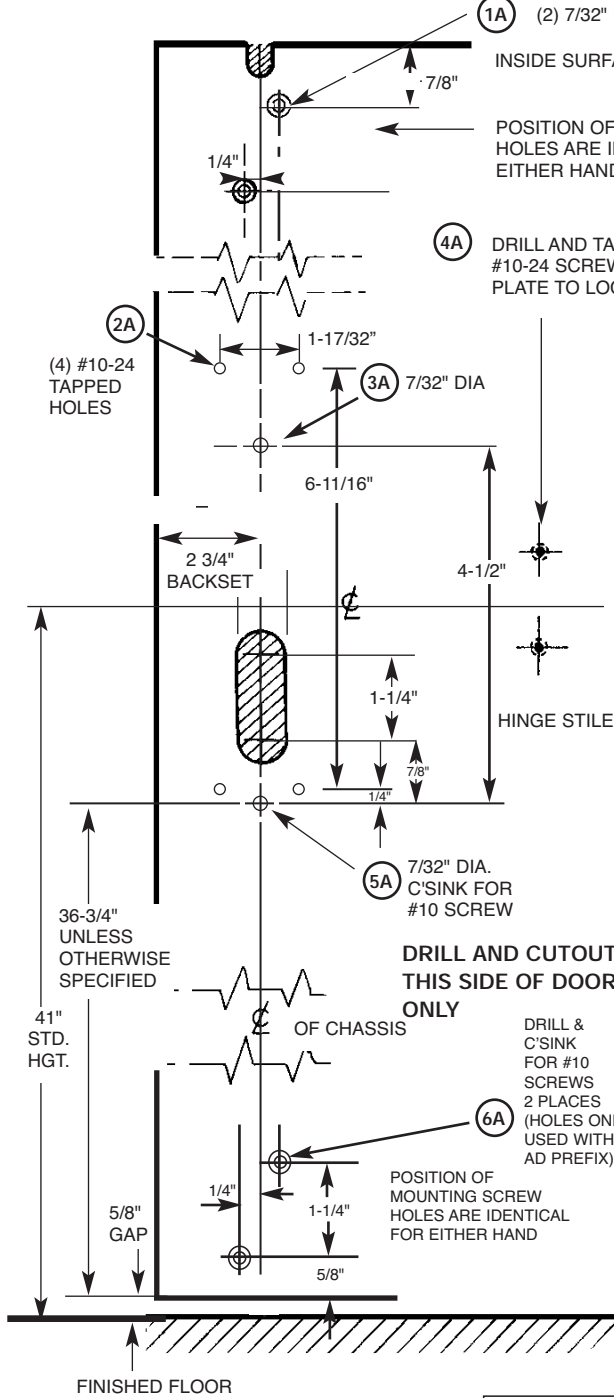

Door prep shown is the same for the MD-8600, 12-MD-8600 and AD-8600 Series exit devices, except for attaching the bottom plate. 12- and MD- is shown separately below.

**Note: If 100 Series auxiliary control is being used, door must be prepped for Aux Control prior to installing device on to the door. Aux Control can be installed after exit device is installed. See appropriate instructions.**

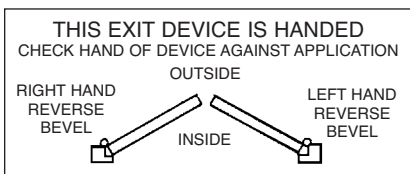
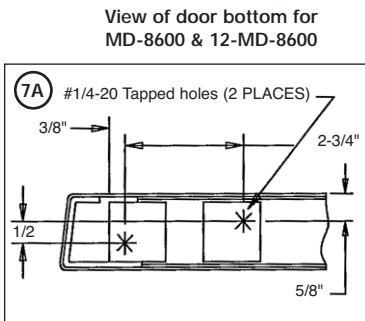

Rail Sizes	Door Widths	
	Max	Min
E	32"	24"
F	36"	33"
J	42"	37"
G	48"	43"

ASSA ABLOY, the global leader in door opening solutions

- 2) Screw top bolt & rod assembly (A) and bottom bolt & rod assembly (C) into inner chassis (B).
- 3) Slide complete assembly into top of door.
- 4) Attach inner chassis (B) to door with screw (GG) using hole (5A).
- 5) Then secure with screw (FF) using hole (3A).

**Note: If 700 Series ET Controls is being used, it must be installed at this point, prior to step 6. See appropriate instructions.**

- 6) Position chassis (D) over fillister head screw and attach to door with (4) screws (AA) using holes (2A). Do not tighten yet.

**Note: Rods must be retracted while adjusting bolt projection. Use Chassis (D) to retract top bolt & rod assy (A) & bottom bolt & rod assy (C).**

## 7A) Adjusting the top bolt & rod assembly (A)

- 1) 1/8" gap or less between door top and frame. Rotate bolt to make even with top of the door.
- 2) 1/8" gap or greater. Bolt to extend above door equal to gap minus an 1/8".

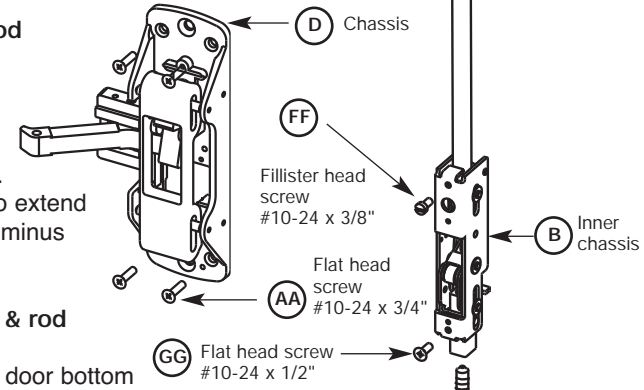

## 7B) Adjusting the bottom bolt & rod assembly (C)

- 1) 1/8" gap or less between door bottom & high point. Rotate bolt to make even with bottom of door.
- 2) 1/8" gap or greater. Bolt to extend below door equal to gap minus an 1/8".

<p>AA Chassis mounting screw metal door application (#10-24 x 3/4" ph. fl. hd. mach. screws, 4 pcs)</p>	<p>BB Rail mounting screw (#8-32 x 3/8" ph. truss head machine screw. by finish 2 pcs)</p>	<p>CC Cover &amp; end cap mounting screw (#8-32 x 5/16" with #6 ph. ov. u'cut hd. machine screw, by finish 6 pcs)</p>
<p>DD Bottom case mounting screw (1/4"-20 x 1/2" ph. fl. hd. mach. screw 2 pcs) [not used with nb prefix]</p>	<p>EE End cap mounting bracket (#10-24 x 3/4" ph. rd. hd. mach. screw 4 pcs)</p>	
<p>FF Aligning and inner chassis screw (#10-24 x 3/8" ph. fillister hd. machine screw, 1 pcs)</p>	<p>GG Inner chassis bottom screw &amp; top strike screws (# 10-24 x 1/2" ph. fl. hd. mach. screws, 3 pcs)</p> <p>ET mounting screw (1/4"-20 x 2 3/8" ph. fl. hd. mach. screw 2 pcs)</p> <p>For 1 3/4" door length shown size varies by 1/4" depending on width of cladding or inside panel</p>	<p>HH Top case and bottom case mounting screws (#10-24 x 3/8" ph. ov. hd. machine screw, 4 pcs) [Only 2 pcs used with 12, MD and NB prefix]</p>

## STRIKE PACK FOR AD-8600

640 TOP AND BOTTOM STRIKE

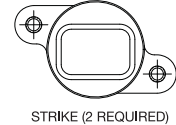

#10 x 1/2" PHILLIPS FLAT HEAD MACHINE SCREW (4 IN PACK FOR TOP AND BOTTOM STRIKE)

## STRIKE PACK FOR MD-8600 & 12-MD-8600

650 TOP STRIKE

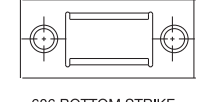

#10-24 X 1/2" PHILLIPS FLAT HEAD MACHINE SCREW (2 IN PACK FOR TOP STRIKE)

606 BOTTOM STRIKE



MACHINE SCREW AND ANCHOR (2 PIECES)



**Manual dogging key**  
(not used with 12-)

To operate: Depress push rail, insert hex key (or cylinder key when used) and turn clockwise.

Not furnished with 12-MD8600

# Instructions for Installing NB-AD-8600, NB-MD-8600 & 12-NB-MD-8600 Concealed Vertical Rod Exit Devices without Bottom Bolt

**SARGENT**  
**ASSA ABLOY**

For additional information, contact SARGENT at 1-800-727-5477

Verify the correct exit device is being installed on the correct door. Function, finish and size should all be verified.

**Note: Before removing door from hinges determine the gap between top of door and frame.** This information is needed for step #7. Remove door from the frame.

- 1) Drill, tap & c'sink the door per template, except for the (2) #10-24 (4A) on the hinge side.

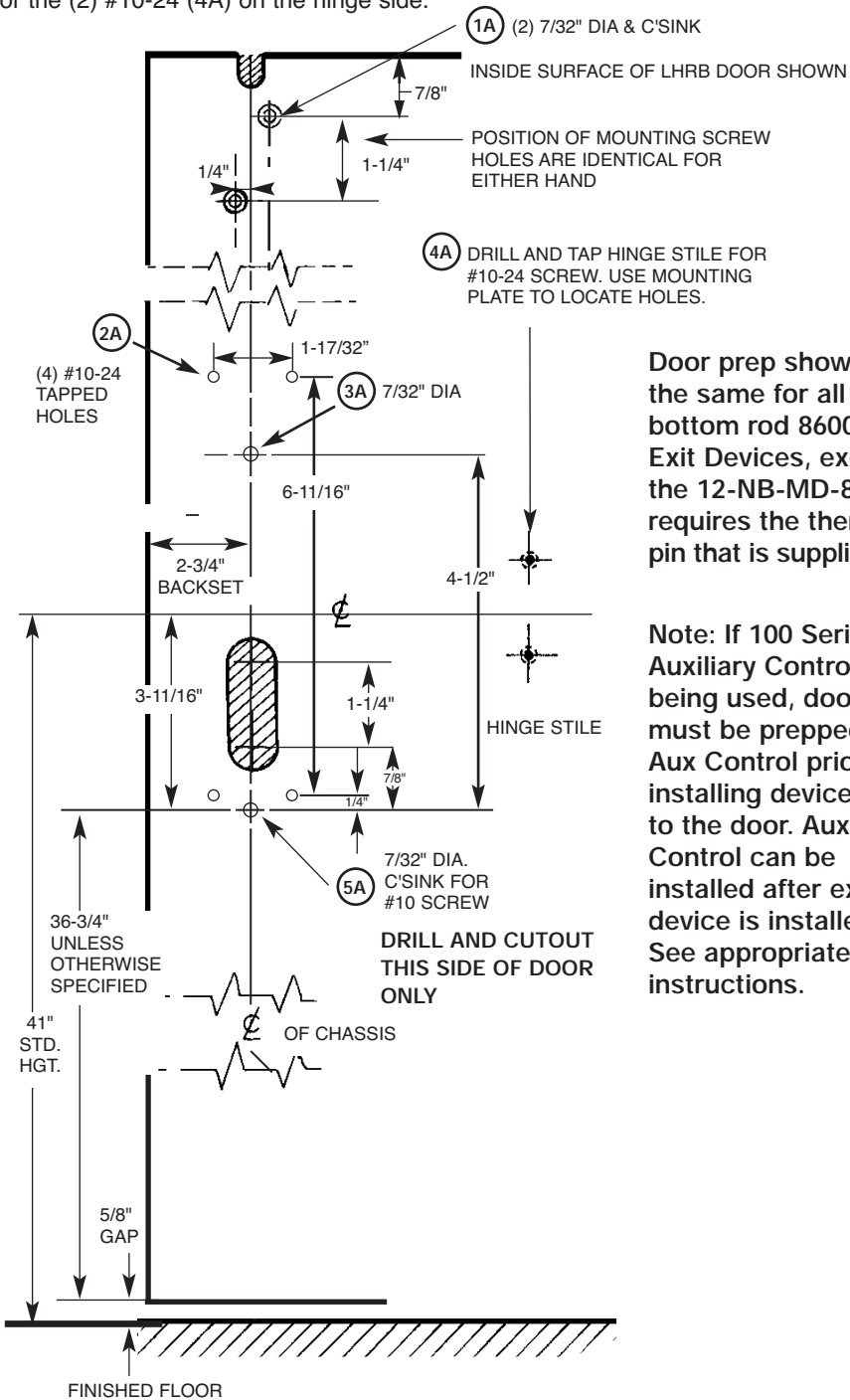

Door prep shown is the same for all less bottom rod 8600 Exit Devices, except the 12-NB-MD-8600 requires the thermal pin that is supplied.

**Note: If 100 Series Auxiliary Control is being used, door must be prepped for Aux Control prior to installing device on to the door. Aux Control can be installed after exit device is installed. See appropriate instructions.**

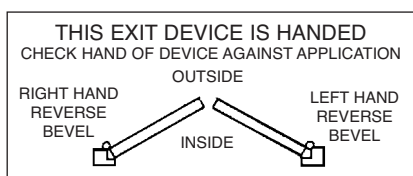

Information for Cutting Rails		
Rail Sizes	Door Widths	
	Max	Min
E	32"	24"
F	36"	33"
J	42"	37"
G	48"	43"

ASSA ABLOY, the global leader in door opening solutions

- 2) Screw top bolt & rod assembly (A) into inner chassis (B).
- 3) Slide complete assembly into top of door.
- 4) Attach inner chassis (B) to door with screw (GG) using hole (5A).
- 5) Then secure with screw (FF) using hole (3A).
- 6) Position chassis (D) over fillister head screw and attach to door with (4) screws (AA) using holes (2A). Do not tighten yet. Use chassis (D) to retract top bolt & rod assy (A) to adjust bolt projection.

**Note: Rod must be retracted while adjusting bolt projection. Use chassis (D) to retract top bolt & rod assy (A).**

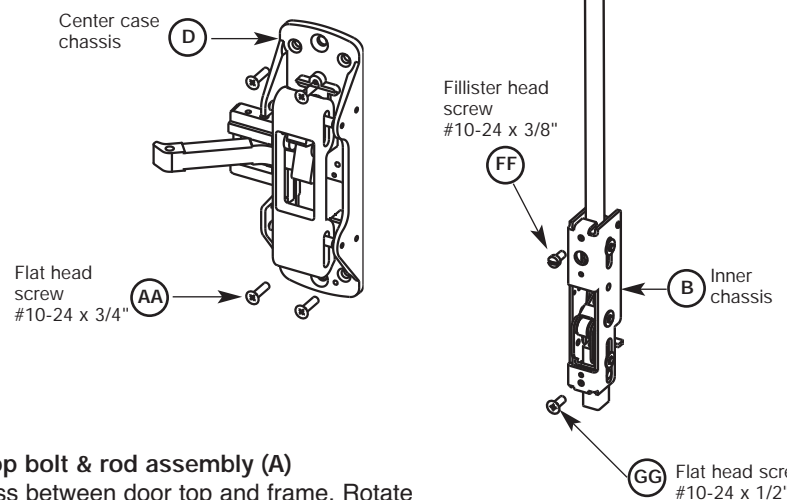

## 7) Adjusting the top bolt & rod assembly (A)

- 1) 1/8" gap or less between door top and frame. Rotate bolt to make even with top of the door.
- 2) 1/8" gap or greater. Bolt to extend above door equal to gap minus an 1/8".

<p>Chassis mounting screw metal door application (#10-24 x 3/4" ph. fl. hd. mach. screws, 4 pcs)</p>	<p>Rail mounting screw (#8-32 x 3/8" ph. truss head machine screw. by finish 2 pcs)</p>	<p>Cover &amp; end cap mounting screw (#8-32 x 5/16" with #6 ph. ov. u'cut hd. machine screw, by finish 6 pcs)</p>
<p>Aligning and inner chassis screw (#10-24 x 3/8" ph. fillister hd. machine screw, 1 pcs)</p>	<p>End cap mounting bracket (#10-24 x 3/4" ph. rd. hd. mach. screw 4 pcs)</p>	<p>Top case mounting screw (#10-24 x 3/8" ph. ov. hd. machine screw 2 pcs)</p>
<p>Inner chassis bottom screw &amp; top strike screws (#10-24 x 1/2" ph. fl. hd. mach. screws, 3 pcs)</p>	<p>ET mounting screw (1/4"-20 x 2 3/8" ph. fl. hd. mach. screw 2 pcs) For 1 3/4" door length shown size varies by 1/4" depending on width of cladding or inside panel</p>	

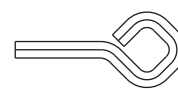

**Manual dogging key** (not used with 12-) To operate: Depress push rail, insert hex key (or cylinder key when used) and turn clockwise. Not furnished with 12-MD

