

Installation Instructions

PE80 & 80 Series Rim Exit Device Applying the 814 "S" Series Trims

Attention: For proper trim installation, use the exit device instruction sheet and template(s). These instructions are for applying 814 pulls to 8888/8810 and 8804 chassis with "Figure 8" mounting holes (manufactured after February 12, 2001.)

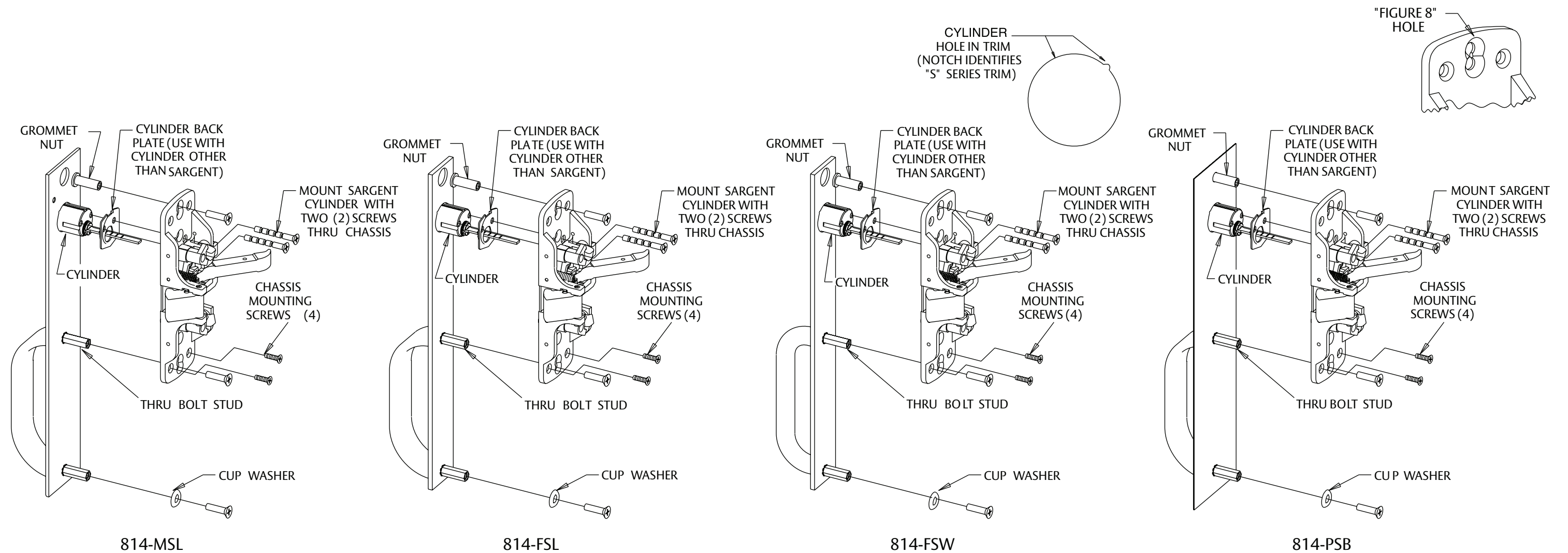

⚠ WARNING

This product can expose you to lead which is known to the state of California to cause cancer and birth defects or other reproductive harm. For more information go to www.P65warnings.ca.gov.

⚠ WARNING

Attention Installer: Improper installation may result in damage to the product and void the factory warranty.

Copyright © 2010, 2023, SARGENT Manufacturing Company. All rights reserved. Reproduction in whole or in part without the express written permission of SARGENT Manufacturing Company is prohibited. Patent pending and/or patent www.assaabloydss.com/patents.