

Product Description

F-Series is Fleming's standard 16 gage paintable galvaneal steel, knocked-down, masonry profile, punch mitered frame, used in masonry, concrete or drywall partitions. It is convertible to set-up and welded (SUW) construction and is available for up to 3 hour fire rated applications in sizes to 4'0" x 10'0" (1250 x 3050mm) singles and 8'0" x 10'0" (2450 x 3050mm) pairs. Installation instructions for both knocked-down and set-up and welded F-Series frames are included in [TDS G09](#).

Standard Sizes and Hardware Locations

Non-standard sizes to suit specific project requirements are also available. Refer to TDS G03 through G06 for detailed information of hinge and strike locations.

All metric values are shown in millimeters (mm) unless indicated otherwise. Imperial and metric values may not be equal.

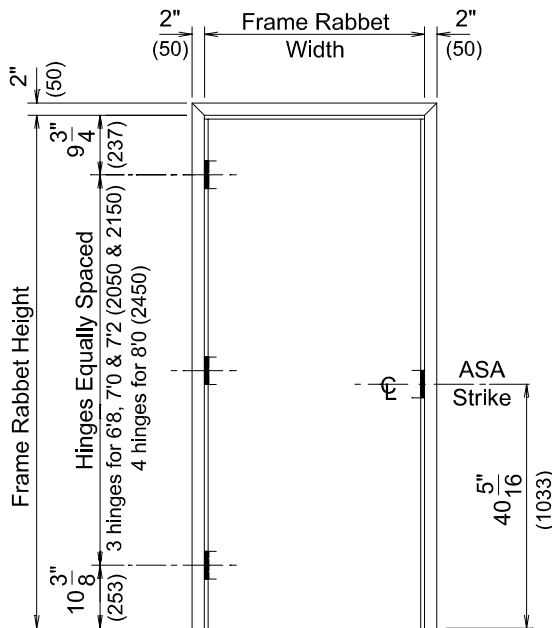

Standard Frame Rabet Sizes			
Frame Rabet Heights	Frame Rabet Widths		
	Singles		Pairs
6'8" 2050mm	2'0" 600mm	4'0" 1200mm	
	2'2" 700mm	4'8" 1400mm	
	2'4" 700mm		
7'0" 2150mm	2'6" 800mm	5'0" 1600mm	
	2'8" 800mm	5'4" 1600mm	
	2'10" 900mm	6'0" 1800mm	
7'2" 2150mm	3'0" 900mm	6'4" 1800mm	
	3'4" 1000mm	6'8" 2000mm	
	3'6" 1000mm	7'0" 2000mm	
8'0" 2450mm	3'8" 1100mm	7'4" 2200mm	
	4'0" 1200mm	8'0" 2400mm	
	4'0" 1200mm		

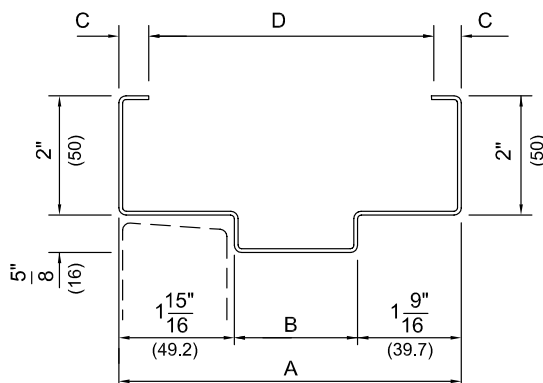

A Jamb Depth	B Soffit	C Return	D Throat
4 3/4 (121)	1 1/4 (31.8)	1/2 (12.7)	3 3/4 (95.3)
5 3/4 (146)	2 1/4 (57.2)	7/16 (11.1)	4 7/8 (123.8)
6 3/4 (172)	3 1/4 (82.5)	1/2 (12.7)	5 3/4 (146.1)
7 3/4 (197)	4 1/4 (108)	1/2 (12.7)	6 3/4 (171.5)
8 3/4 (222)	5 1/4 (133.4)	1/2 (12.7)	7 3/4 (196.9)

Product Features

All F-Series Frames

- Components manufactured from paintable galvaneal steel
- Jambs and heads machine punched for tight, true fitting corner miters
- All jambs provided with 2 projection welded 20 gage corner clips

Typical Head

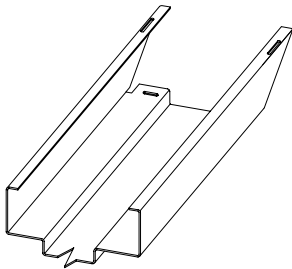

Assembled KD Corner

- Corner clip tabs bent over in field

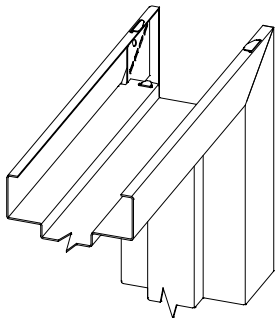

Typical Hinge Jamb

- Projection welded 10 gage High Frequency Reinforcing at all cutouts
- Dimpled to convert from standard to heavy weight hinge
- 22 gage dust boxes standard
- All hinge jambs provided with embossed UL fire label

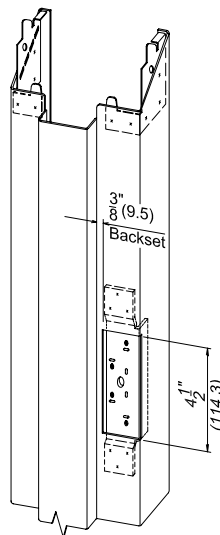

Typical Strike Jamb

- Projection welded 16 gage ASA strike reinforcing (ANSI A115.1-2)
- Integral 1" deep dust box
- Machine punched for door silencers

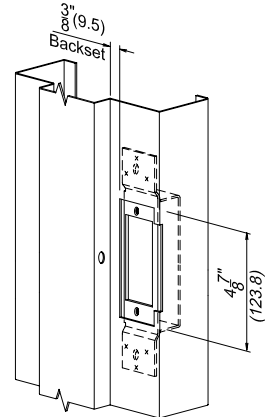

Floor Anchor Strap

- Projection welded 16 gage steel at base of each hinge and strike jamb

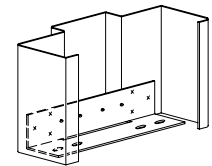

Wall Anchors

Wire Anchor (WA)

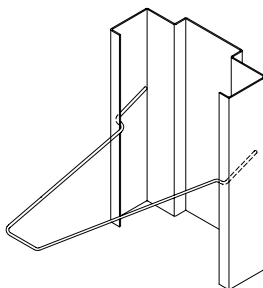

Combination Stud Anchor (CSA)

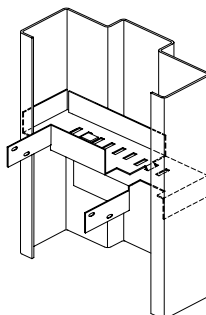

Existing Wall Anchor (EWA)

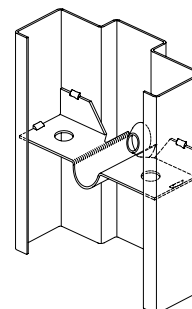

Wood Stud Anchor (WSA)

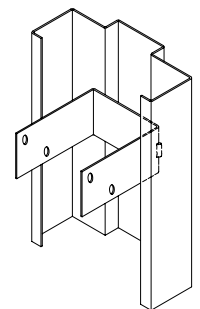

Options

Surface Closer Reinforcing

- 12 gage galvalneal steel

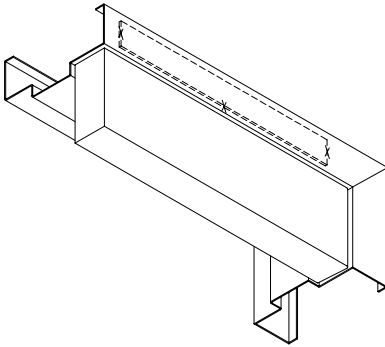

Parallel Arm Closer Reinforcing

- 12 gage galvalneal steel

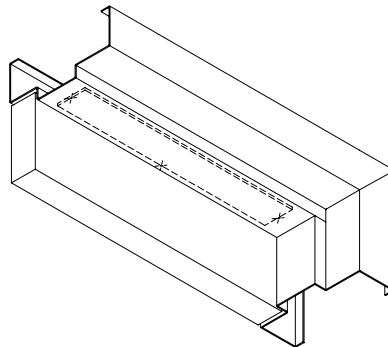

Set-Up and Welded Corner

- Top portion of corner clips removed
- Jamb rabbet tabs inserted through head slots and bent over
- Intersecting face miter joints continuously welded on inside of profile
- Exposed faces filled and ground smooth

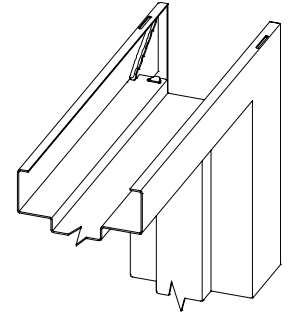

Reversible Flush Bolt Strike

- ANSI A115.4
- 16 gage chromated galvalneal steel

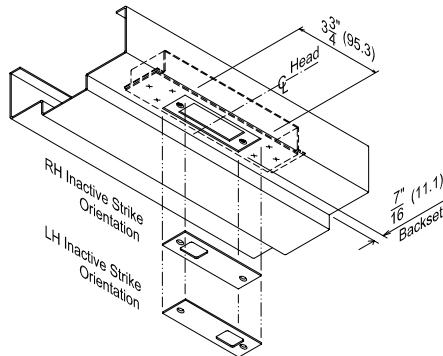

Small ASA N/L (Deadbolt) Strike

- ANSI A115.3
- 14 gage galvalneal steel

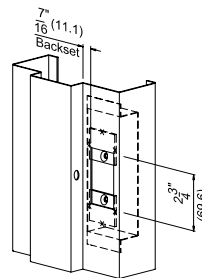

Adjustable Floor Anchor

- 16 gage galvalneal steel
- 1-1/4" (32mm) max. travel

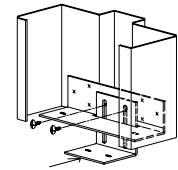

In addition to the typical options above, Fleming offers the following to fully customize F-Series frame product to suit project or opening specific requirements:

- 12 or 14 gage paintable galvalneal steel
- 12, 14 or 16 gage G90 (Z275) galvanized steel
- Non-standard imperial or metric (SI) nominal widths and heights
- Non-standard face widths and jamb depths
- Custom profiles including; drywall returns, plaster returns, equal rabbets, single rabbet, shadow line, hospital profile, contra-swing
- Sanitary bases
- Non-standard hinge or strike locations, back-sets, weights and reinforcing thickness
- Non-standard hinge and strike preparations
- Head preparations for surface, concealed or semi-concealed closers or holders, flush bolt strikes, vertical rod exit device strikes, door position switches and magnetic locks
- Lead lining
- Stainless steel (FSS-Series, see [TDS F11](#))

Specifications

- 1) Frames shall be F16-Series as manufactured by Fleming.
- 2) Frame components shall be straight and uniform throughout their lengths, fabricated from tension leveled steel to ASTM A924, galvanized to ASTM A653, coating designation A40 (ZF120), known commercially as paintable galvalume.
- 3) Corner joints shall be accurately mitered and tightly fitted with integral door stops butted.
- 4) Frame construction shall be knocked-down and shipped unassembled. Corners shall be provided with 20 gage steel reinforcements and tabs which securely interlock mechanically with factory prepared heads.
[Alternate: Frame construction shall be set-up and welded, shipped assembled. Corner joints shall be welded on the inside of the profiles' returns and faces with exposed faces filled and ground smooth. Each door opening shall be provided with 2 temporary steel jamb spreaders, welded to the base of the unit to maintain proper alignment during shipping and handling and shall be removed prior to anchoring of frame to floor.]
- 5) All reinforcements shall be projection, spot or arc welded securely to frame
- 6) Frames shall be blanked, reinforced, drilled and tapped for fully templated mortised hardware or reinforced only for surface hardware.
- 7) Hinge reinforcing shall be 10 gage steel, high frequency type for templated 4-1/2" (114.3) hinges, convertible from standard to heavy weight, with 22 gage steel dust box at each cutout.
- 8) Strike reinforcing shall be 16 gage steel to suit ASA (ANSI A115.1-2) strike with 1" deep integral dust box
- 9) Flush bolt strikes (ANSI A115.4), when specified, shall be reversible type, 16 gage chromated steel
- 10) When specified, reinforcements for surface mounted hardware, concealed closers and holders shall be 12 gage steel.
- 11) Frames shall be provided with anchorage appropriate to floor, wall and frame construction. Each wall anchor shall be located immediately above or below each hinge reinforcement and directly opposite on the strike jamb.
- 12) Each jamb shall be provided with 16 gage steel floor anchors.
- 13) Each door opening shall be prepared for GJ-64 or equivalent single stud door silencers, 3 per strike jamb for single door openings, 2 per head for pairs.
- 14) On exposed surfaces where zinc has been removed during fabrication, frames shall receive a factory applied touch-up primer.
- 15) Contractor responsible for installation shall remove all wraps or covers upon delivery at building site, store on planks or dunnage in a dry location in a vertical position, space with blocking to permit air circulation between them and cover to protect from all damage.
- 16) Set frames plumb, square, aligned, without twist at correct elevation in accordance with Fleming TDS [G09](#), NAAMM-HMMA 840, "Installation Guide for Commercial Steel Doors and Frames" and for fire rated product, NFPA 80.
- 17) Prior to site touch-up, exposed surfaces of galvalume steel to be finish painted with latex paints shall be cleaned with soap and water. When alkyd finish paints are specified, turpentine or paint thinners shall be used.
- 18) Exposed surfaces which have been scratched or otherwise marred during shipping, handling or installation shall be touched-up with a rust inhibitive primer.
- 19) Finish paint in accordance with Section 09900.