

4400 Series Slide Track Door Closer

Models 4400ST, P4400ST, 4410ST, and P4410ST

Pull or Push Side, Non-Hold Open or Hold Open

Installation Instructions

ACCENTRA

ASSA ABLOY

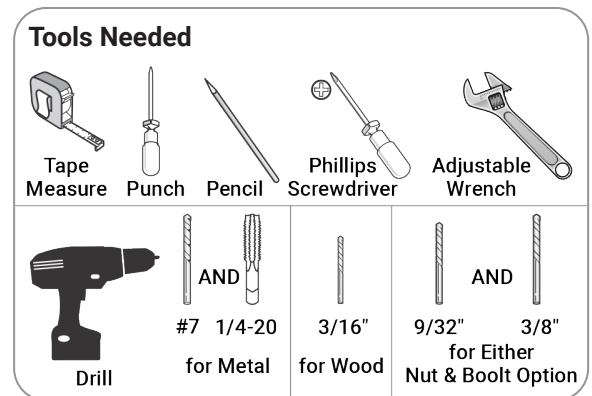
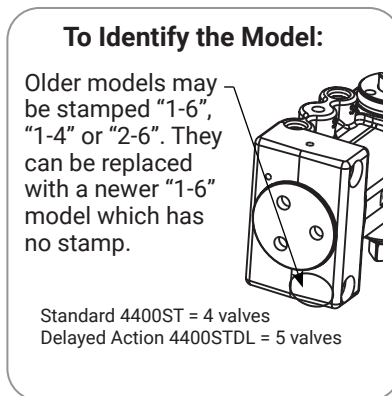
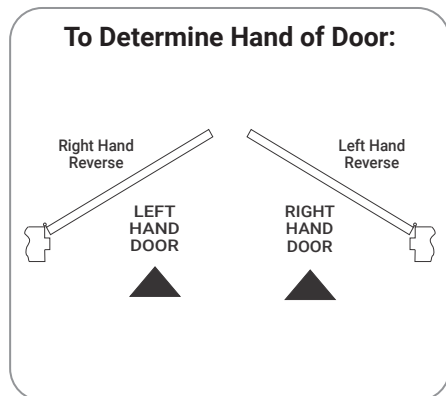
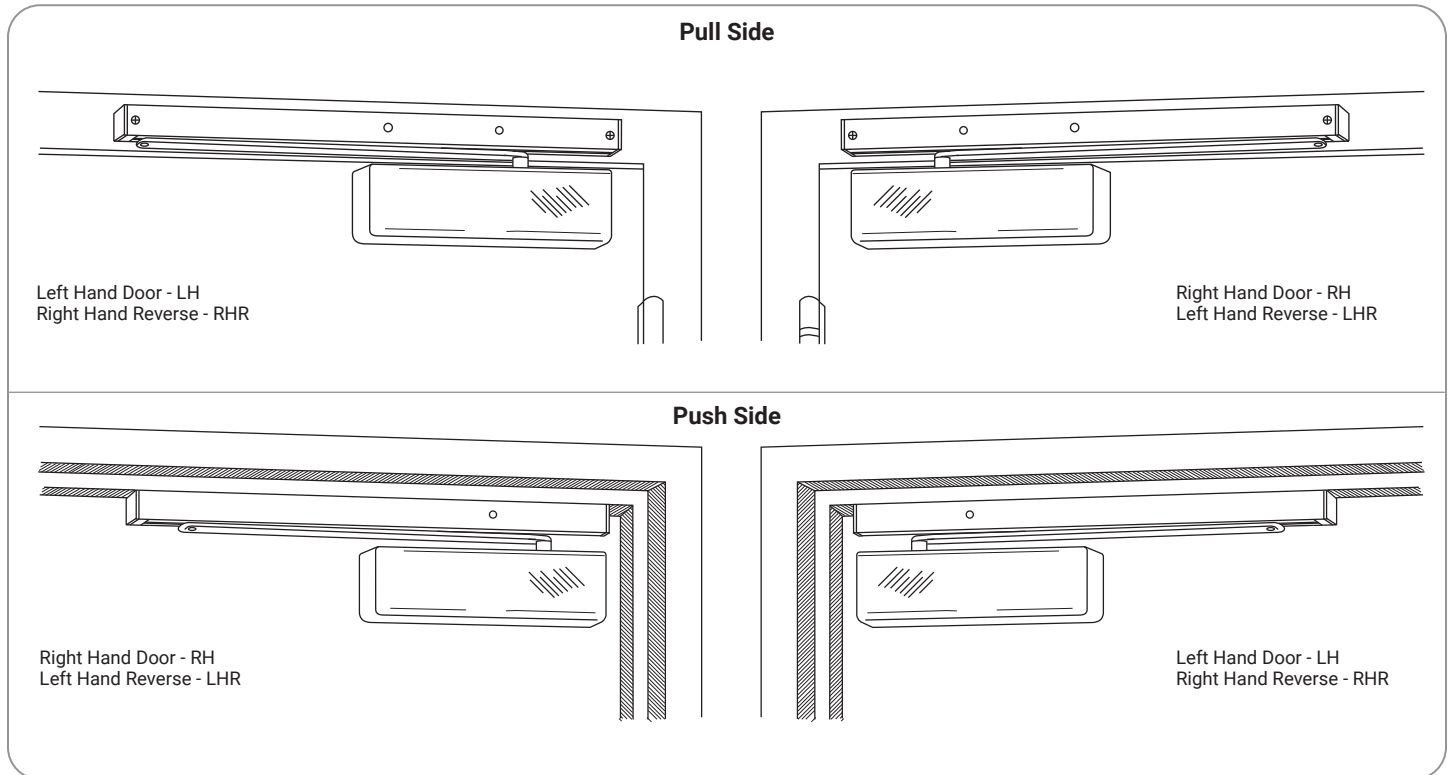

⚠ WARNING

This product can expose you to lead which is known to the state of California to cause cancer and birth defects or other reproductive harm. For more information go to www.P65warnings.ca.gov.

⚠ WARNING

Attention Installer: Any retrofit or other field modification to a fire rated opening can potentially impact the fire rating of the opening, and ASSA ABLOY makes no representations or warranties concerning what such impact may be in any specific situation. When retrofitting any portion of an existing fire-rated opening, or specifying and installing a new fire-rated opening, please consult with a code specialist or local code official (Authority Having Jurisdiction) to ensure compliance with all applicable codes and ratings.

855-557-5078 x 2 • www.accentra-assaabloy.com

Copyright © 1991, 2011, 2024, 2025, ASSA ABLOY Access and Egress Hardware Group, Inc. All rights reserved. Reproduction in whole or in part without the express written permission of ASSA ABLOY Access and Egress Hardware Group, Inc. is prohibited.

80-9344-0510-010 Rev 4 02/25

Experience a safer
and more open world





Approved 2025-02-26

ATTENTION:

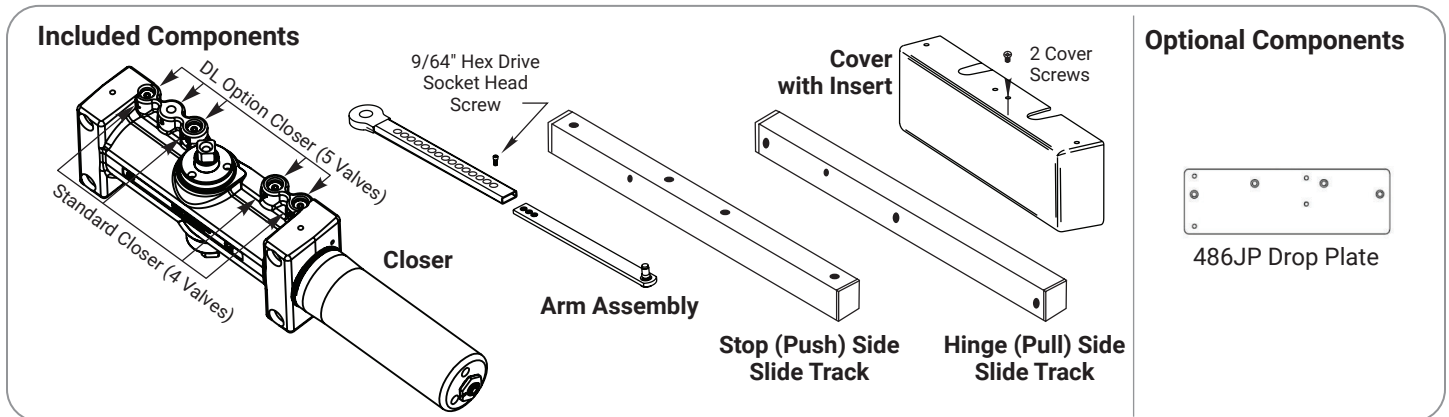
An incorrectly installed or improperly adjusted door closer can cause property damage or personal injury. These installation instructions should be followed to avoid the possibility of misapplication or misadjustment.

- For special applications, a separate door and frame preparation template is packed with these instructions. Use these instructions for installation sequence and closer adjustments only.
- 4400 Series closing force is adjustable from 1-6 as outlined in ANSI Standard A156.4. When closer is adjusted to conform to ADA reduced opening force requirements (5 lbs max.) for interior doors, it may not have adequate closing force to reliably close and latch door. Charted power adjustments in instructions are recommended where possible, to ensure proper door control.
- Adjust closing time speed between 3 - 7 seconds from 90° - 0°.
- These door closers should NOT be installed on exposed side (weather side) of exterior doors.
- Minimum top rail of door with frame stop for PULL Side mount is 3-1/2" (89mm) without drop plate; 2-5/8" (67) with 486JP drop plate. Minimum top rail of door with frame stop for PUSH Side mount is 6" (152mm) without drop plate; 2-5/8" (67) with 486JP drop plate.
- Doors should be hung on ball bearing or anti-friction hinges.
- A separate door stop is recommended.
- Always consult door/frame manufacturer for fastener compatibility.
- Door and frame must be properly reinforced.
- Dimensions are given in inches (millimeters).



Mounting Hardware		Door or Frame	Drill
	Track: 1/4-14 x 1-1/2 Flat Head Self Drilling Screw	Wood	3/16" (4.76mm)
		Aluminum or Metal	no drill required
	Track: 1/4-14 x 3 Flat Head Self Drilling Screw	Wood	3/16" (4.76mm)
		Aluminum or Metal	no drill required
	Track: 1/4-20 x 1-1/2 Oval Head Machine Screw	Metal	Drill #7 (.201 dia. or 5.10mm) Tap 1/4-20
	Closer or Track: Sleeve Nut and Bolt (SNB) (optional)	Hollow Metal	9/32" (7.00mm) thru 3/8" (9.50mm) door face opposite to closer
		Aluminum or Wood	3/8" (9.50mm) thru
	Closer or Track: Thru Bolt and Grommet Nut (TBGN) (optional)	All	9/32" (7.00mm) thru 3/8" (9.50mm) dia. x 3/8" (9.50mm) deep, door face opposite to closer

Pull Side Installation

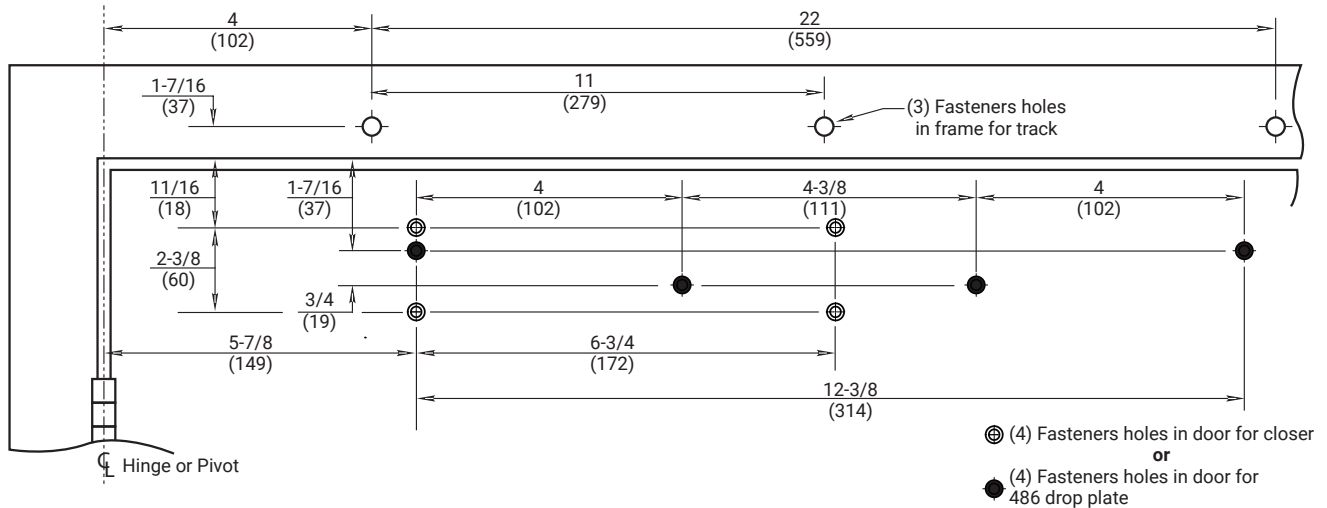

Installation Sequence:

1. Use template to locate holes on door and frame:
 - four (4) on door for closer or drop plate
 - three (3) on frame face for track assembly
2. Prepare door and frame for fasteners using chart on page 2 and set the closer power for door size using chart on page 5.
3. Fasten closer body to door with power adjustment nut toward lock edge of door and with valves UP for Right Hand door valves DOWN for Left Hand door
4. Fasten slide track to frame face with open side facing down and spring buffer end toward hinge edge of door.
5. Adjust arm to shortest length and install 9/64" hex drive socket head screw from screw pack.
6. Place slide arm on pinion shaft using Arm Indexing instructions. (Figure 1)
7. Secure arm with arm washer and arm screw.
8. Insert arm stud into slide block in track assembly. Secure by pushing in on retainer clip that extends from slide block in track, until it is flush with slide block.
9. Install cover (Figure 2) or make adjustments.



IMPORTANT: From centerline of hinge to end of track is 26-1/2" (673mm)

- Right hand door shown
- Do not scale drawing
- Dimensions are given in inches (mm)
- Min. ceiling clearance for unit is 2" (50mm) from frame rabbet:
 - 110° Max. - Non-Hold Open with Spring Buffer
 - 180° Max. - Non-Hold Open without Spring Buffer
 - 110° Max. - Hold Open

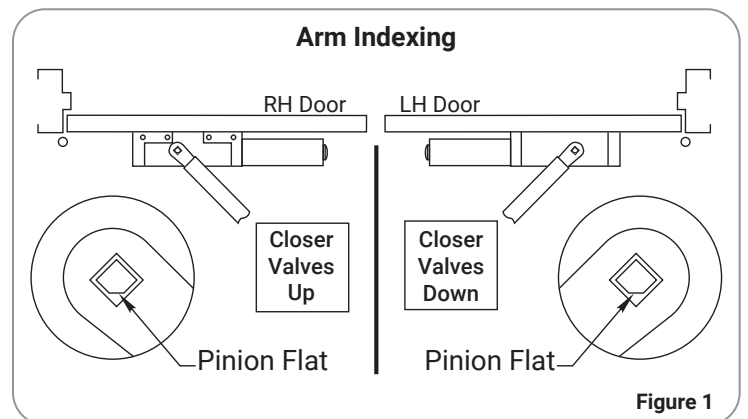

Figure 1

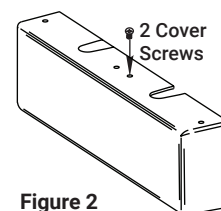
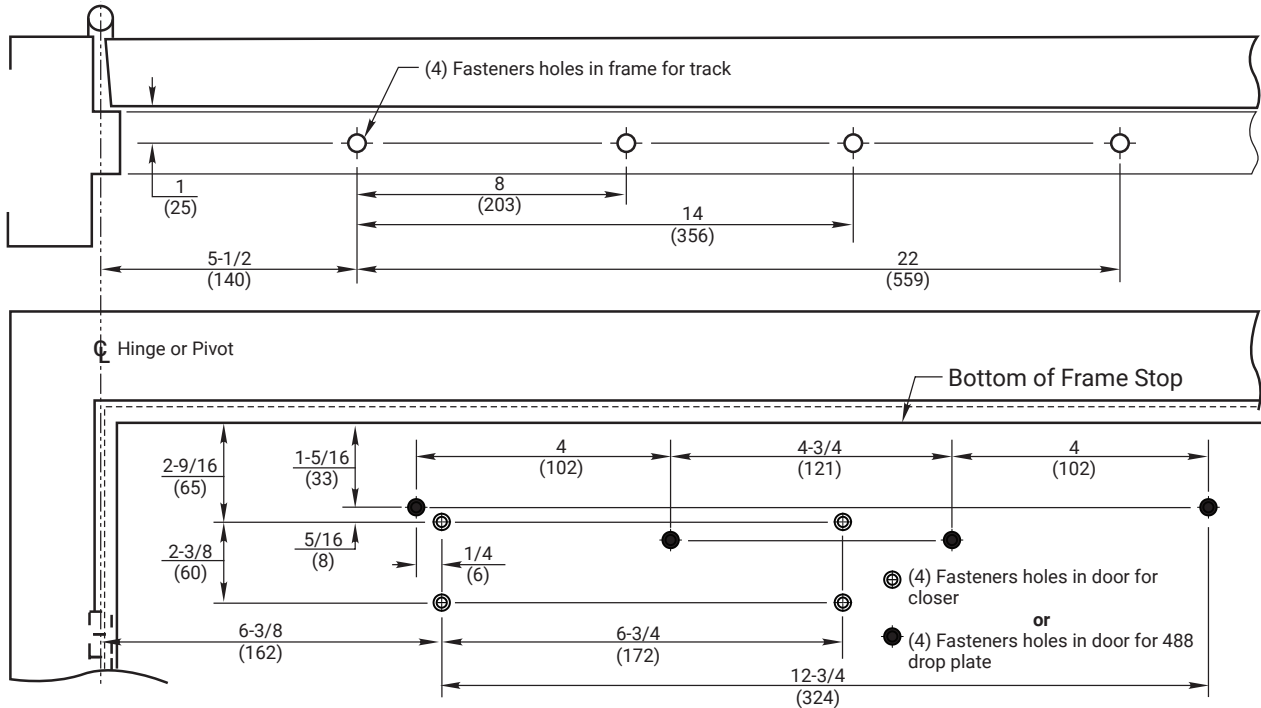

Figure 2

● Go to page 5 for closer adjustments.

Push Side Installation



Installation Sequence:

1. Use template to locate holes on door and frame:
 - four (4) on door for closer or drop plate
 - four (4) on frame soffit for track assembly
2. Prepare door and frame for fasteners using chart on page 2 and set the closer power for door size using chart on page 5.
3. Fasten closer body to door with power adjustment nut toward lock edge of door and with:
 - valves UP for Right Hand door
 - valves DOWN for Left Hand door
4. Fasten slide track to frame soffit with open side facing down and spring buffer end toward hinge edge of door.
5. Adjust arm to shortest length and install 9/64" hex drive socket head screw from screw pack.
6. Place slide arm on pinion shaft using Arm Indexing instructions. (Figure 3)
7. Secure arm with arm washer and arm screw.
8. Insert arm stud into slide block in track assembly. Secure by pushing in on retainer clip that extends from slide block in track, until it is flush with slide block.
9. Install cover (Figure 4) OR make adjustments.



IMPORTANT: From centerline of hinge to end of track is 28" (711mm)

- Left hand door shown
- Do not scale drawing
- Dimensions are given in inches (mm)
- Maximum door opening:
 - 100° Max. - Non-Hold Open with Buffer in Track
 - 125° Max. - Non-Hold Open without Buffer in track; auxiliary door stop required
 - 100° Max. - Hold Open

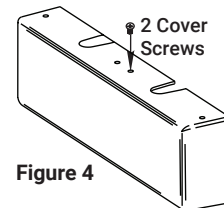
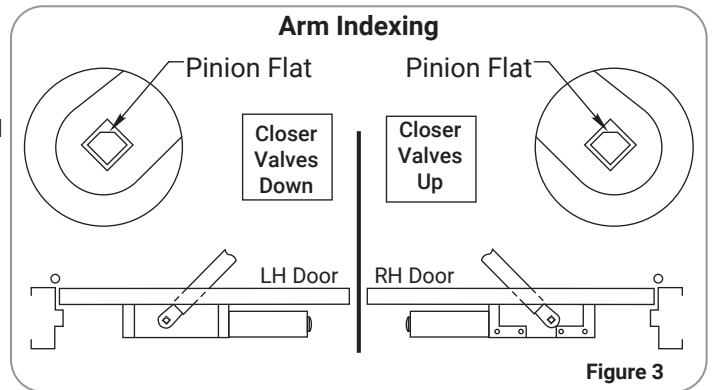

● Go to page 5 for closer adjustments.

Adjustments

Door Stop Angle or Hold Open Angle (Figure 5)

Remove 9/64" hex drive socket head screw from arm. Open door to desired angle and install hex-drive socket head screw into hole in adjusting rod that is aligned with hole in adjusting tube.

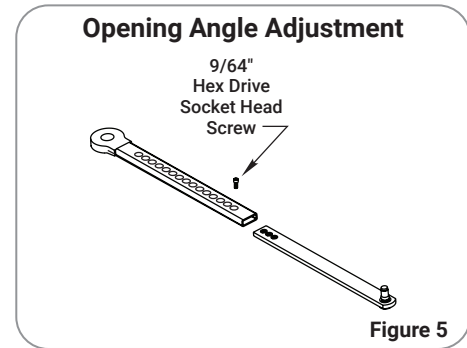

On/Off Hold Open Feature (Figure 6)

Slotted screw, accessible through hole in face of track, engages or disengages hold open feature with 1/4 turn of screw. Hold open units are not permitted in fire door assemblies.

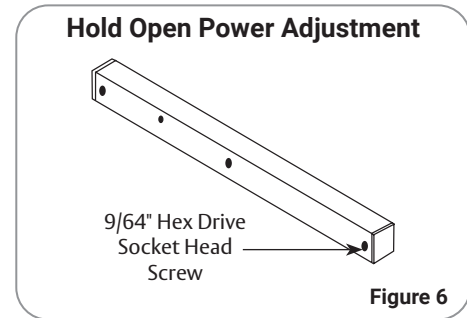

Hold Open Power Adjustment (Figure 6)

If more hold open power is required, power may be increased by turning adjustment screw in end of the track nearest hinges. Use 9/64" hex wrench provided and rotate adjustment screw clockwise to increase holding power.

Closing Power (Figure 7)

4440ST Models are fully adjustable for proper sizing (Figure 7). To adjust closer power, install closer per instructions with proper pre-load applied to arm then adjust spring power.

NOTE: Power adjustment will not work properly if closer spring is not pre-loaded.

Closing Cycle – Hydraulic Control (Figure 8)

Standard Closer Only

- Valve "L" controls door speed in Latch range.
- Valve "S/D" controls door speed in Sweep range.

Delayed Action Closer Only

- Valve "L" controls door speed in Latch range.
- Valve "S" controls door speed in Sweep range.
- Valve "S/D" controls door speed in Delay range.

Opening Cycle – Hydraulic Control (Figure 8)

- Valve "B" cushions (slows) door opening in backcheck range.
- Valve "P" allows "backcheck" to begin later in opening cycle.

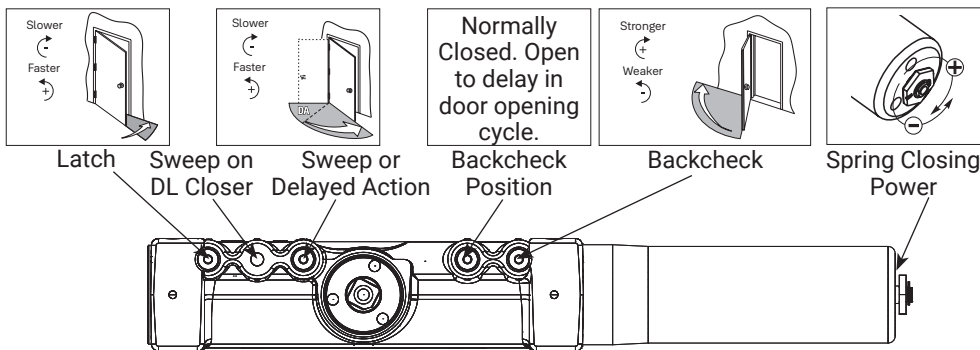

Power Adjustment Chart				
DOOR	Number of Full Clockwise Turns Required			
	MAXIMUM DOOR SIZE			
	30" (76cm)	36" (91cm)	42" (107cm)	48" (122cm)
Interior Door	0	2	5	8
Exterior Door	2	5	8	11

NOTE: Maximum of 16-1/2 turns (360°) of Power Adjustment Nut.

Figure 7

! Use provided hex wrench to turn valves. **NEVER** force valves out of closer. **NEVER** completely close backcheck valve.

Door must be open to adjust spring closing power. **Do not use a power drill.** **Warranty will be void.**

