

# 715 Cylinder Dogging Kit

## Installation Instructions

ACCENTRA

ASSA ABLOY

### Used with 7000 Series Exit Devices

Application: Any Non-Fire rated 7000 Series exit devices (rim, vertical rod, or mortise) shipped after March 1994.

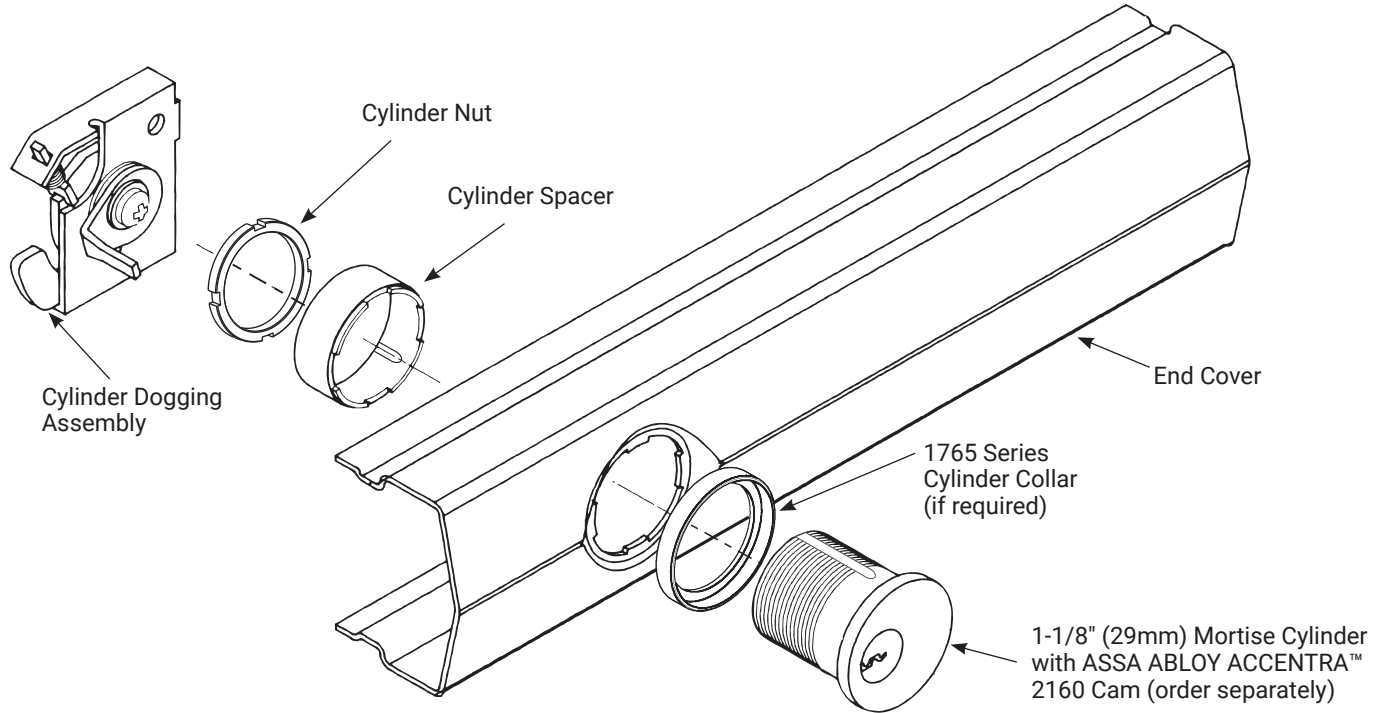

#### Cylinder End Cover Assembly:

1. Position cylinder into end cover with keyway horizontal and plug toward closest end of cover.
2. Engage cylinder spacer lugs into matching notches in end cover.
3. Secure parts in place with cylinder nut.

Dimensions are shown in inches (mm).

**NOTE:** Use ACCENTRA 2153 x 2160 cam, 1-1/8" (29mm) mortise cylinder (order separately). For cylinders over 1-1/8" (29mm), use ACCENTRA 1765 series cylinder ring.

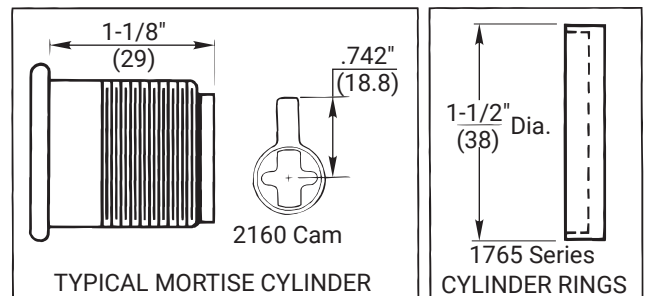

#### **⚠ WARNING**

This product can expose you to lead which is known to the state of California to cause cancer and birth defects or other reproductive harm. For more information go to [www.P65warnings.ca.gov](http://www.P65warnings.ca.gov).

#### **⚠ WARNING**

Attention Installer: Any retrofit or other field modification to a fire rated opening can potentially impact the fire rating of the opening, and ASSA ABLOY makes no representations or warranties concerning what such impact may be in any specific situation. When retrofitting any portion of an existing fire-rated opening, or specifying and installing a new fire-rated opening, please consult with a code specialist or local code official (Authority Having Jurisdiction) to ensure compliance with all applicable codes and ratings.

1-855-557-5078 Ext. 2 • [www.accentra-assaabloy.com](http://www.accentra-assaabloy.com)

80-9470-0715-000 04/24

Copyright © 1994, 2013, 2023, 2024, ASSA ABLOY ACCENTRA™ Access and Egress Hardware Group, Inc. All rights reserved. Reproduction in whole or in part without the express written permission of ASSA ABLOY Access and Egress Hardware Group, Inc. is prohibited.

Experience a safer  
and more open world

## Installation Instructions

1. Assemble cylinder end cover. See other side for cylinder dogging kit components and assembly instructions. **NOTE:** Retain all parts until instructions are complete.

Reference **Figure A** for Steps 2 through 4.

2. Remove end cap from exit device by removing (2) 8-32 X 5/16" (8mm) PFHUMS.
3. Slide end cover off.
4. Remove standard (hex-key) dogging assembly by removing (2) 10-24 x 5/8" (16mm) PPHTSMS.

Reference **Figure B** for Steps 5 through 8.

5. Install cylinder dogging assembly, positioned as shown. Use (2) 10-24 x 5/8" (16mm) screws from standard dogging assembly.
6. Cut new end cover if necessary on end furthest from cylinder hole. Remove black cap from standard end cover. Install black cap in new cylinder end cover (uncut end).
7. Slide end cover assembly in place.
8. Replace end cap from step 2 with (2) 8-32 X 5/16" (8mm) PFHUMS.
9. Check cylinder dogging action.
  - a. To engage, fully depress touchbar, turn dogging cylinder key clockwise (latchbolt should be fully retracted and touchbar should remain fully depressed).
  - b. To disengage, turn dogging key counterclockwise, while keeping touchbar fully depressed (touchbar and latchbolt should become active).

# ACCENTRA

# ASSA ABLOY

**FIGURE A: DEVICE WITH STANDARD DOGGING**

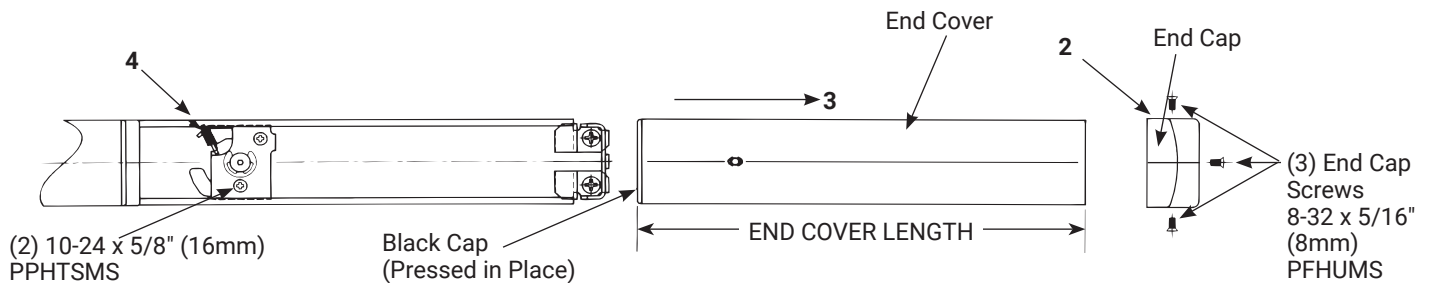

**FIGURE B: DEVICE WITH CYLINDER DOGGING**

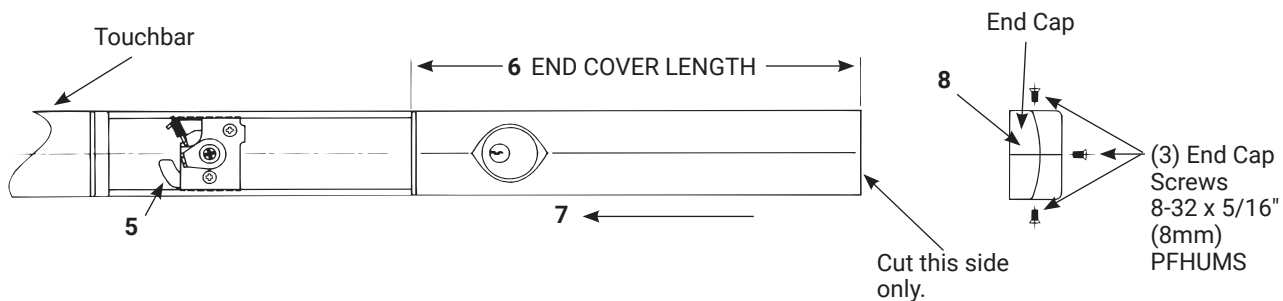

Installation in any Fire Exit Device (7100F and 7200MF Series) is prohibited, and violates national, local life safety, and building codes. Application to fire labeled exit devices cancels the Underwriters Laboratories label.

ABBREVIATION	FASTENER DESCRIPTION
PFHUMS	Phillips Flat Head Under Cut Machine Screw
PPHTSMS	Phillips Pan Head Type t Sheet Metal Screw

80-9470-0715-000 04/24

1-855-557-5078 Ext. 2 • [www.accentra-assaabloy.com](http://www.accentra-assaabloy.com)

Copyright © 1994, 2013, 2023, 2024, ASSA ABLOY ACCENTRA™ Access and Egress Hardware Group, Inc. All rights reserved. Reproduction in whole or in part without the express written permission of ASSA ABLOY Access and Egress Hardware Group, Inc. is prohibited.

Experience a safer  
and more open world