

791 STRIKE DETAIL

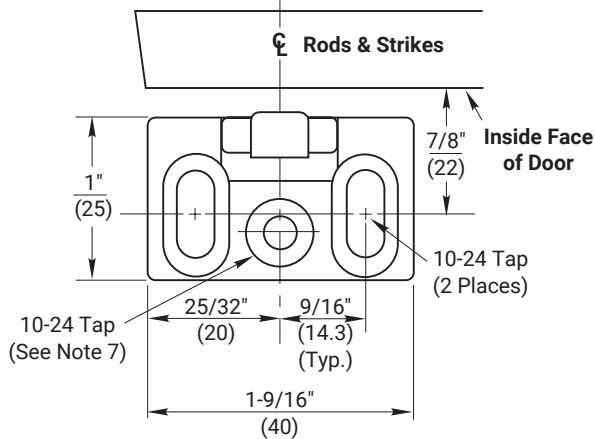

NOTES:

1. Do not scale drawing.
2. Dimensions are in inches (mm).
3. LHR door shown. Preparation is typical for both door hands.
4. Minimum door stile width 4-1/2" (114).
5. Prepare mounting holes when installing device.
6. Unreinforced frames require blind rivet nuts (by others) to mount the strike.
7. This hole **MUST** be field located using physical part as template, after installation is complete and device is fully operational.
8. Provide adequate structural support to maintain door integrity after device installation with power tools, door use, or abuse.
9. Device mount to hinge stile (not shown) requires hole location and preparation during device installation. Door structural requirements to support the device cases are similar for both door stiles.
10. For outside trim preparation see appropriate trim template.
11. Cutout, 1/2" (13) deep, only required when outside trim is used.
12. Wood screws #14 x 1-1/2" (by others) permitted in solid core wood doors, if pilot holes are used for installation, when door label allows its use.

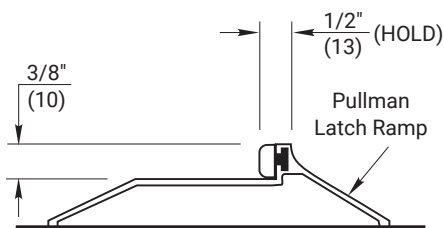

PANIC TYPE LATCHING THRESHOLD TYPICAL DETAIL

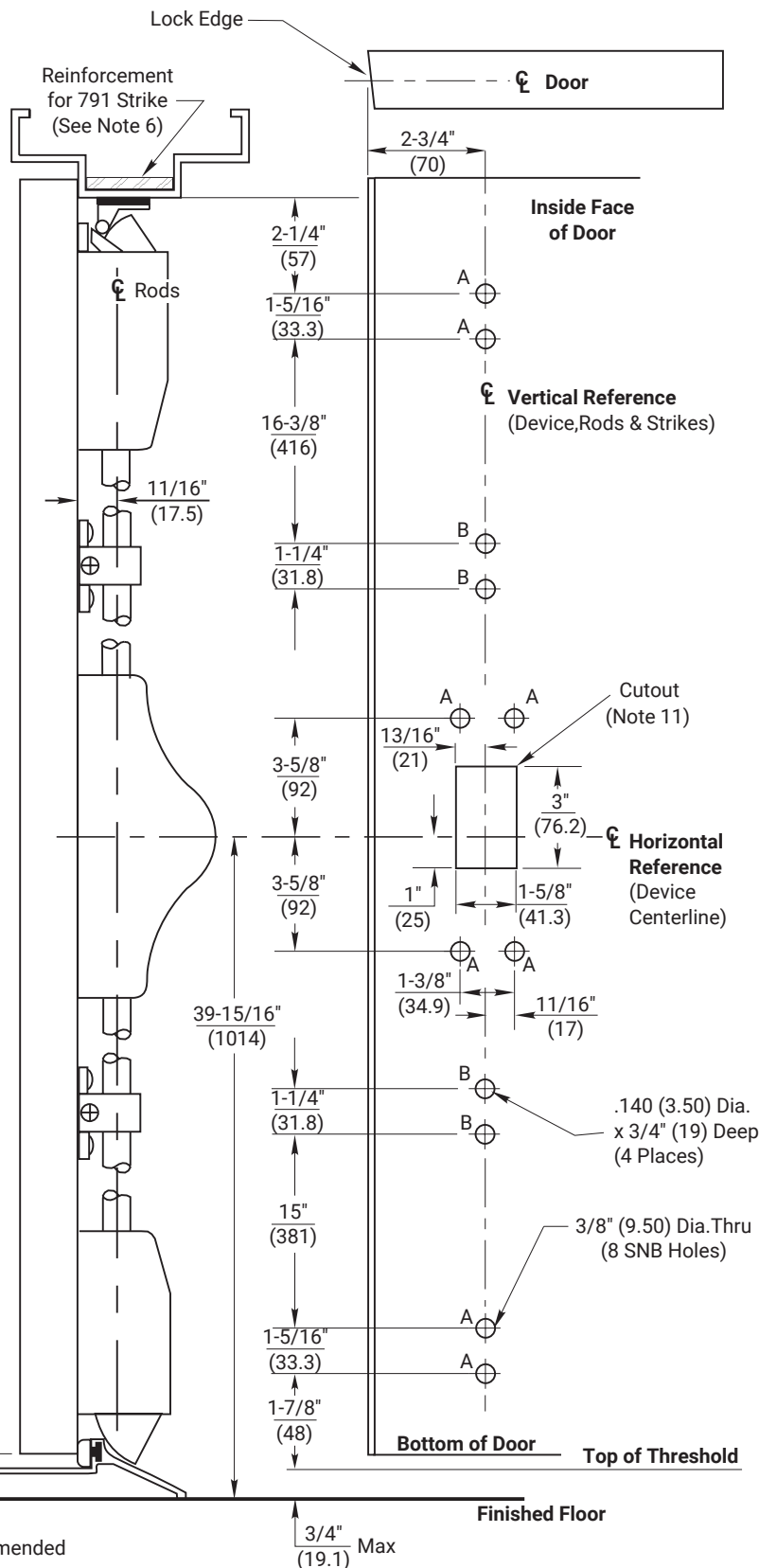

RESPONSIBILITY
 DOOR AND FRAME MANUFACTURERS ARE RESPONSIBLE FOR PROVIDING ADEQUATE CONSTRUCTION OR REINFORCEMENTS FOR PROPER INSTALLATION OF HARDWARE SHOWN. ALL ARCHITECTURAL BUILDERS HARDWARE MUST BE INSTALLED ON PROPERLY REINFORCED DOORS AND FRAMES, REGARDLESS OF TYPE, MATERIAL, OR METHOD OF CONSTRUCTION.

1510 Surface Vertical Rod Panic Devices with Bottom Pullman Latch Option and SNB
 Application for Wood or Composite Door and H.M. Frame with Latching Threshold
 1-855-557-5078 Ext. 2
www.accentra-assaabloy.com

ACCENTRA
ASSA ABLOY

Experience a safer and more open world

Copyright © 1999, 2023, 2024, ASSA ABLOY Access and Egress Hardware Group, Inc. All rights reserved. Reproduction in whole or in part without the express written permission of ASSA ABLOY Access and Egress Hardware Group, Inc. is prohibited.

SUPERSEDES 7415-1016 (12/23)	DO NOT SCALE DRAWING	
TEMPLATE NUMBER 7415-1016	SHEET 1 of 1	DATE 07/24