

FRAME APPLICATIONS

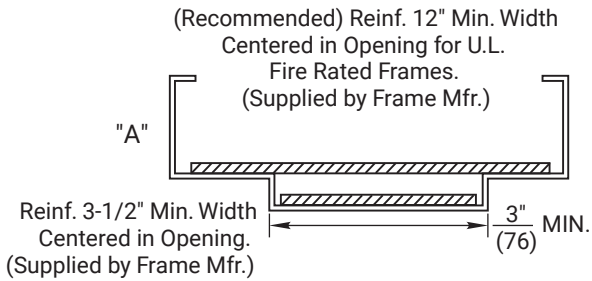

Recommended for double rabbeted frames where stop face is less than 3" (76) wide.

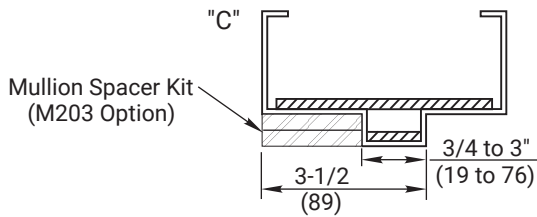

SOFFIT PREP (TOP VIEW)
—TYPICAL FOR ALL FRAMES—

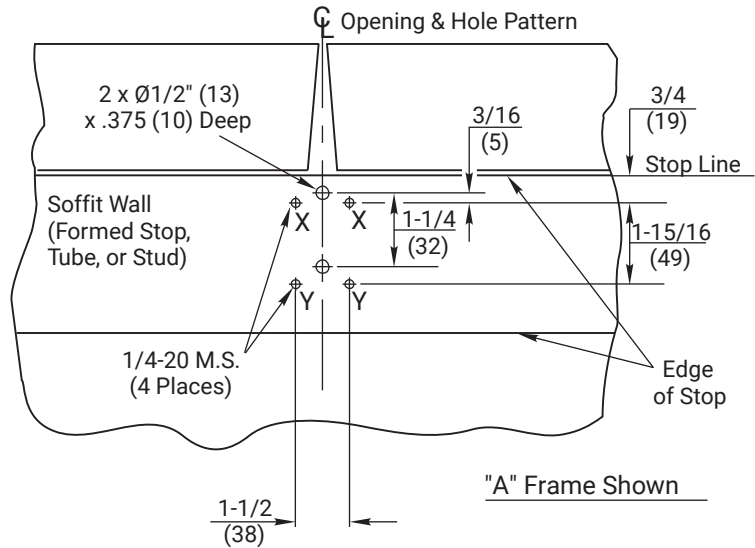

Application	Holes Required
"A"	X & Y
"C"	X & Y (Note 5)

Notes:

1. Do not scale drawing. Dimensions shown in inches(mm).
2. Prepare mounting holes when installing the mullion. Use this template for structural frame preparation.
3. Metal frames should provide mounts to maintain not less than (3) full screw threads engaged.
4. M200FWS and KRM200FWS mullions are made from 2" x 3" (51 x 76) tubular steel. Locate device from mullion face (strike seat).
5. Two flat head 1/4-20 x 1-1/4 machine screws are included with Mullion Spacer Kit (M203 Option) when so ordered.

RESPONSIBILITY

DOOR AND FRAME MANUFACTURERS ARE RESPONSIBLE FOR PROVIDING ADEQUATE CONSTRUCTION OR REINFORCEMENTS FOR PROPER INSTALLATION OF HARDWARE SHOWN. ALL ARCHITECTURAL BUILDERS HARDWARE MUST BE INSTALLED ON PROPERLY REINFORCED DOORS AND FRAMES, REGARDLESS OF TYPE, MATERIAL, OR METHOD OF CONSTRUCTION.

**KRM200(F) & M200(F) Mullions
Frame Preparation**

1-855-557-5078 Ext. 2
www.accentra-assaabloy.com

ACCENTRA
ASSA ABLOY

Experience a safer
and more open world

Copyright ©2024, ASSA ABLOY ACCENTRA™ Access and Egress Hardware Group, Inc. All rights reserved. Reproduction in whole or in part without the express written permission of ASSA ABLOY Access and Egress Hardware Group, Inc. is prohibited.

SUPERSEDES 7400-0210 02/24	DO NOT SCALE DRAWING	
TEMPLATE NUMBER 7400-0210	SHEET 1 of 1	DATE 04/24