

Notes:

1. This template is an addition to the device template. Locate centerlines using horizontal and vertical references on device template.
2. Do not scale drawing
3. Dimensions are in inches (mm).
4. LHR door shown. Preparation is typical for both door hands.
5. For door reinforcement see template 7400-0000.
6. Prepare mounting holes when installing the trim.
7. Provide adequate internal support to prevent door deformation after trim is bolted to the device.

Hole	Specification
A	3/8(9.50) Dia. Outside Face 5/16(8) Dia. Inside Face (3 Places)
B	3/8(9.50) Dia. Outside Face

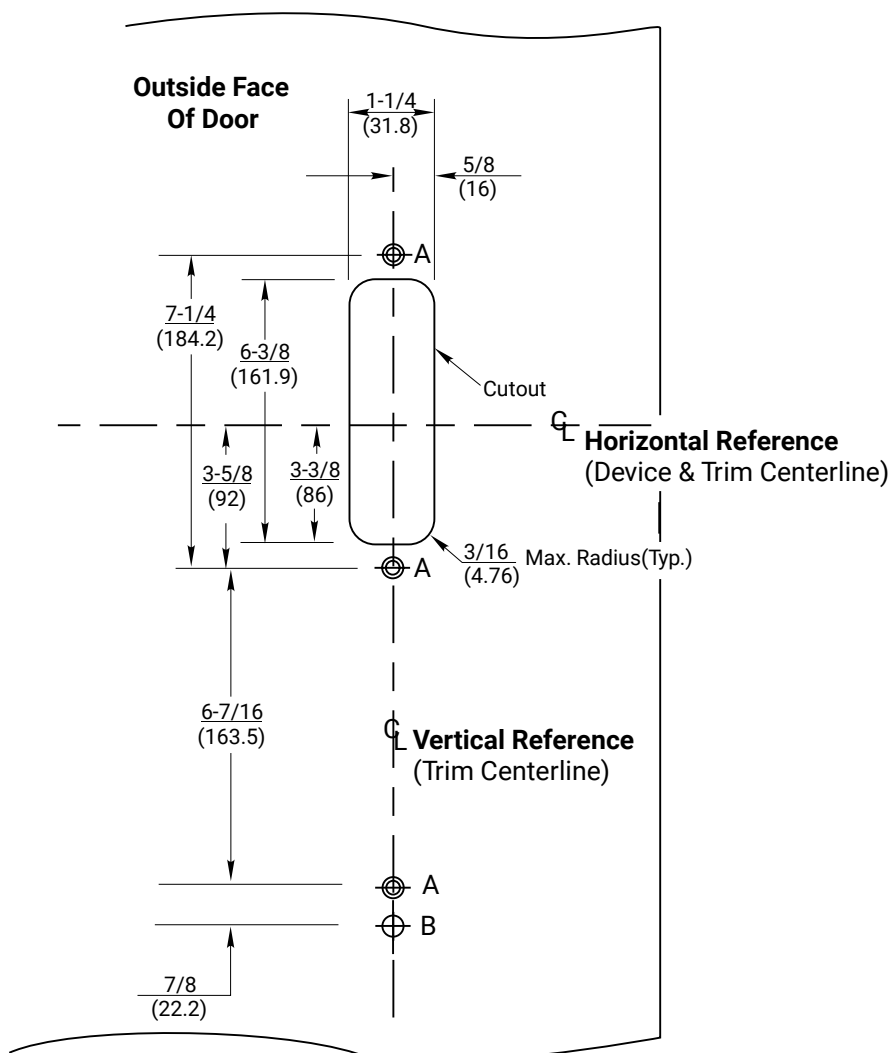
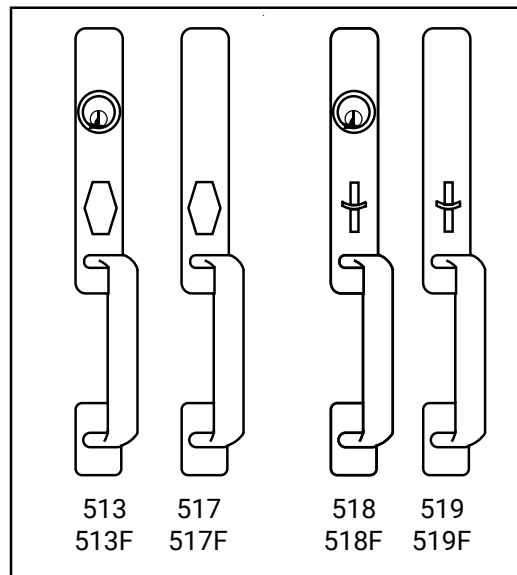

**RESPONSIBILITY**  
 DOOR AND FRAME MANUFACTURERS ARE RESPONSIBLE FOR PROVIDING ADEQUATE CONSTRUCTION OR REINFORCEMENTS FOR PROPER INSTALLATION OF HARDWARE SHOWN. ALL ARCHITECTURAL BUILDERS HARDWARE MUST BE INSTALLED ON PROPERLY REINFORCED DOORS AND FRAMES, REGARDLESS OF TYPE, MATERIAL, OR METHOD OF CONSTRUCTION.

**514(F) Narrow Escutcheon Trim**  
 With 7200, 7200M or 7200MF Series  
 Rim and Vertical Rod Exit Devices  
 Metal Door Preparation  
 1-855-557-5078 Ext. 2  
[www.accentra-assaabloy.com](http://www.accentra-assaabloy.com)

**ACCENTRA**  
**ASSA ABLOY**

Experience a safer  
 and more open world

Copyright ©2024, ASSA ABLOY ACCENTRA™ Access and Egress Hardware Group, Inc. All rights reserved. Reproduction in whole or in part without the express written permission of ASSA ABLOY Access and Egress Hardware Group, Inc. is prohibited.

SUPERSEDES	7400-0514 02/24	DO NOT SCALE DRAWING	
TEMPLATE NUMBER	7400-0514	SHEET	DATE
		1 of 1	04/24