

Notes:

1. This template is an addition to the device template. Locate centerlines using horizontal and vertical references on device template.
2. Do not scale drawing.
3. Dimensions are in inches (mm).
4. LHR door shown. Preparation is typical for both door hands.
5. For door reinforcement see template 7400-0000.
6. Prepare mounting holes when installing trim.
7. Provide adequate internal support to prevent door deformation after trim is bolted to the device.

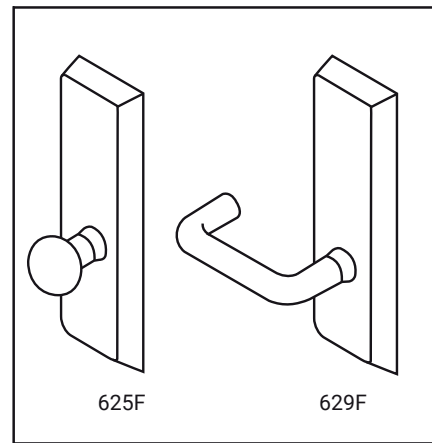

Note: Lever and knob prefix does not affect door prep.

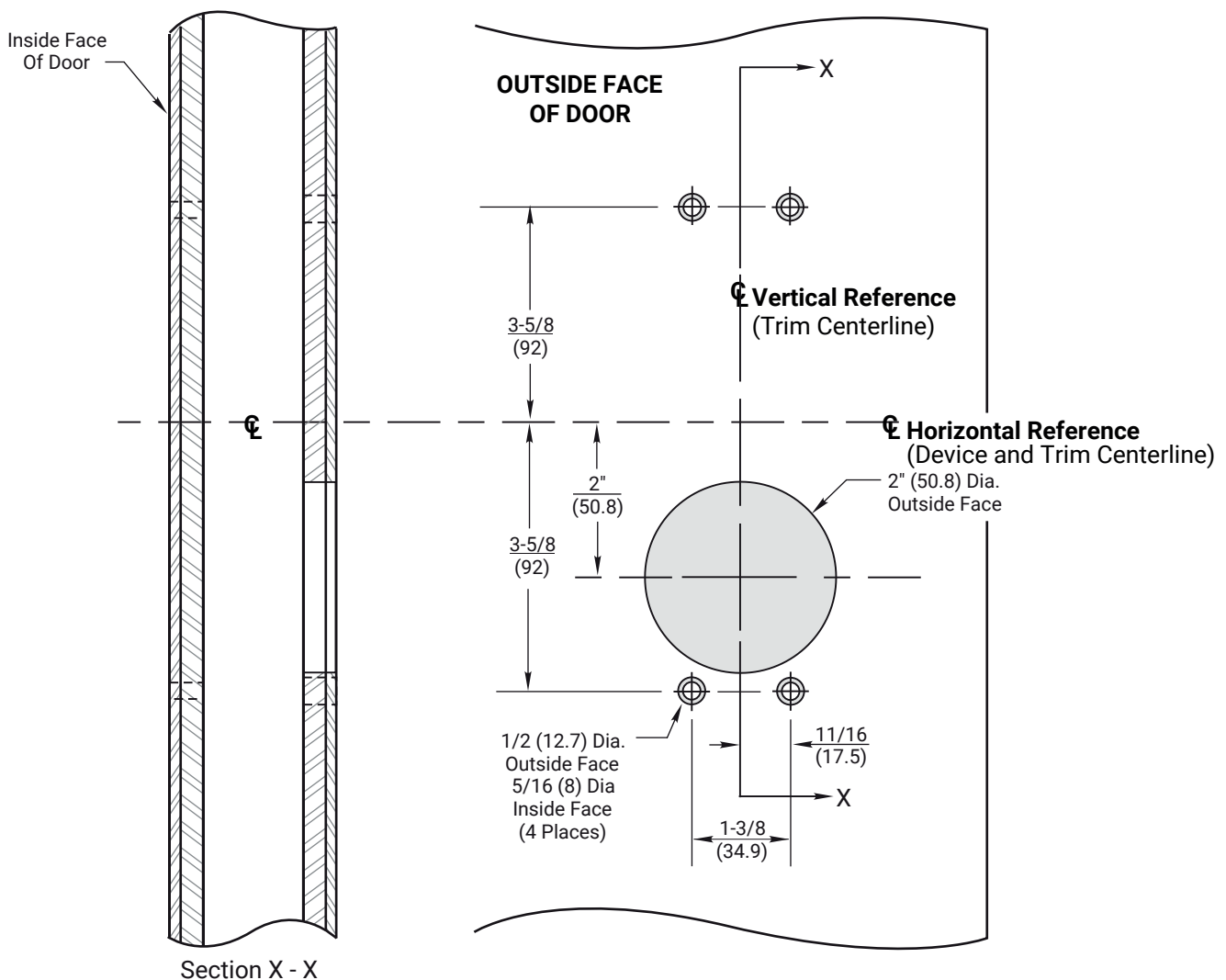

RESPONSIBILITY
 DOOR AND FRAME MANUFACTURERS ARE RESPONSIBLE FOR PROVIDING ADEQUATE CONSTRUCTION OR REINFORCEMENTS FOR PROPER INSTALLATION OF HARDWARE SHOWN. ALL ARCHITECTURAL BUILDERS HARDWARE MUST BE INSTALLED ON PROPERLY REINFORCED DOORS AND FRAMES, REGARDLESS OF TYPE, MATERIAL, OR METHOD OF CONSTRUCTION.

625F and 629F Trim
 With 1500(F), 2100(F), 6100(F) or 7100(F) Series
 Rim and Vertical Rod Exit Devices
Metal Door Preparation
 1-855-557-5078 Ext. 2
www.accentra-assaabloy.com

ACCENTRA
ASSA ABLOY

Experience a safer
 and more open world

Copyright © 2006, 2015, 2024, ASSA ABLOY Access and Egress Hardware Group, Inc. All rights reserved. Reproduction in whole or in part without the express written permission of ASSA ABLOY Access and Egress Hardware Group, Inc. is prohibited.

SUPERSEDES	05/15	DO NOT SCALE DRAWING	
TEMPLATE NUMBER	7400-0625	SHEET	DATE
		1 of 1	05-24