

Notes:

1. Do not scale drawing
2. For strike preparation refer to:
495 Strike - Template No. 7102-0005
497 Strike - Template No. 7102-0003
3. The 5400LN locks can be installed on 1-3/8 " (35mm) thick doors by using two (2) #14-5401-6644-200 spacers under the inside and outside roses.
4. Backset: 2-3/4" (70mm) standard
3-3/4" (95mm) to order
5" (127mm) to order
5. For wood door preparation refer to Template No. 7150-8007
6. Door manufacturer must provide supports within the door to keep the door from collapsing when lock is installed. Back of latch case must also be supported.
7. All dimensions given in inches (mm).
8. Provide 3/4" (19) raceway for wire harness to electric hinge, location optional by door manufacture.

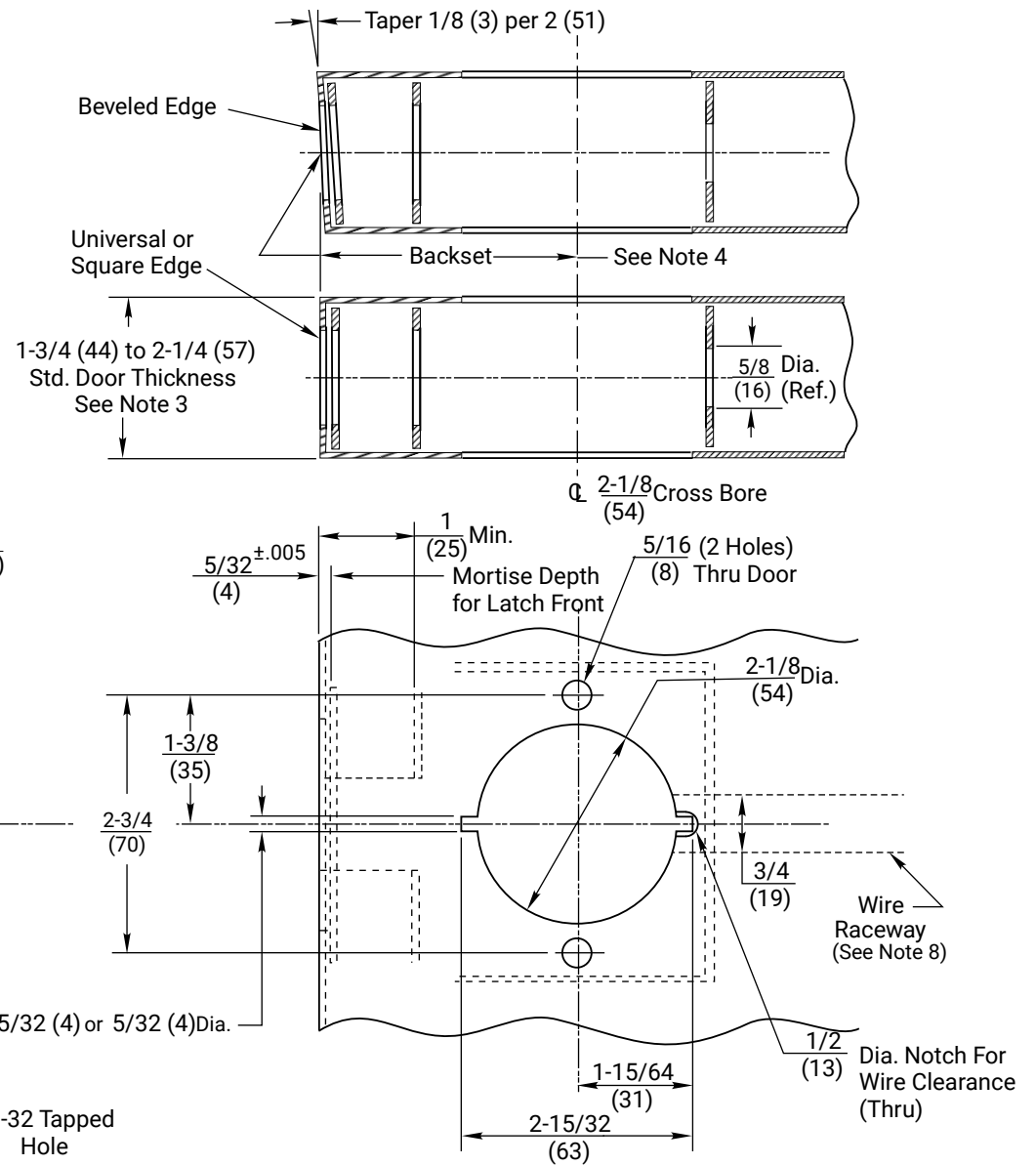

Experience a safer and more open world

Copyright © 2005, 2023, 2024, ASSA ABLOY Access and Egress Hardware Group, Inc. All rights reserved. Reproduction in whole or in part without the express written permission of ASSA ABLOY Access and Egress Hardware Group, Inc. is prohibited.

5480LN, 5481LN, 5490LN, and 5491LN Electric Locks (Lever Handle Trim) H.M. Door Preparation
Backset - 2-3/4" (70mm), 3-3/4" (95mm) and
1-855-557-5078 Ext. 2 www.accentra-assaabloy.com

Template Number:
7150-8006
 Date: 05/24
 Sheet: 1 of 1

ACCENTRA
ASSA ABLOY