

DO NOT SCALE

Notes:

1. Tolerances shown are for cutouts. All dimensions given about centerlines must be central within tolerance unless otherwise specified.
2. All dimensions given in inches (mm).
3. For Sectional Trim see template 7086-1001.
For Thru Bolted Escutcheon Trim see template 7086-1201.
For Surface Applied Escutcheon Trim see template 7086-1301.

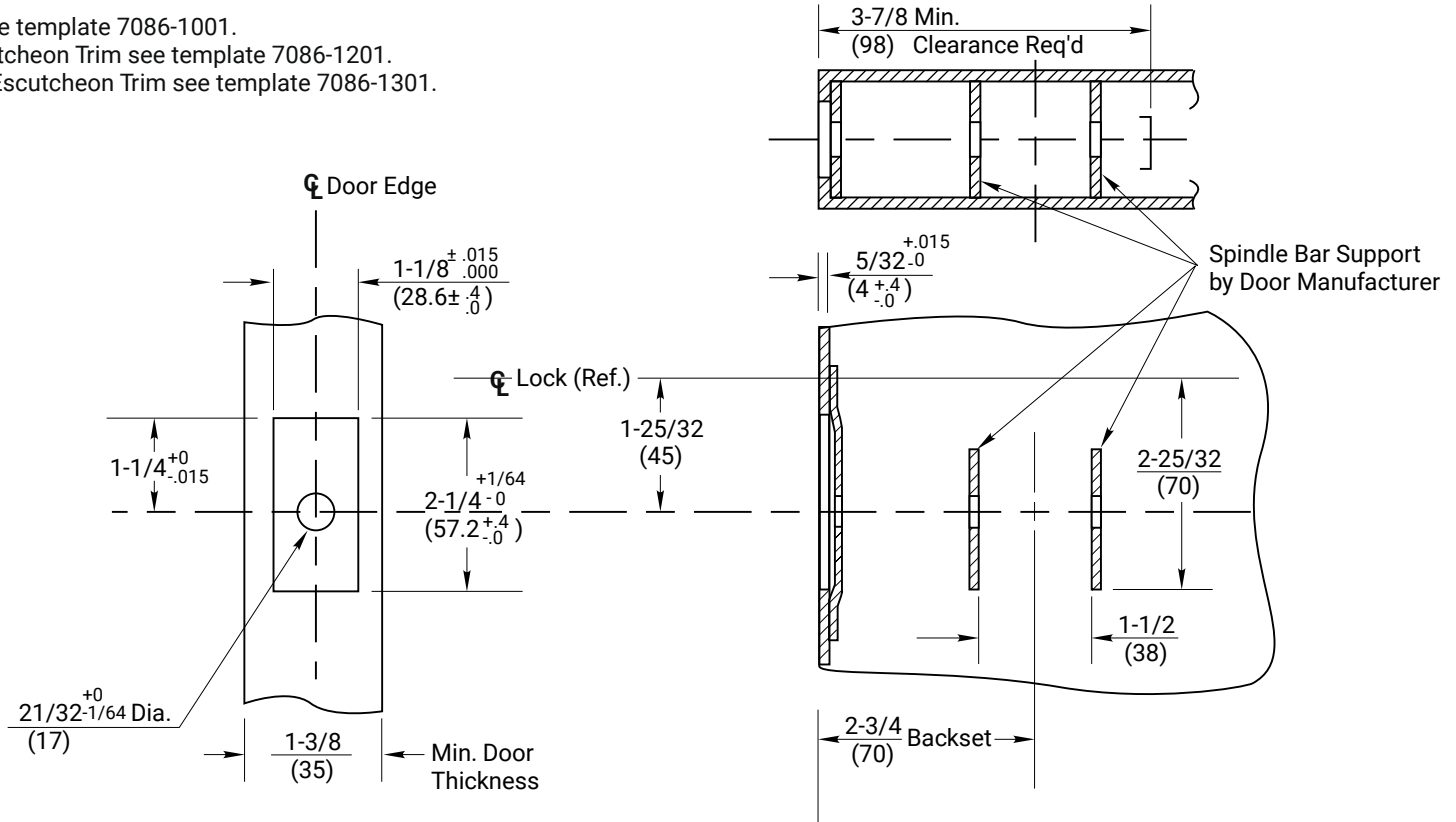

Experience a safer
and more open world

Copyright © 2004, 2024, ASSA ABLOY ACCENTRA™ Access and Egress Hardware Group, Inc. All rights reserved. Reproduction in whole or in part without the express written permission of ASSA ABLOY Access and Egress Hardware Group, Inc. is prohibited.

All Series Mortise Locks
H.M. Door Preparation
836A & 838A Dummy Trim Both Sides (Plain Front)
1-855-557-5078 Ext. 2 www.accentra-assaabloy.com

Template Number:
7086-0007
Date: 04/24
Sheet: 1 of 1

ACCENTRA
ASSA ABLOY