

# ASSA ABLOY Bullet Resistance Level 4-8

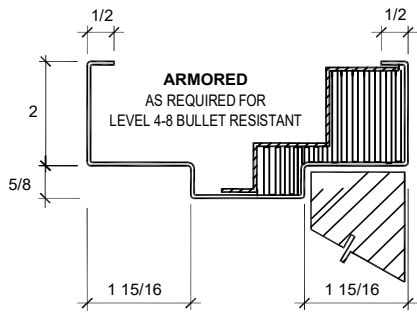

**BULLET LEVEL 4-8 FRAME PROFILE**

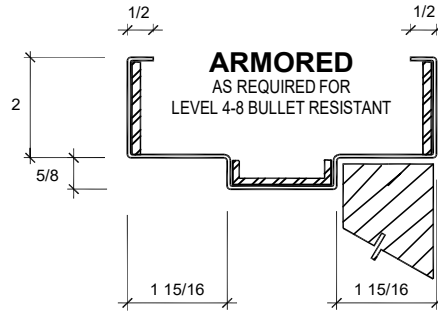

**BULLET LEVEL 4-8 FRAME PROFILE**

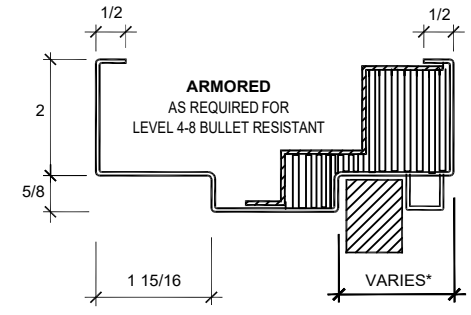

**BULLET LEVEL 4-8 LITE PROFILE**

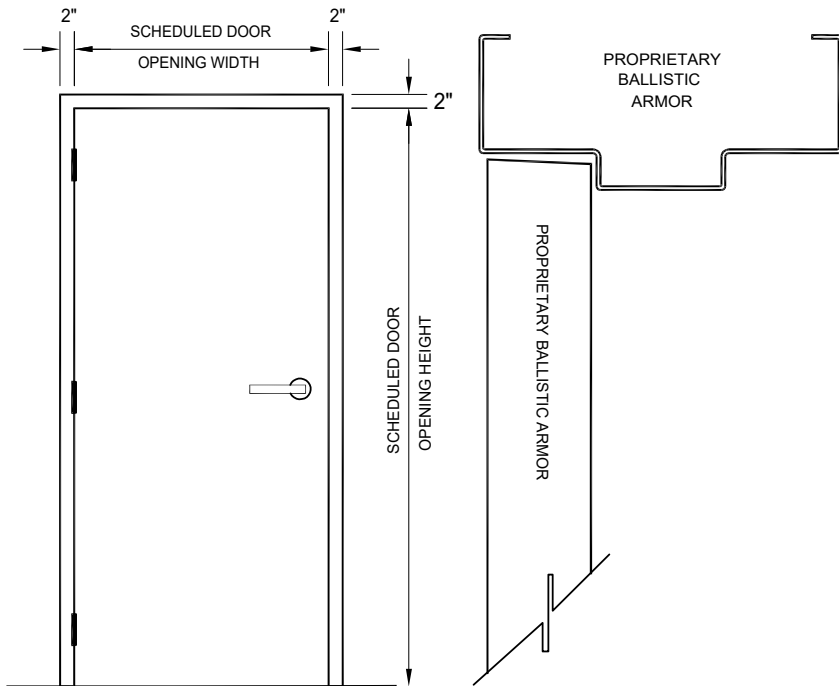

## Specifications:

- All exposed surfaces of door and frame to receive one coat of rust inhibitive prime paint.
- Assembly is equipped with hollow metal door, frame, and created for shipment.
- Nominal door thickness is 1 3/4".
- Door weight is 26.75 pounds per square foot.
- Doors are 14 gauge steel face sheets.
- Frames are 14 gauge steel.
- Special frame profile and anchor types are required.
- Door edges are to be welded and finished smooth.
- Visions available up to full glass. Vision kits vary between Levels 4-8.
  - Minimum top rail 8.5"
  - Minimum bottom rail 12"
  - Minimum hinge and lock stile 8.5"
- Available in conjunction with sound, stainless steel, blast, and lead lined options.
- Frame profile minimum jamb depth:
  - Single rabbet 3.75"
  - Double rabbet 5.75"
- Fire ratings not available
- Max size = 4'0" x 8'0"

## Recommended Hardware Preparation

Lock: Grade A Mortised Lock, Rim Device, or Surface Rod  
Hinge: Markar FS3501, FS3502, HG3505

Heavy duty door closer's recommended.  
For additional hardware consult with manufacturer.

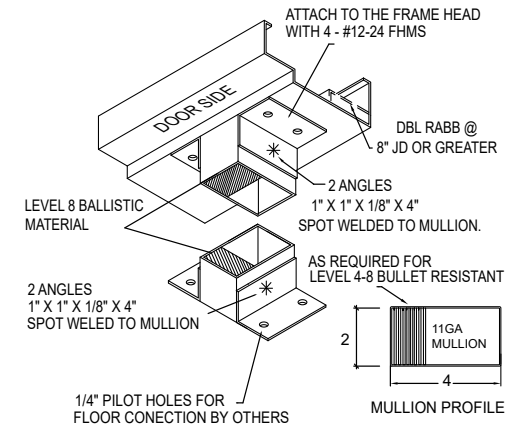

## C76 BULLET RESISTANT LEVEL 4-8 REMOVABLE MULLION

● = PLUG WELD  
99 = 2" GLASS / 2 1/8" GAP (GLAZING CODE)  
MIN. 1/2" TOTAL GLASS "BITE" ON ALL SIDES.  
1/16" WET GLAZED ON BOTH SIDES W/DOW CORNING 995 WET SILICONE (NOT EXPIRED)

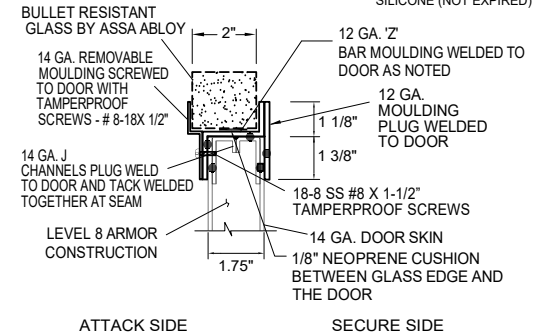

## BULLET LEVEL 8 VISION MOULDING AT NON-FIRE RATED ONLY

Experience a safer  
and more open world

Rating	Ammunition	Grain	(G)	Velocity (FPS)	Velocity (MPS)	No. of Shots
UL Level 4	.30 Caliber Rifle Lead Core Soft Point	180	11.70	2540	774	1
UL Level 5	7.62mm Rifle Lead Core FMJ Military Ball	150	9.70	2750	838	1
UL Level 6	9mm FMJ with Lead Core	124	8	1400	427	5
UL Level 7	5.56 Rifle Lead Core FMJ	55	3.56	3080	939	5
UL Level 8	7.62mm Rifle Lead Core FMJ Military Ball	150	9.70	2750	838	5