

ASSA ABLOY Model AS52C - Acoustical Door System

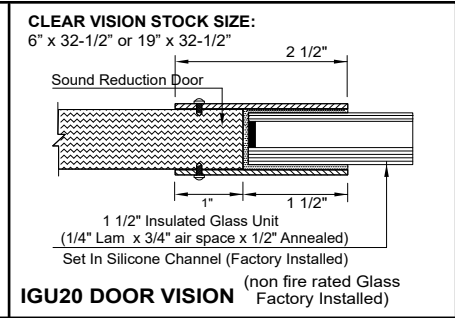

MODEL AS52C UTILIZES "ADJ" PROFILE FRAME (SEAL SET RCG FOR SINGLES, RCGP FOR PAIRS)

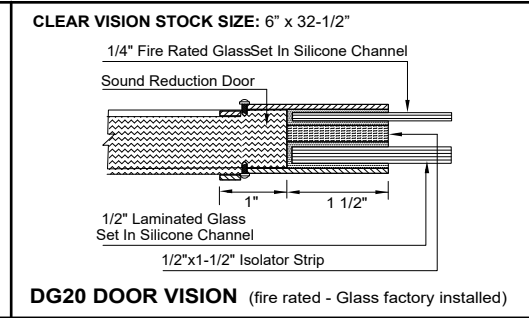
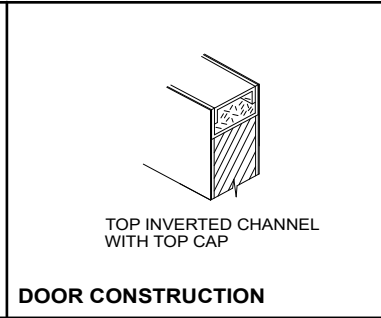
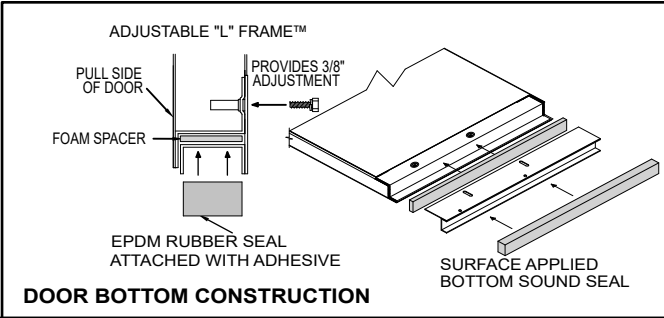
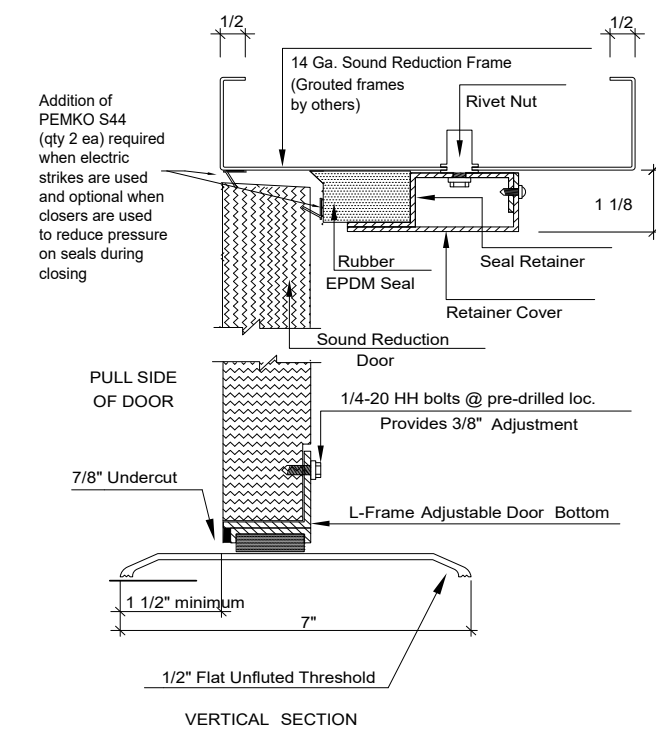

SPECIFICATIONS

- 1) All exposed surfaces of door and frame to receive one coat of rust inhibitive prime paint complying with ASTM A250.10.
- 2) An aluminum threshold is included. Threshold must protrude 1 1/2" inches past the face of the frame on the pull side of the door to allow the EPDM rubber section of the door bottom to seat properly during normal operation of the Gravity-Glide cam-lift hinges.
- 3) Door bottom requires a flush level sealing surface. The threshold must be level and may require shimming to compensate for an uneven floor. This will prevent any sound leaks at this location. Threshold to be grouted solid.
- 4) Assembly is equipped with metal sound door, frame, seals, door bottom, threshold, Gravity Glide cam - lift hinges and crated for shipment.
- 5) Door Thickness is 1 3/4". Door weight is 11.9 pounds per square foot. Be aware that the frame must be securely tied to the framing from the sub floor to the structure above. Doubled wood studs or 16 Ga. steel studs are strongly recommended to support the weight of the assembly.
- 6) Doors are to be formed of no less than 16 Gauge steel face sheets welded at the vertical edges and finished smooth. (14 or 12 gauge also available).
- 7) Frames are to be formed of no less than 14 Gauge sheet steel with corners mitered, continuously welded and ground smooth. (12 gauge also available).
- 8) Doors and frames are formed from commercial quality zinc coated steel conforming to ASTM A653 & ASTM A924. Acoustical core and internal construction are manufacturer's proprietary standards as tested in accordance with ASTM E90, E413, E1332, & E2235.
- 10) Please be aware industry standard construction tolerances for squareness of frame installation, plumbness of walls, flatness of floors, etc. may result in a difference of 3db-5db sound loss in a field test vs. lab results.
- 11) Plastic laminate veneer options available upon request.
- 12) Fire Rated up to 180 minutes.
- 13) Meets SCIF Sound Group 3 and 4.

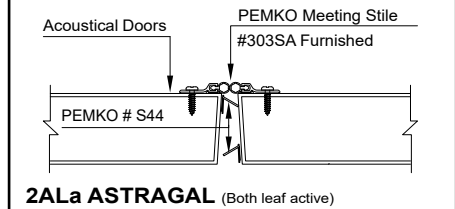
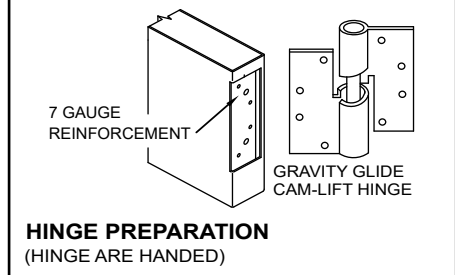
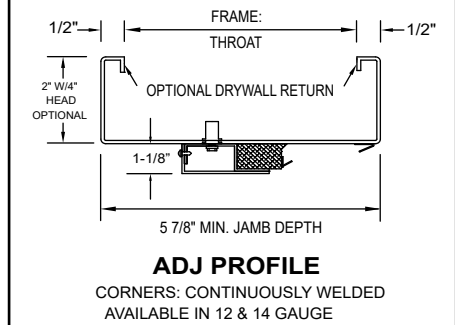

Compression seal system STC50-52 1 3/4" Acoustical Door System Tech. Data

Experience a safer and more open world

FINISH:	STANDARD PRIMER PAINT; TESTED IN CONFORMANCE WITH ANSI A250.10
ACOUSTICAL PERFORMANCE	DOOR SYSTEM TESTED IN CONFORMANCE WITH ASTM E2235, ASTM E1332, ASTM E90 & E413, FULLY OPERABLE, STC AS NOTED ABOVE. DOOR SYSTEMS ARE IN COMPLIANCE WITH HMMMA 865 & SDI-128 SPECIFICATIONS.

- TESTED HDWE PREPS:
- HINGES:**
- GRAVITY GLIDE CAM-LIFT HINGES PROVIDED WITH DOOR AND FRAME LOCK.
 - CYLINDRICAL LOCK ANSI A115.2 3-3/4" BACKSET

