

ASSA ABLOY Model ASE48P - Acoustical Door System

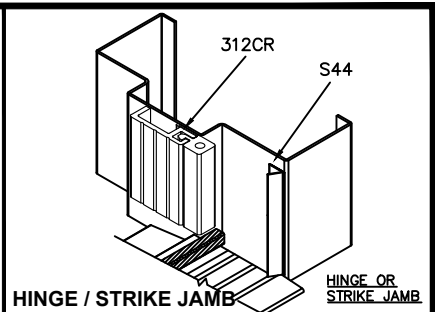

MODEL ASE48P UTILIZES "S" PROFILE FRAME (Pemko seal set 2 for)

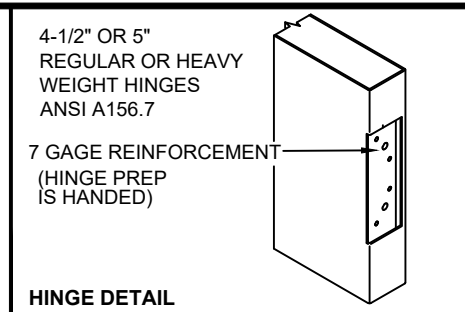
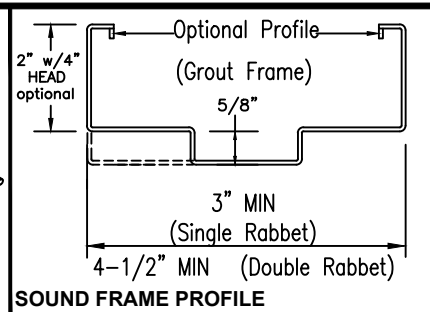
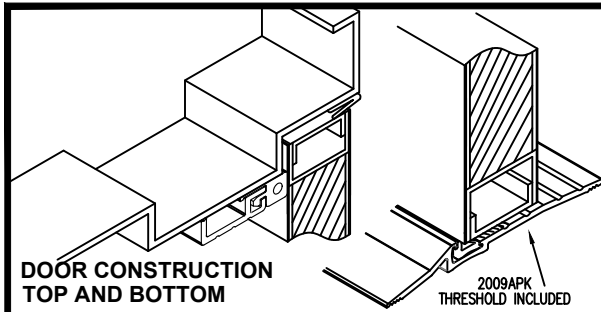
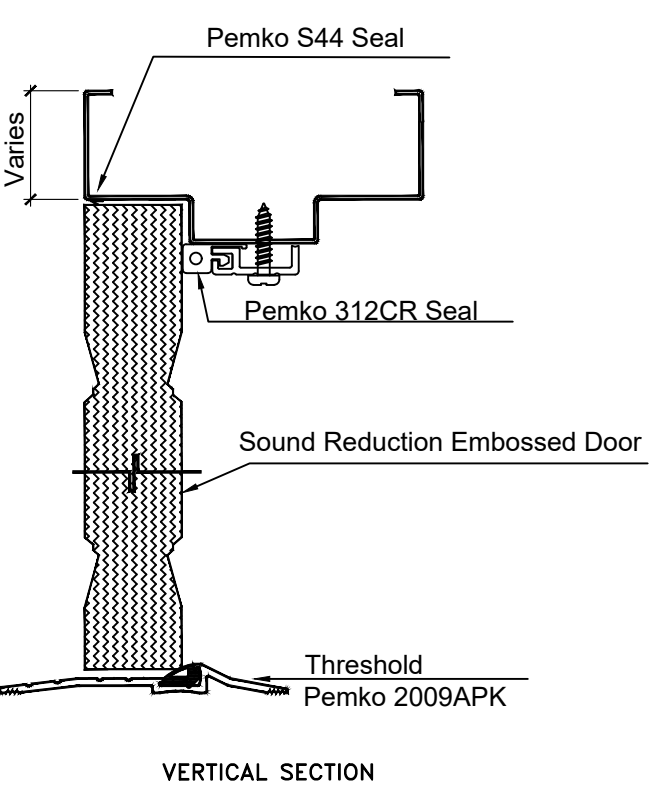

EMBOSSD DOOR DESIGNS

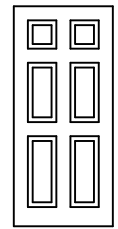

E601	
6 PANEL	
WIDTH	*28", 30"
HEIGHT	68", 70"
GAGE	18 STD., 16 OPT

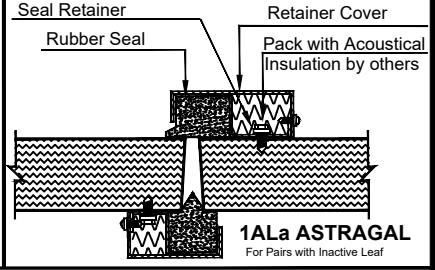
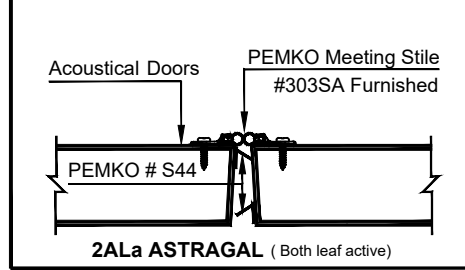
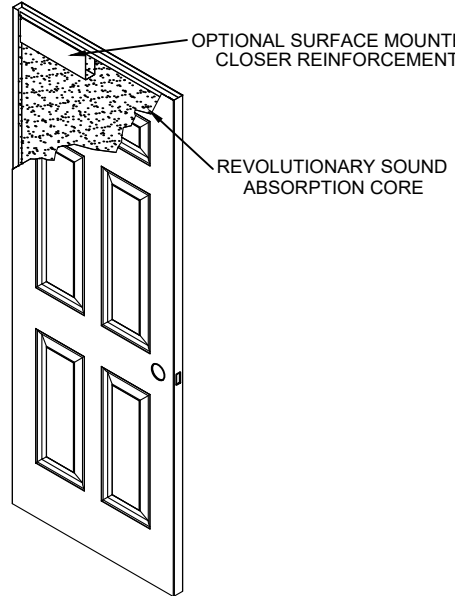

PRODUCT SPECIFICATIONS:

1-3/4" thick acoustical steel door system shall be as provided by Ceco Door Products, USA. Doors and frames shall conform to the Steel Door Institute guide specification, ANSI A250.8 as applicable.

The doors are commercial quality zinc coated A40 steel conforming to ASTM A653 & ASTM A924. Acoustic core and internal construction is manufacturer's proprietary standard as tested in accordance with ASTM E90, E413, E1332, & E2235 to furnish the STC rating specified. Door systems are in compliance with HMMMA 865 & SDI-128 specifications. A physical door label is applied to certify the product and identify the specific rating. The label will be applied to the door only and there will not be a label applied to the frames.

Frames are single or double rabbet profile of continuously welded construction and are available for any masonry and acoustic wall system applications. They are constructed of 16 gauge min. or 14 gauge max. to provide the STC performance specified. Frames are cold roll steel standard and galv. A60 is optional. Mutes are not allowed in these frames. Frames must also be grout filled to achieve the STC48 rating.

Hardware Provisions: Hinge preparations are handed. The square hinge edges are mortised for 4-1/2" or 5" high, standard or heavy weight hinges (specify which). Cam lift or offset pivots are not allowed. The door lock edge has a standard bevel and is prepared for ANSI A115.2 cylindrical lock only. Lock jamb preparation is for 4-7/8" high strike (ANSI A115.1 or 2).

Paint: Doors and frames shall be provided with one coat of oven-cured neutral color prime paint. Primer coat shall conform to ANSI A250.10. The primer coat is a preparatory base for necessary finish painting. "Colorstyle" finish coat is also available, for the door & 3 sided frame, from a selection of standard colors (optional). Colorstyle finish is electrostatically applied, oven-cured urethane enamel, and shall confirm to ANSI A250.3. For accurate color selectors ask for a Ceco Colorstyle chart.

Up to STC48 (6 panel Embossed Singles) □
1 3/4" Acoustical Door System
Tech. Data

FORM 1090-178R 06/21/16

FINISH:	STANDARD PRIMER PAINT; TESTED IN CONFORMANCE WITH ANSI A250.10
ACOUSTICAL PERFORMANCE	TESTED AND IN COMPLIANCE WITH ASTM E90, ASTM E413, ASTM E1332, & ASTM E2235. DOOR SYSTEMS ARE IN COMPLIANCE WITH HMMMA 865 & SDI-128 SPECIFICATIONS. COMPLETE WITH PERIMETER SOUND SEALS, BOTTOM SEALS AND THRESHOLD AS REQUIRED FOR RATING.

Experience a safer and more open world