

INSTALLATION INSTRUCTIONS:

DOOR SENSOR

Template(s): Use part as template
Use with: EMERGENCY DOOR ALARM
Tool(s) Required: Hex key (provided)
Hex nut driver
Phillips head screw drivers
Drill & Drill bits (1/8", .201" (#7),
1/2")
Pencil



NOTE: Parts received may be slightly different from parts shown in this document.

Please refer to packing list for details on parts received and fasteners received.

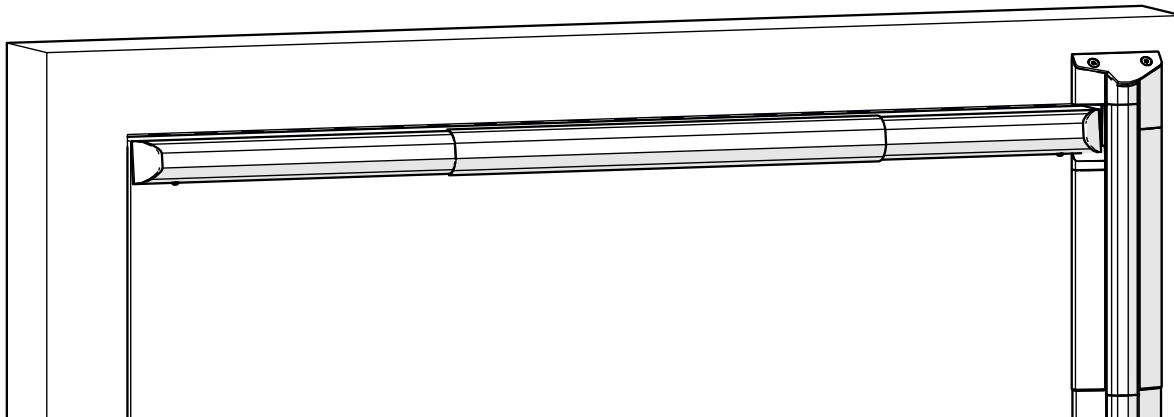

Questions? Please call Tech Support

800-622-5625



54-60 46th St., Maspeth, NY 11378

www.securitech.com

718-392-9000



Before you begin installation:

- Check that you received everything in the parts list.
- Read all of the installation instructions.
- Make sure that the surface of door where hinge will be installed is flush and without burrs.

DOOR SENSOR INSTALLATION

1 Hinge is installed before starting with sensor installation. 1/2" wiring holes are drilled already during hinge installation, refer to hinge instructions if wiring hole for sensor was not drilled.

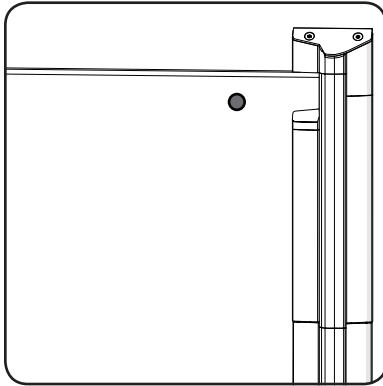

2 Mark a horizontal line 1" from the top of the door for models P1 and P2, or 3/4" for model P0, and extend to the lock side of the door.

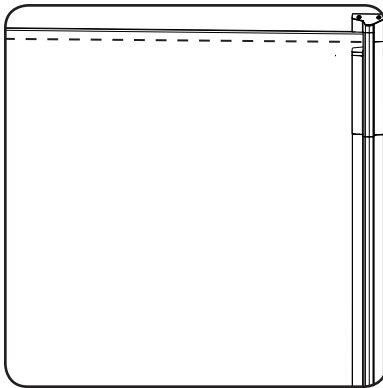

3 Mark a vertical line 1-1/8" from the notched edge of the hinge.

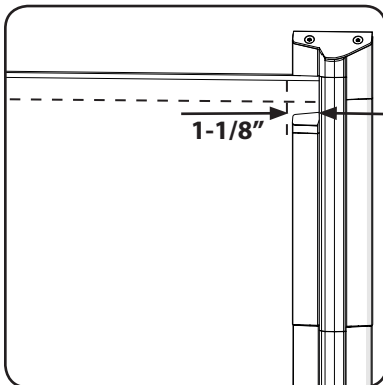

4 Mark centerpoint where horizontal and vertical lines intersect. Drill 1/8" pilot mounting hole.

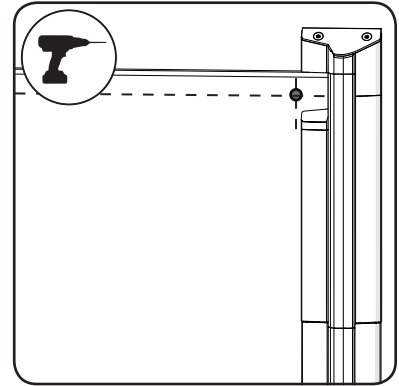

5 Loosen (2) cover screws enough to remove sensor cover from the sensor base using hex key provided. Do not remove the screws.

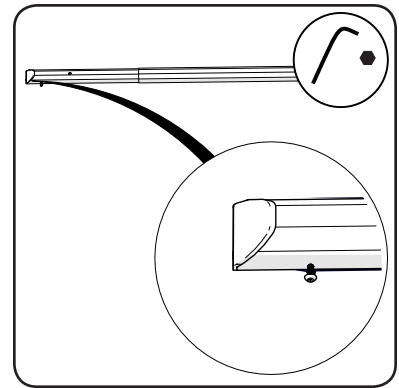

6 Place sensor base on the door. Pilot hole drilled in previous steps has to be aligned with the mounting hole. Pull out wire from wiring hole.

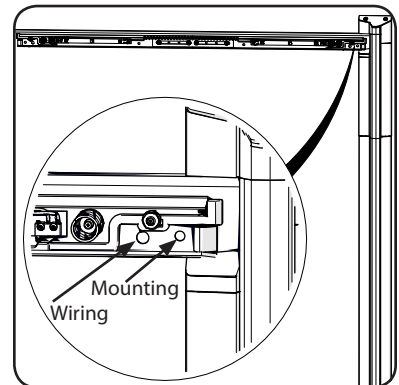

7 Temporarily secure the hinge side of sensor with (2) sheet metal/wood screws.

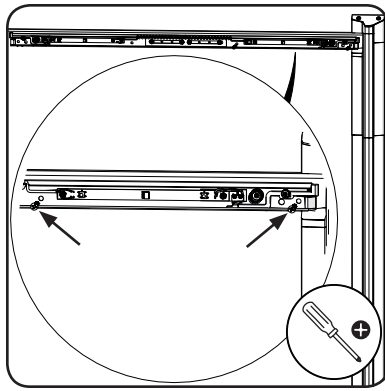

8 Loosen adjustment nuts on sensor plate and slide the sensor towards the lock side of the door. The gap between door edge and sensor plate is no more than 3/8" to 7/16".

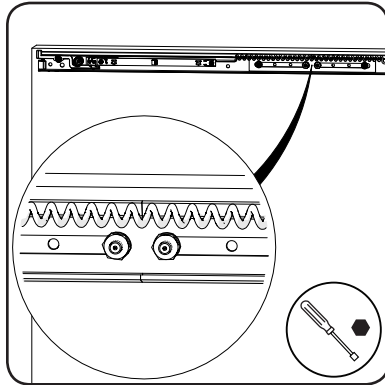

9 Adjust the length of cover as needed by loosening adjustment nuts. Tighten after cover is matching base.

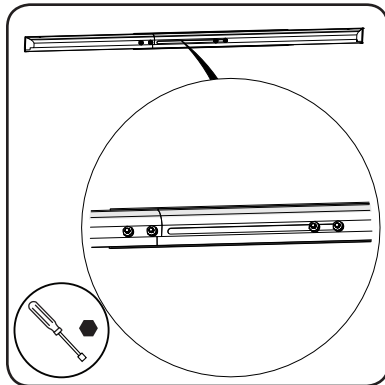

10 Align cover screws with slots on the sensor base. These must be matching on both ends of sensor. Repeat previous step if adjustment is needed.

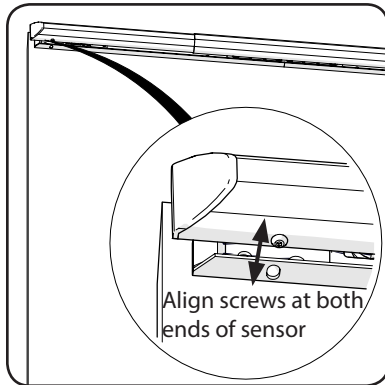

11 Attach cover to the sensor base and loosely tighten cover screws. Sensor cover must extend over the top of door, but make sure it does not extend more than 1/8". Test the operation.

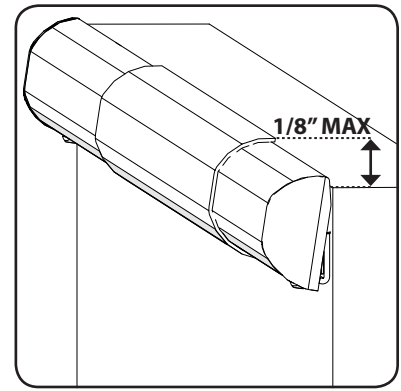

12 Remove the cover again. Mark the locations of lock side mounting holes. Remove the sensor base from the door. Prepare 4 mounting holes for thru-bolting. Drill \varnothing .201 (#7 drill bit) holes at 4 locations.

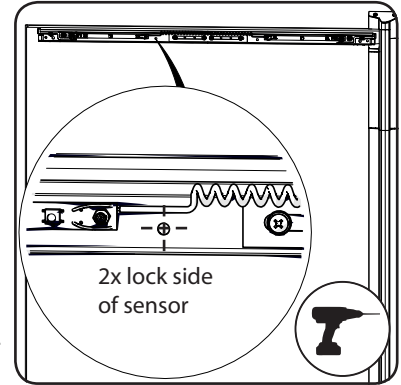

13 Install sensor base with (4) carriage bolts from the exterior, connected to flat washers, lock washers, and hex nuts on the interior. Adjust number of washers accordingly.

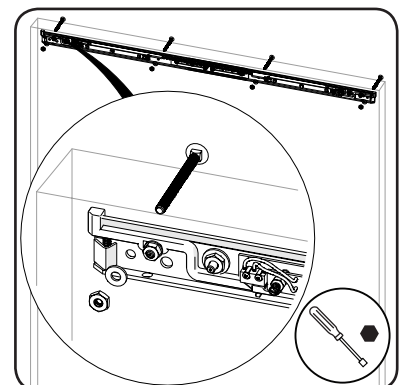

14 Optional: If needed cut the filler plate and fill the gap between lock side and hinge side of the base. Secure it through slot with (2) machine screws and flat washers.

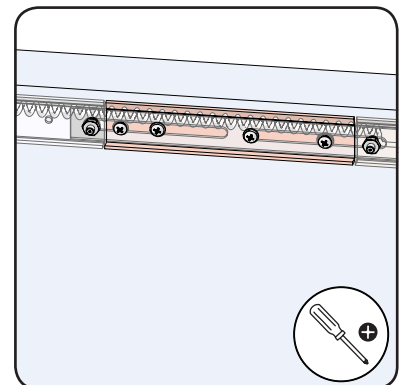

15 Tighten adjustment nuts on the sensor base.

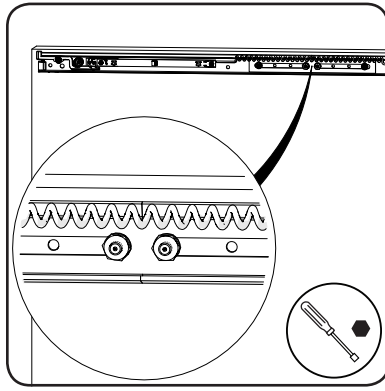

16 Snap the quick connector of wire to the plug on hinge side sensor board.

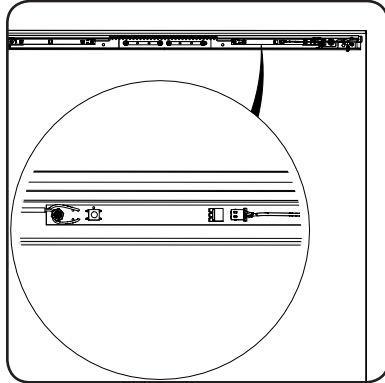

17 Secure sensor cover to the base with cover screws. Do not over-tighten screws. Test the operation. Press the sensor cover to check the sensitivity of the sensor.

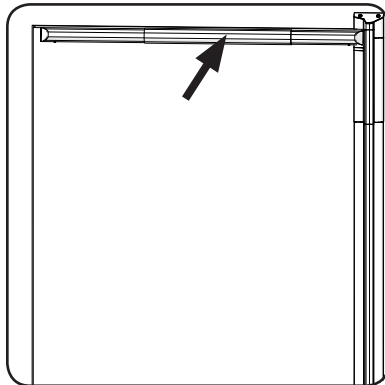

18 To change the sensitivity of sensor: detach the sensor cover. Tighten the hex nuts for less sensitivity and loosen the hex nuts for more sensitivity.

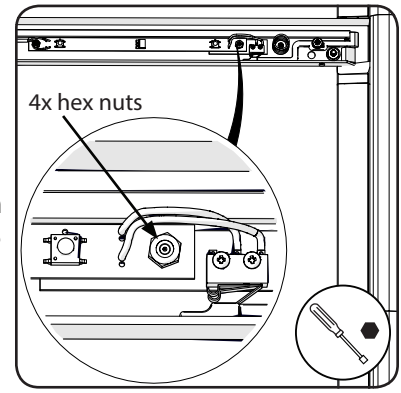

19 Connect sensor to the controller. Sensor switches are "NO", meaning the LED of console should stay green. If it turns red itself, adjust sensor for less sensitivity. Press the sensor down for 3 seconds and LED should turn red. If not, sensor should be adjusted for more sensitivity.

20 Repeat steps 17-19 until the sensor is at a desired sensitivity. When operating as desired, install sensor cover hand tight.

