



Safety glasses should be worn at all times while installing this product.

YEARS: 2015

MAKE: KIA

MODEL: SEDONA

STYLE: VAN

WARNING: NEVER EXCEED YOUR VEHICLE MANUFACTURER'S RECOMMENDED TOWING CAPACITY

WEIGHT CARRYING:
 TRAILER WEIGHT: 4,000 LBS.
 TONGUE WEIGHT: 400 LBS.

WEIGHT DISTRIBUTION:
 TRAILER WEIGHT: 4,000 LBS.
 TONGUE WEIGHT: 400 LBS.

PRO INSTALL TIME: 30 MIN.
NOVICE INSTALL TIME: 60 MIN.

IF YOU ARE HESITANT TO UNDERTAKE THIS TASK ON YOUR OWN, CONTACT AN AUTHORIZED CURT INSTALLER FOR ADDITIONAL ASSISTANCE.

INSTALLATION TIPS:

- BEFORE YOU BEGIN INSTALLATION, READ ALL INSTRUCTIONS THOROUGHLY.
- TO EASE INSTALLATION, 2 PEOPLE MAY BE REQUIRED.
- USING PROPER TOOLS WILL GREATLY IMPROVE THE QUALITY OF THE INSTALL AND REDUCE THE TIME REQUIRED.
- NEED HELP OR HAVE SOME QUESTIONS? CALL TECHNICAL SUPPORT AT 800.798.0813

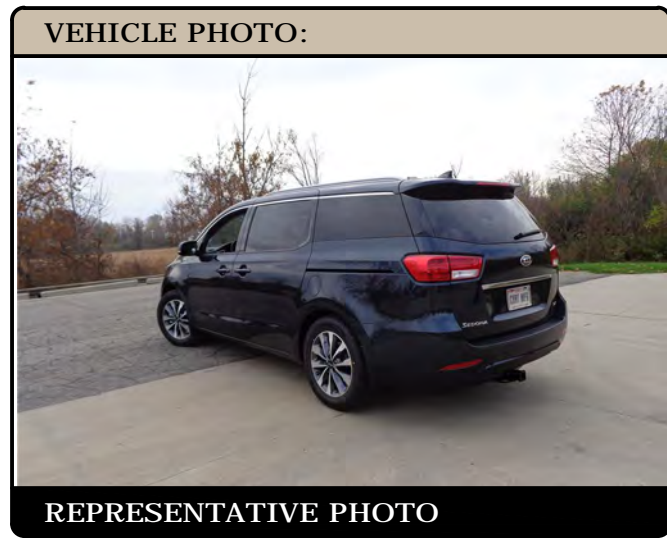

INSTALLATION REQUIRES:

SAFETY GLASSES	WIRE PIPE BRUSH	SPRAY LUBRICANT
SCREW DRIVER	RATCHET	12" SOCKET EXTENSION
19mm SOCKET	TORQUE WRENCH	

LEVEL OF DIFFICULTY: EASY

EASY	MODERATE	CHALLENGING
	LOWER EXHAUST	
	WELDNUT CLEANING	
	PART REMOVAL	
	NO DRILLING	

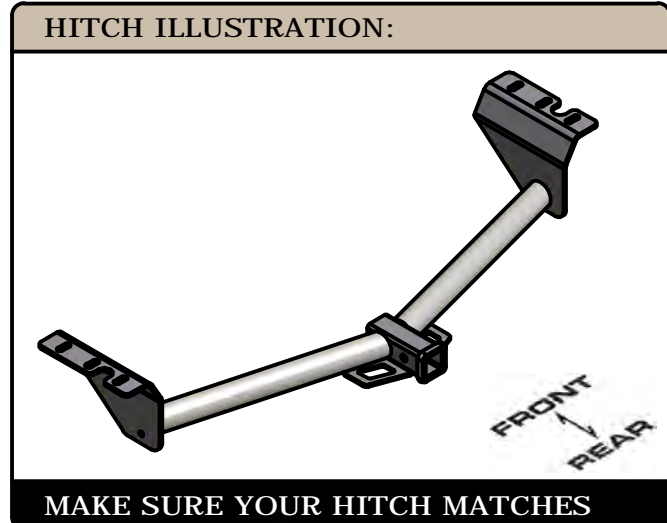

SCAN FOR MORE INFO

PERIODICALLY CHECK THIS RECEIVER HITCH TO ENSURE ALL FASTENERS ARE TIGHT AND ALL STRUCTURAL COMPONENTS ARE SOUND

CURT Manufacturing LLC. warrants this product to be free of defects in material and/or workmanship at the time of retail purchase by the original purchaser. If the product is found to be defective, CURT Manufacturing LLC. may repair or replace the product at their option, when the product is returned, prepaid, with proof of purchase. Alteration to, misuse of, or improper installation of this product voids the warranty. CURT Manufacturing LLC.'s liability is limited to repair or replacement of products found to be defective, and specifically excludes liability for incidental or consequential loss or damage. For more information log onto www.curtmfg.com, & for helpful towing tips log onto www.hitchinfo.com

INSTALLATION WALKTHROUGH:

Parts List			
ITEM	QTY	PART NUMBER	DESCRIPTION
1	6	M12-1.25 x 35mm	HEX BOLT
2	6	1/2"	CONICAL TOOTHED WASHER

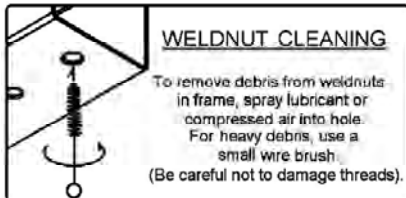
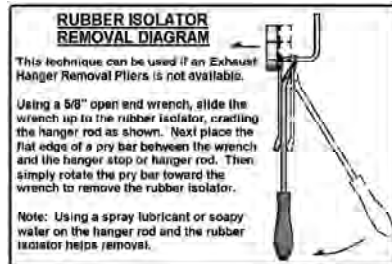
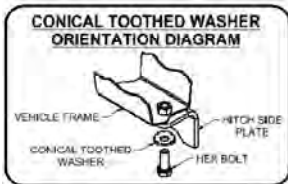
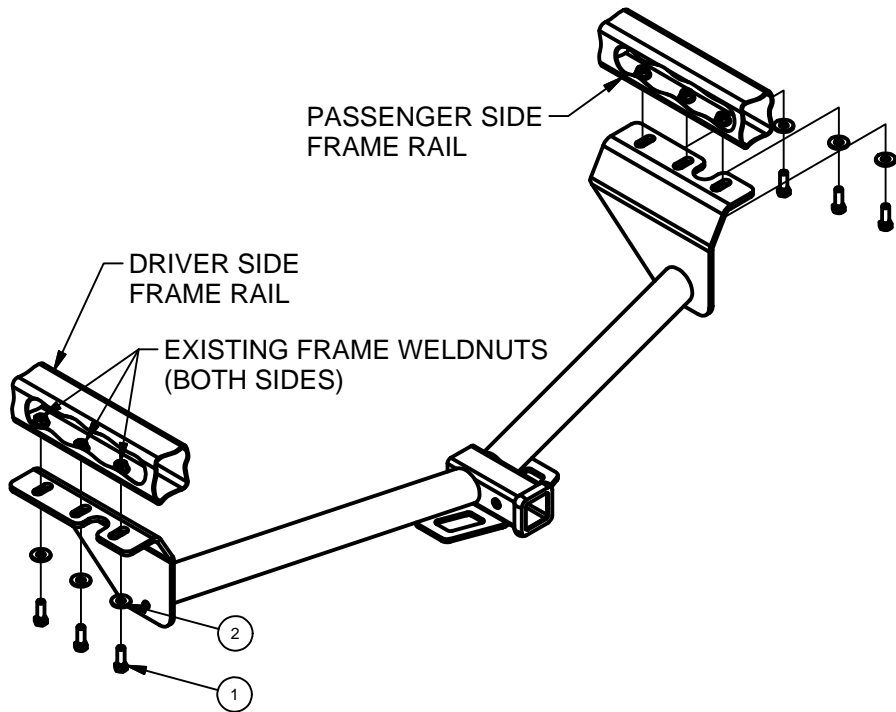

FRONT
↓
REAR

- 1.) Remove the driver side plastic panel, if equipped. Remove the plastic rivets and screws (6 places) securing the panel and return to owner.



- 2.) Lower the exhaust by removing the (4) rearmost rubber isolators from the muffler hangers. Support exhaust from underneath.



INSTALLATION WALKTHROUGH:

Note: Weldnut cleaning may be required prior to hitch installation. Use a wire brush and/or spray lubricant to clean the weldnut threads.

3.) Raise hitch into position and loosely secure by installing M12 bolts and washers with a 19mm socket as shown.



4.) Torque all M12 hardware to 86 ft-lb. Reattach all exhaust hangers.

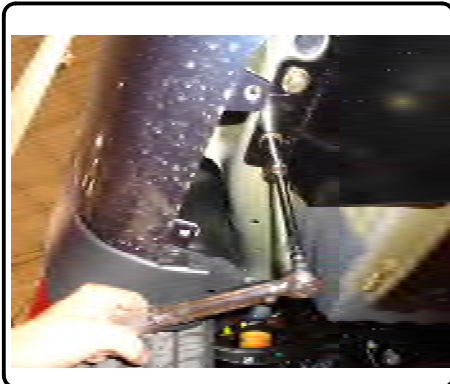

Installation complete



13115**KIA SEDONA****10/24/2014**

**GROSS LOAD CAPACITY WHEN USED AS A WEIGHT CARRYING HITCH: 4,000 LBS. TRAILER WEIGHT & 400 LBS. TONGUE WEIGHT.
GROSS LOAD CAPACITY WHEN USED AS A WEIGHT DISTRIBUTION HITCH: 4,000 LBS. TRAILER WEIGHT & 400 LBS. TONGUE WEIGHT**

*****DO NOT EXCEED VEHICLE MANUFACTURER'S RECOMMENDED TOWING CAPACITY.*****

HAVING INSTALLATION QUESTIONS? CALL TECHNICAL SUPPORT AT 1-800-798-0813

Parts List

ITEM	QTY	PART NUMBER	DESCRIPTION
1	6	M12-1.25 x 35mm	HEX BOLT
2	6	1/2"	CONICAL TOOTHED WASHER

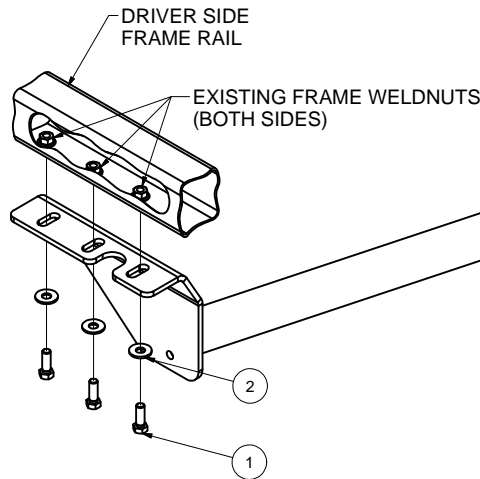
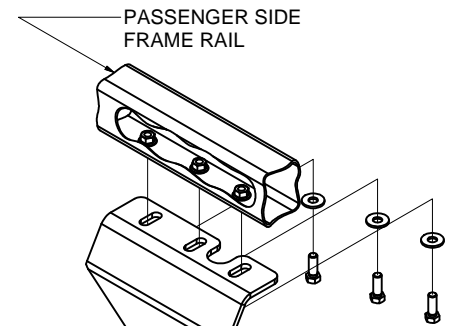
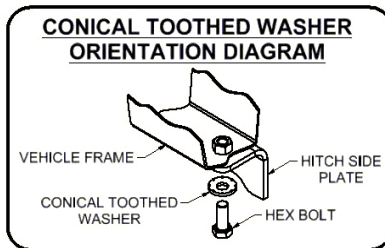
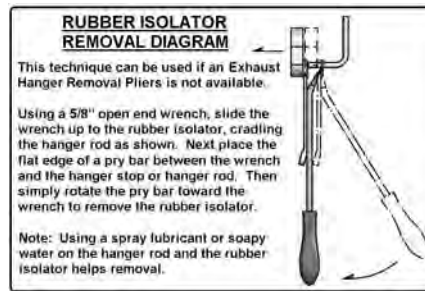
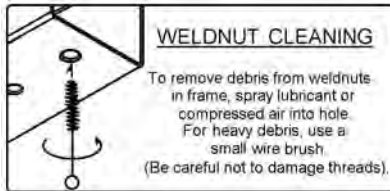

TOOLS REQUIRED
WIRE BRUSH
SCREWDRIVER
SPRAY LUBRICANT
19mm SOCKET
RATCHET
SOCKET EXTENSION
TORQUE WRENCH

HITCH WEIGHT: 43 LBS.

INSTALL TIME

PROFESSIONAL: 30 MINUTES

NOVICE (DIY): 60 MINUTES

INSTALL NOTES:

- WELDNUT CLEANING
- PART REMOVAL
- LOWER EXHAUST
- NO DRILLING

INSTALLATION STEPS

Note: Weldnut cleaning may be required prior to hitch installation. Use a wire brush and/or spray lubricant to clean the weldnut threads.

- 1.) Remove the driver side plastic panel, if equipped. Remove the plastic rivets and screws (6 places) securing the panel and return to owner.
- 2.) Lower the exhaust by removing the (4) rearmost rubber isolators from the muffler hangers. Support exhaust from underneath.
- 3.) Raise hitch into position and loosely secure by installing M12 bolts and washers with a 19mm socket as shown.
- 4.) Torque all M12 hardware to 86 ft-lb. Reattach all exhaust hangers.



Scan for more information

PERIODICALLY CHECK THIS RECEIVER HITCH TO ENSURE THAT ALL FASTENERS ARE TIGHT AND THAT ALL STRUCTURAL COMPONENTS ARE SOUND.

CURT Manufacturing LLC., warrants this product to be free of defects in material and/or workmanship at the time of retail purchase by the original purchaser. If the product is found to be defective, CURT Manufacturing LLC., may repair or replace the product, at their option, when the product is returned, prepaid, with proof of purchase. Alteration to, misuse of, or improper installation of this product voids the warranty. CURT Manufacturing LLC.'s liability is limited to repair or replacement of products found to be defective, and specifically excludes liability for incidental or consequential loss or damage.