



Pro-Matic 2 Pick-Up Truck Shifter

Fits most 2WD & 4WD Applications
With 3-Speed Automatic Transmissions

Chevrolet & GMC	All models using Turbo-Hydramatic 350 and 400
Ford	All models using C-4 and C-6
Mopar	All models using Torqueflite A-727 and A-904

Catalog #383 8510

Installation Instructions

Congratulations on your purchase of the Hurst...Pro-Matic 2, the finest ratchet action truck shifter available today. Show it off proudly...when properly installed, this shifter will assure you many years of high performance satisfaction by providing precise and positive gear change control for street or competition automatic transmissions. It is another high quality shifter built by Hurst Performance, "America's Number One Shifter".

FEATURES OF THE HURST PRO-MATIC 2 SHIFTER

- * Full ratchet action for quick, positive shifts.
- * Positive "Reverse Loc/Out".
- * Heavy-duty shifter cable, renowned for its superb quality and used by the most respected racers.
- * Engineered for years of precise, trouble-free shifting.
- * Easy to install and complete with all necessary mounting hardware.

Before you begin installation of the Pro-Matic 2 Shifter, please take a few minutes to read the installation instructions thoroughly.

IMPORTANT!

Read all of this information carefully.

1. All adjustments must be made with shifter and transmission in "Park", "Neutral", and "Low" gear positions.
2. Adjustments are critical and must be precise.
3. Do not mix components (all parts including shifter cable must be genuine Hurst components provided with kit).
4. If a shifter is removed and re-installed, adjustments must be checked and re-adjusted, if necessary.
5. When routing cable avoid sharp bends. Provide large full loops (if needed) for smooth shifting and long cable life. Avoid routing cable near exhaust pipes as heat from the exhaust system will melt cable casing. (Permanent damage of cable will result.)
6. Always check cable for freedom of movement before connecting to shifter and transmission control arm.

Failure to comply with any of the above may result in malfunction of shifter operation. Damage to cable due to sharp bending, kinking, or heat damage is not covered by warranty.

WORK SAFELY

Perform this installation on a good clean level surface for maximum safety and with the engine turned "Off".

Note: Installation of this shifter requires working underneath vehicle. Raise front of vehicle by lifting at points specified by the vehicle manufacturer. Place blocks or wedges in front of and behind both rear wheels to prevent movement in either direction. Support the vehicle with approved automotive support stands or wheel ramps. DO NOT USE A BUMPER JACK FOR SUPPORTING VEHICLE.

Caution: To avoid any possibility of bodily injury, do not get underneath vehicle until you are confident that it is safely supported and will not move or fall from its raised position.

For identification of shifter components, refer to the item number (circled in illustration) listed under IDENTIFICATION AND CONTENTS OF SHIFTER KIT.

TOOLS REQUIRED FOR INSTALLATION

2 or 4 Automotive Support Stands	Tape Rule
Car Ramps	Electrical Tape
1-1/2" Hole Saw	Pliers
9/32" Drill Bit	Flat Blade Screwdriver
Tin Snips	Phillips R Tip Screwdriver
Hacksaw (Ford only)	Ratchet-3/8" Drive
Hammer	10" Long Extension-3/8" Drive
File	7/16" Socket - 3/8" Drive
Center Punch	1/2" Socket - 3/8" Drive
Wire Strippers	9/16" Socket - 3/8" Drive
Wire Crimping Tool	3/8" Wrench-Open End
1/8" Drift Punch	7/16" Wrench-Open End
12-Volt Test Light or Voltmeter	11/16" Wrench-Open End
Electric Drill	Florescent Work Light

INSTALLATION OF PRO-MATIC 2 SHIFTER

1. Disconnect negative (-) battery cable.

Caution: When removing or connecting the battery cable terminal, use care to avoid intermittent contact (arcing or sparking) between battery post and terminal end. This generates voltage spikes that can damage sensitive ECM (Electronic Control Module) components or memory circuits.

2. Turn ignition key to "Unlock" position on steering column if equipped and place factory shifter in "Neutral" position.

Column shift lever: remove drive pin that fastens shifter lever to column, then remove lever from steering column. Disconnect and remove shift linkage rod from steering column inside engine compartment and linkage rod attached to transmission control arm.

3. Place Pro-Matic 2 Shifter stick in "Neutral" position and remove knob (Item #1). Lift console (Item #7) up and off. Remove one (1) #8 x 3/4" Phillips head screw (Item #2) that fastens chrome console cover (Item #5) to console and separate.
4. Position shifter in a desired location on floor allowing clearance for seat travel and shifter stick travel when shifting into "Park" position. Cut a small section of carpet or floor matting where shifter assembly will mount to floor (make sure there are no wires underneath carpet). Place shifter assembly (Item #8) in selected location, mark and center punch four (4) mounting holes. Drill through floor using a 9/32" drill bit. Deburr holes with a file and sand with emery cloth. (Refer to Figure 1).

5. If necessary, mark and cut a slit in the carpet to accommodate shifter cable. Using a hole saw or other suitable tool, make a 1-1/2" diameter hole in floor 3" in front of forward mounting hole and 1-3/4" to the left of forward mounting hole to accommodate shifter cable (Refer to Figure 1). For some vehicles the 3" dimension may be less. Deburr hole with a file and sand with emery cloth. Install rubber grommet (Item #13) into 1-1/2" diameter hole.
6. Attach shifter assembly to floor using four (4) 1/4"-20 x 1" hex head bolts (Item #9), 1/4" flatwashers (Item #20), and 1/4"-20 hex nuts (Item #15). Tighten securely. Install two (2) U-Type clip fasteners (Item #10) onto front and rear console mounting tabs of shifter frame. When installing these clips be sure extruded side is underneath mounting hole facing downward. (Refer to Identification and Contents of Shifter kit).

7. CABLE INSTALLATION

CAUTION: When installing shifter cable (Item #12), avoid sharp bends or kinks. Damage to cable due to sharp bending or kinking is not covered by warranty.

Remove 3/16" hex nut, two (2) rubber boots, two (2) 7/16" hex nuts, and two (2) internal tooth lockwashers from threaded end of shifter cable. Using tape, wrap the sections of cable that rubber boots were covering so dirt or grease will not get imbedded inside cable housing causing cable to scuff and bind. Insert cable from inside vehicle through rubber grommet in floor. Route cable so there are no sharp bends that would make the shifter hard to operate. Be sure cable clears all exhaust pipes by at least 1-1/2" (Refer to Figure 2).

Note: Use tie straps or clamps to secure shifter cable away from the exhaust pipes and engine.

Cable end with mounting tab attached (shifter assembly end) must slip into slotted opening on shifter frame. Position tab on the inside of shifter frame and fasten using 1/4"-20 x 3/4" hex bolt (Item #14) and 1/4" hex nut (Item #15). Slide cable end onto pin in shifter assembly and secure using 3/16" flatwasher (Item #16) and cotter pin (Item #17). (Refer to Identification and Contents of Shifter Kit).

Proceed to section that applies to the model and transmission of your vehicle.

GENERAL MOTORS

Turbo-Hydramatic 350 and 400

1. Remove backdrive linkage rod and stock transmission arm from gear selector shaft on transmission using a 9/16" socket and replace with Hurst transmission arm PT. 105 8561 (Item #25) re-using stock bolt or nut. Transmission arm must be installed with round hole down and bend in arm positioned away from transmission. (Refer to Figure 4).

IMPORTANT

VEHICLES EQUIPPED WITH STEERING COLUMN LOCK

In some applications the stock backdrive linkage system that locks the steering column and shifter in "Park" position may be retained depending on the stock transmission arm configuration.

One side of the stock transmission arm must have a flat unobstructed surface in order to be used and retain the factory backdrive linkage system. Carefully position Hurst transmission arm on top of or behind the stock transmission arm as illustrated. (Refer to Figure 3). The alignment of the mounting slots in both transmission arms is very important. With slots aligned, clamp arms together and weld along indicated lines. Allow transmission arm to cool, and replace onto transmission gear selector shaft using stock bolt or nut. Re-install backdrive linkage.

Note: If the backdrive linkage system is not going to be retained, the linkage rod lever (located inside engine compartment on steering column) must be secured in the upward position. This will allow ignition key to be turned to "Lock" position and withdraw freely out of lock.

2. Remove the two (2) center transmission oil pan bolts (using 1/2" socket) from left (driver) side of transmission as indicated. Attach Hurst cable bracket Pt. #117 4778Z (Item #24) to transmission oil pan re-using stock bolts. Do not overtighten. (Refer to Figure 4).

Note: Hurst shifter cable bracket features slotted mounting holes to allow for adjustment of cable forward or rearward.

3. Remove tape from cable and re-install rubber boots. Place shifter cable into mounting bracket on transmission oil pan and secure using two (2) internal tooth lockwashers and two (2) 7/16" hex nuts supplied with cable.
4. Be sure shifter stick is in "Neutral" position. Check and be sure transmission arm on gear selector shaft is also in "Neutral" position.

Thread cable pivot (Item #18) onto end of shifter cable. Adjust cable pivot until it slides freely into hole in transmission arm. When properly adjusted, lock cable pivot in place using 3/16" hex nut. Insert cable pivot end into transmission arm so pivot end is facing outward away from transmission. (Refer to Figure 4, & 7). Temporarily install cotter pin (Item #17).

MOPAR

Torqueflite A-727 & A-904

1. The stock backdrive linkage that locks shifter stick in "Park" position cannot be retained. Linkage rod lever (located inside engine compartment on steering column) must be secured in the upward position. This will allow ignition key to be turned to "Lock" position and withdraw freely out of lock.
2. Remove throttle lever located just above transmission arm by removing the bolt and nut, pry lever off the shaft using a flatblade screwdriver. Remove linkage and stock transmission arm. Install HURST transmission arm Pt. #105 8564 (Item #27) using the 1/4" x 1-1/2" hex bolt (Item #19), 1/4" split lockwasher (Item #23), and 1/4" hex nut (Item #15) supplied. Re-install throttle lever and linkage onto shaft. Check throttle lever to be sure it operates freely. (Refer to Figure 5).

3. Two (2) transmission oil pan bolts (driver side) directly below transmission arm must be removed. Install cable bracket Pt. #117 8563 (Item #26), two (2) spacers (Item #28), and two (2) 5/16"-18 x 3/4" hex head bolts (Item #21) supplied. If transmission has a cast aluminum oil pan, spacers may not be needed.
4. Remove tape from cable and re-install rubber boots. Place shifter cable into mounting bracket on transmission oil pan and secure using two (2) internal tooth lockwashers and two (2) 7/16" hex nuts supplied with cable. (Refer to Figures 2 and 5). It may be necessary to slightly bend the transmission cooling lines to attain clearance for cable.
5. Make sure shifter is in "Neutral" position. Check and be sure transmission arm on gear selector shaft is also in "Neutral" position.

Thread cable pivot (Item #18) onto end of shifter cable. Adjust cable pivot until it slides freely into hole in transmission arm. When properly adjusted, lock cable pivot in place using 3/16" hex nut. Insert cable pivot into transmission arm so pivot end is facing outward away from transmission. (Refer to Figure 5). Temporarily install cotter pin (Item #17).

FORD

C-4, & C-6

1. The stock backdrive linkage that locks shifter stick in "Park" position cannot be retained. Linkage rod lever (located inside engine compartment on steering column) must be secured in the upward position. This will allow ignition key to be turned to "Lock" position and withdraw freely out of lock.
2. Remove linkage and lever that is connected to the downshift lever shaft. Shift linkage rods should be disconnected and discarded. The original equipment neutral safety and back-up light switch that are found on some Ford transmissions should be disconnected and discarded. (Refer to Figure 6).
3. The stock transmission arm must be modified in order to install Hurst transmission arm Pt. 105 8559 (Item #31). Lower section of stock transmission arm must be removed (Refer to Figure 6A) to provide clearance for Hurst transmission arm.

Using a hacksaw, cut shaded section of transmission arm off so remaining arm is completely flat. Install Hurst transmission arm onto stock transmission arm pointing downward, with bend in arm away from transmission. Use 1/4" x 1-1/2" hex bolt (Item #19), 1/4" split lockwasher (Item #23), and 1/4" hex nut (Item #15) to secure Hurst transmission arm in place.

Re-install downshift lever, make sure o-ring is in position before installing lever onto shaft. Downshift lever must move freely.

4. C-4: Two (2) lower bolts (E) on the rear servo cover (F), must be removed. Install Hurst cable bracket Pt. #117 8558 (Item #29) on to servo cover, re-using factory bolts and tighten securely. (Refer to Figure 6B).

C-6: Two (2) transmission oil pan bolts at the left rear corner must be removed to install Hurst cable bracket Pt. #117 8557 (Item #30) and two (2) spacers (Item #28). Install cable bracket onto oil pan using the 5/16"-18 x 3/4" bolts (Item #21) supplied (Refer to Figure 6C). If transmission has a cast aluminum oil pan, spacers may not be necessary.

5. Remove tape from cable and re-install rubber boots. Place shifter cable into mounting bracket on transmission oil pan and secure using two (2) internal tooth lockwashers and two (2) 7/16" hex nuts supplied with cable.

6. Make sure shifter is in "Neutral" position. Check and be sure transmission control arm gear selector shaft is in "Neutral" position.

Thread cable pivot (Item #18) onto end of shifter cable. Adjust cable pivot until it slides freely into hole in transmission arm. When properly adjusted, lock cable pivot in place using 3/16" hex nut. Insert cable pivot end into transmission arm so pivot end is facing outward away from transmission. (Refer to Figure 6 & 7). Temporarily install cotter pin (Item #17).

NEUTRAL/PARK START SWITCH WIRING CONNECTION-EXCEPT MOPAR APPLICATIONS

Important: The Pro-Matic 2 shifter uses an electrical neutral/park start switch that replaces the original equipment neutral safety switch on most Chevy, GMC, Ford, Mopar applications. The original neutral safety switch is typically located at the lower end of steering column. For your particular application refer to the vehicle manufacturer's service manual for the correct location.

1. Pre-wire Hurst neutral/park start switch (front switch located on shifter assembly) using two (2) female crimp connectors (Item #22) and two (2) suitable lengths of 16 gauge insulated automotive grade wire (not supplied). Strip 1/4" of insulation off each end of wire and firmly crimp female connector onto one end of each wire. Push female connectors onto switch terminals. Route wiring away from shifter assembly so it will not interfere with internal moving parts. (Refer to Figure 8).
2. Locate wire connected to starter solenoid terminal marked "S" and trace to original equipment neutral start switch. Locate wire connected to "Solenoid" terminal of ignition switch and also trace to original equipment start switch. Disconnect both wires leading to original equipment switch and connect to Hurst neutral/park start switch wire leads. Use correct size insulated electrical butt connectors to properly connect the wires together. (Refer to Figure 8).

Note: If Pro-Matic 2 shifter is used in an application without an original equipment neutral/park start switch, locate wire connecting "S" terminal on starter solenoid to "Solenoid" terminal of ignition switch. Cut this wire and splice in the Hurst neutral park/start switch.

WARNING: Failure to wire and connect switch correctly can allow engine to start in "Drive" or "Reverse" causing unexpected vehicle motion and possible bodily injury or property damage.

BACK-UP LIGHT SWITCH WIRING CONNECTION-EXCEPT MOPAR 1969-LATER APPLICATIONS.

Note: For your particular application refer to the vehicle manufacturer's service manual for the correct location of original equipment back-up light switch.

1. Pre-wire Hurst back-up light switch (rear switch located on shifter assembly) using two (2) female crimp connectors (Item #22) and two (2) suitable lengths of 16 gauge insulated automotive grade wire (not supplied). Strip 1/4" of insulation off each end of wire and firmly crimp female connector onto one end of each wire. Push female connectors onto switch terminals. Route wiring away from shifter assembly so it will not interfere with internal moving parts (Refer to Figure 8).
2. Locate wire lead connected to back-up lights and trace to the original equipment back-up light switch. Disconnect both wires leading to the back-up light switch and connect to Hurst back-up light switch wire leads. Use correct size insulated electrical butt connectors to properly connect the wires together. Note: One wire lead from the Hurst back up light switch must have 12 volt power when the ignition key is in the "On" position. (Refer to Figure 8).

Mopar Applications
1969-Later

The original equipment factory back-up light switch is located on the transmission. No additional wiring is necessary.

SHIFT INDICATOR LAMP SOCKET WIRING CONNECTION

Use a suitable length of 22 gauge insulated automotive grade wire (not supplied). Strip 1/4" of insulation off each end of wire. Connect lead wire from light assembly (Item #11) to this wire using the correct size electrical butt connector. Connect other end of wire to electrical circuit of instrument panel lights.

Important: The shifter assembly must have a good chassis "ground" for indicator lamp to work properly.

SHIFTER OPERATION

Caution: Before testing shifter operation, it is recommended that vehicle be placed back on the ground, parking brake applied and wheels blocked. Vehicle should be parked in a safe location for testing. Be sure that no one is in front of or behind vehicle during testing.

Apply brake pedal pressure while testing. Familiarize yourself with the operation of this shifter by moving the shifter stick backward and forward through entire shift pattern (Refer to Figure 9). Move stick through each gear selection, counting positions as you feel them
P - R - N - D - 2 - 1.

Cable pivot attached to transmission control arm should be checked in "Park", "Neutral", and "Low" gear positions to be sure pivot slides freely "IN" and "OUT" of transmission arm. Move shifter stick into "Low" gear and check adjustment underneath vehicle by removing cotter pin and cable pivot from transmission arm. Check to be sure that transmission is FULLY ENGAGED in "Low" gear. When cable adjustment is correct, shifter will engage "Park" and "Low" gears completely. Once adjustment is made, secure cotter pins on either end of shifter cable and be sure all adjustment bolts and nuts are tightened securely.

WARNING: Correct cable adjustment is mandatory to insure that when shifter is in "Park" position, transmission is also fully into the "Park" detente. Failure to adjust cable correctly could result in unexpected vehicle motion when shifter is in "Park" or "Neutral" positions.

STARTER MOTOR AND BACK-UP LIGHT TEST OPERATION

We recommend disconnecting the "batt" wire from distributor so engine will crank but not start. Reconnect negative (-) battery cable. With the shifter in "Park" position and brake pedal pressure applied, test starter motor operation in every gear position of the shift pattern. The starter must operate in "Park" and "Neutral" gear positions ONLY. If starter operates in any other gear position, re-check wiring to be sure connections and adjustments of switches are correct. Test operation of back-up lights, they should operate in "Reverse" only. Turn "On" instrument panel and check illumination of gear indicator lamp.

Note: The Hurst neutral/park start switch and back-up light switch are pre-adjusted from the factory for your convenience. If adjustment is needed, loosen the screw located at the top of switch mounting bracket and pivot switch assembly inward until the required contact is made between switch and actuator plate. Shifter must be in the correct gear selection Park, Neutral, or Reverse when making this adjustment.

CONSOLE INSTALLATION

Note: In some applications shifter console must be trimmed to fit the contour of floor tunnel.

Place console (Item #7) over shifter assembly and hold it level with shifter. For proper installation, the inside of console top must rest on the two (2) mounting tabs of shifter frame.

Measure distance "A" from underside of console to the console mounting tabs on shifter assembly (Refer to Figure 10). Using a pair of dividers set to the dimension of distance "A", touch one end of dividers to console and other end to floor tunnel. Drag dividers along floor tunnel and against console scribing a line on the console to match the contour of floor tunnel by keeping dividers perpendicular to floor tunnel.

Using a utility knife, carefully score a firm cut over the line scribed into console. To prevent any unnecessary cracking, it is recommended that console be at room temperature before cutting or trimming. Remove any burrs or rough edges with a small file.

Insert indicator lens (Item #6) into chrome console cover (Item #5) and place onto console (Item #7), fasten using two (2) #8 x 3/4" phillips head screws (Item #2). (Refer to Identification and Contents of Shifter Kit for correct placement of indicator lens and screws).

Place console onto shifter assembly and fasten to mounting tabs on shifter frame using two (2) #8 x 1-3/4" phillips head screws (Item #3). Slide rubber boot (Item #4) over shifter stick and work it into the chrome console cover. Thread shifter knob onto stick, turn to desired position and tighten jam nut against knob.

GENERAL MOTORS VEHICLES EQUIPPED WITH STEERING COLUMN LOCK

Once all adjustments have been made and shifter functions properly, check operation of steering column lock. It must operate in "Park" position ONLY. It is very important that the column lock be adjusted correctly so that when shifter is placed into "Park" position, ignition key can be turned to "Lock" position. Steering wheel should lock and key should withdraw freely out of lock. The shifter then must not be able to be moved to any other gear position. If the shifter can be moved to other gear positions, column lock is not adjusted correctly and must be re-adjusted.

**SHIFTER OPERATION
GEAR SHIFT PATTERN CHANGES**

UPPER GATE MODE - GEAR SELECTION

The upper gear selection gate of the shifter operates "Park" and "Reverse". When in "Park" position, the shifter stick must be lifted to clear the safety stop between "Park" and "Reverse", then pulled straight back to engage "Reverse". Once in "Reverse" the handle will drop down slightly and shifter is ready to be pulled straight back to "Neutral". When "Neutral" is engaged the stick will drop again and enter the lower gate (ratchet mode) of shifter. (Refer to Figure 9).

LOWER GATE RATCHET MODE - GEAR SELECTION

The lower gear selection gate of the shifter operates "Neutral", "Drive 3", "Drive 2", and "Drive 1" (low gear). The shifter stick ratchets back and forth from "Neutral" to "Drive 1".

DOWN SHIFTING

- Park to Reverse - Lift stick, pull back to next detente for "Reverse".
Stick will drop down slightly.
- Reverse to Neutral - Pull back to next detente for "Neutral". Stick will drop down again.
- Neutral to Drive 3 - Push down then pull back to stop position and release for "Drive 3".
- Drive 3 to Drive 2 - Pull back again to stop position and release for "Drive 2".
- Drive 2 to Drive 1 - Pull back again to stop position and release for "Drive 1".

UP SHIFTING

- Drive 1 to Drive 2 - Push stick forward to stop position and release for "Drive 2".
- Drive 2 to Drive 3 - Push stick forward again to stop position and release for "Drive 3".
- Drive 3 to Neutral - Push stick forward to stop position and release for "Neutral".
- Neutral to Reverse - Lift stick upward, push forward to next detente for "Reverse"
- Reverse to Park - Lift stick upward, push forward to stop position for "Park".

Note: Retain this Instruction Sheet for Future Reference.

Page 10.

TECHNICAL SERVICE

A highly trained Technical Service Department is maintained by Hurst Performance to answer your questions, provide additional product information and offer various recommendations. See your local retailer of Hurst products for specific prices.

For best results, Technical Service calls, correspondence and warranty questions should be directed to the following address:

Hurst Performance
8700 Brookpark Road
Cleveland, Ohio 44129-6899

Phone: (216) 398-8300
8:30 A.M. - 5:00 P.M. EST
Monday - Friday

C 1992 Hurst Performance, 8700 Brookpark Road, Cleveland, Ohio 44129-6899
Made in U.S.A./Printed in U.S.A. PN 159 1043

FIG. 4

VIEW OF TH350 TRANSMISSION FROM UNDER VEHICLE

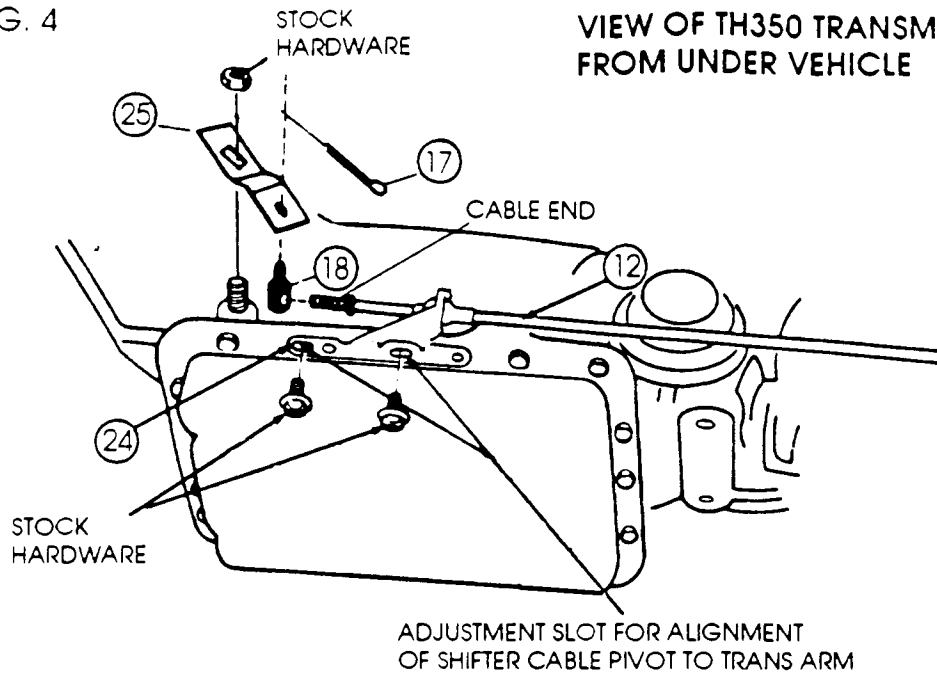

FIG. 5

MOPAR INSTALLATIONS A-727 AND A-904 TORQUEFLITE

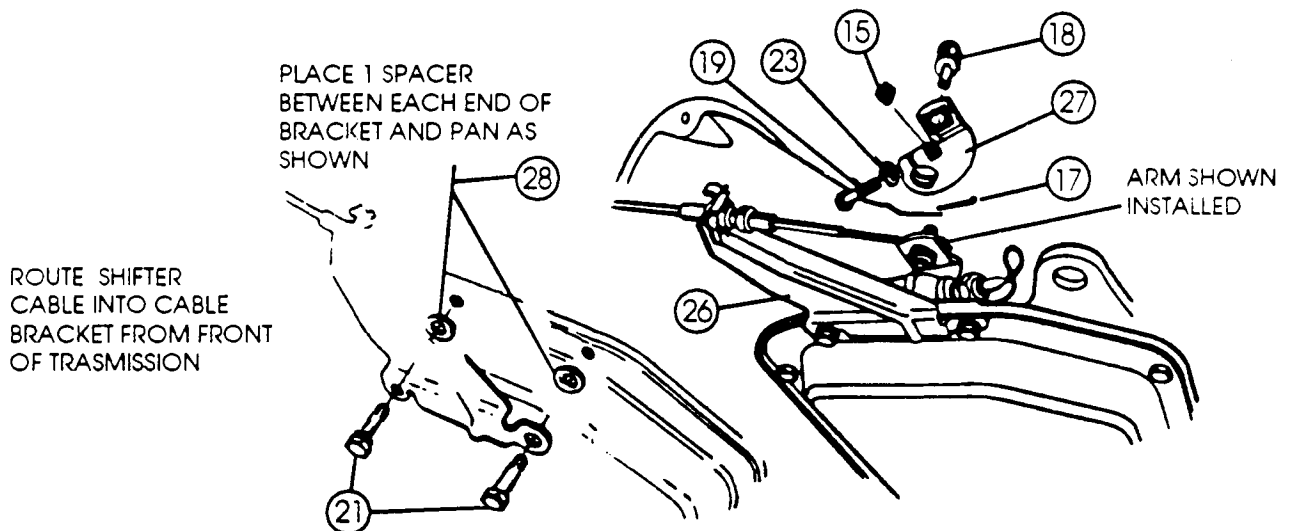

FIG. 6

FORD INSTALLATION C-4 AND C-6

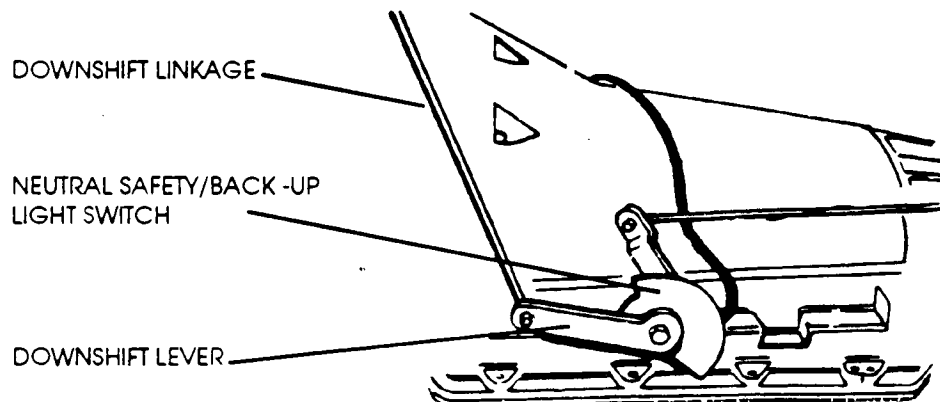

FIG. 6A

HURST TRANSMISSION ARM INSTALLATION

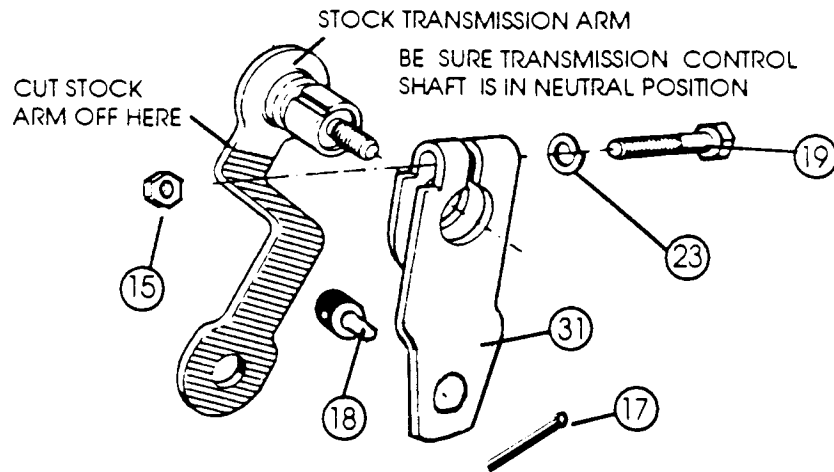

FIG. 6B

C-4 TRANSMISSION

TRANSMISSION ARM

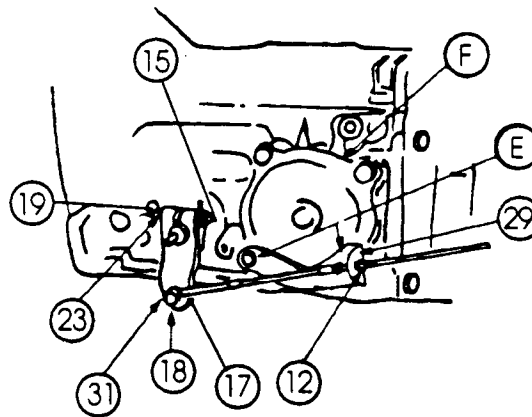
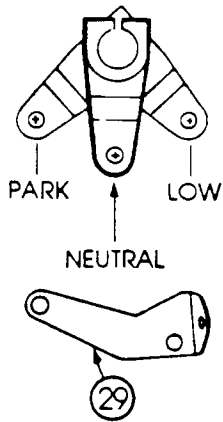

FIG. 6C

C-6 TRANSMISSION

TRANSMISSION ARM

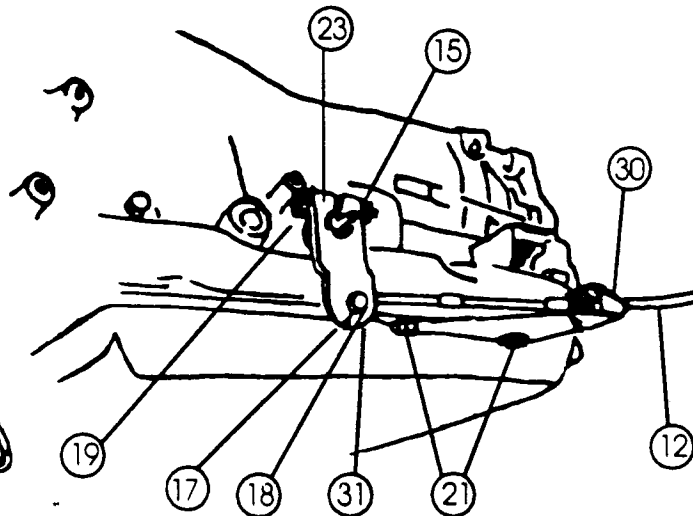
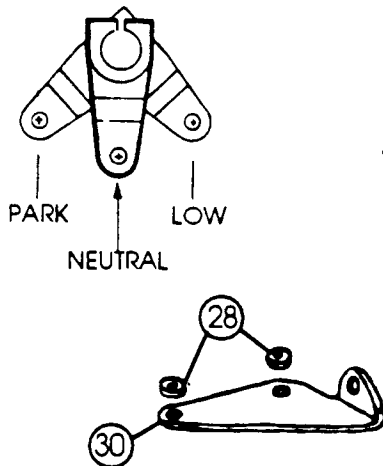

FIG. 7

ALIGNMENT PROCEDURE

1. PLACE SHIFTER STICK IN 'NEUTRAL' POSITION.
2. POSITION TRANSMISSION ARM AT 'NEUTRAL' POSITION.
3. INSERT CABLE PIVOT INTO TRANS. ARM, SECURE WITH COTTER PIN.

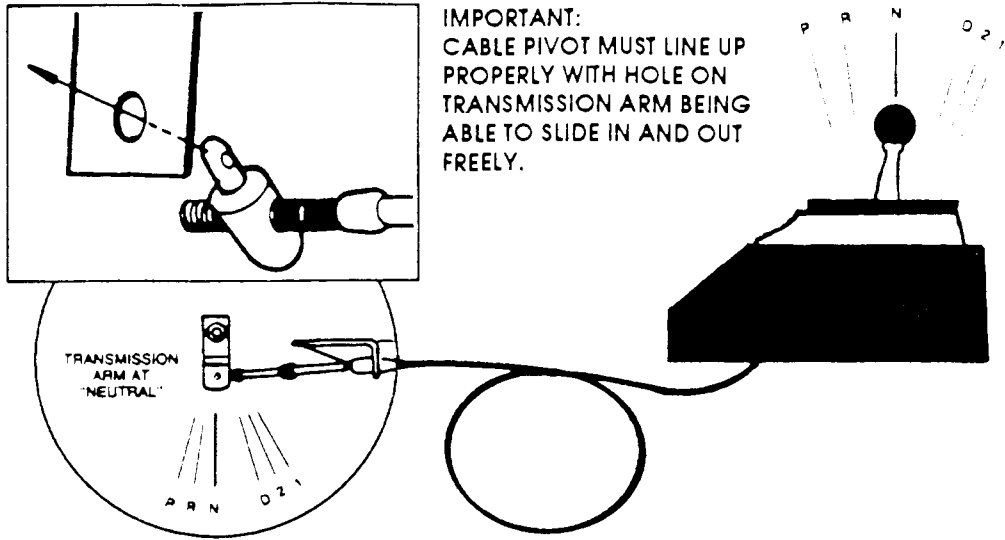

FIG. 8

PRO-MATIC 2 NEUTRAL/PARK START SAFETY SWITCH AND BACK-UP LIGHT SWITCH INSTALLATION

ORIGINAL NEUTRAL SAFETY SWITCH WIRING DIAGRAM SHOWN IS USED IN MOST VEHICLES. REFER TO THIS DIAGRAM WHEN WIRING AND CONNECTING HURST NEUTRAL/PARK STARTER SAFETY SWITCH AND BACK-UP SWITCH.

ORIGINAL NEUTRAL SAFETY SWITCH

(ONLY ONE OR THE OTHER IS USED ON ANY VEHICLE)

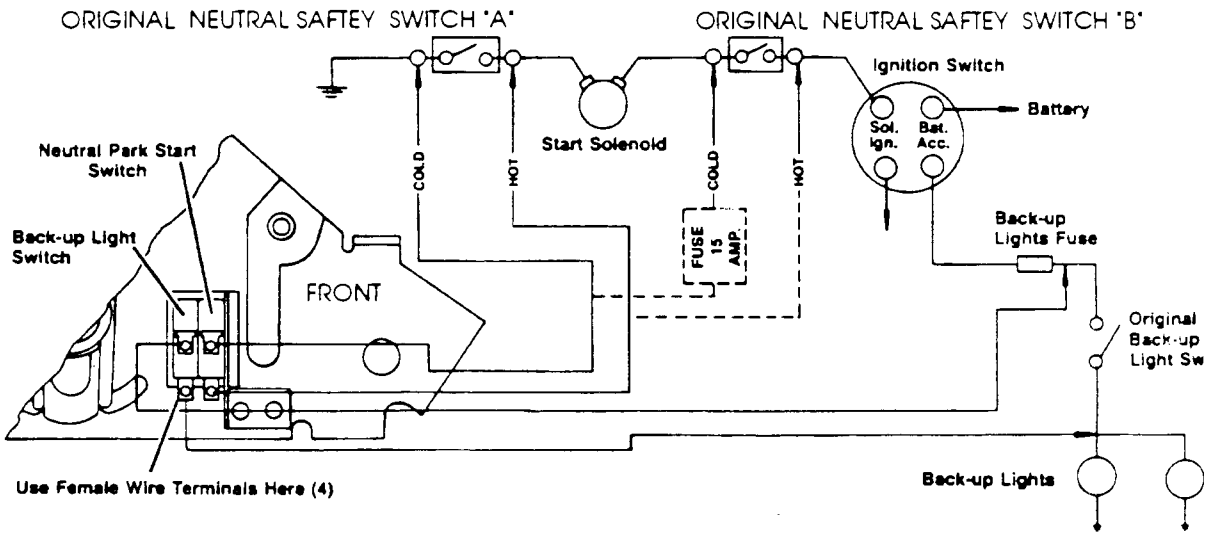

FIG. 9

SHIFTER OPERATION

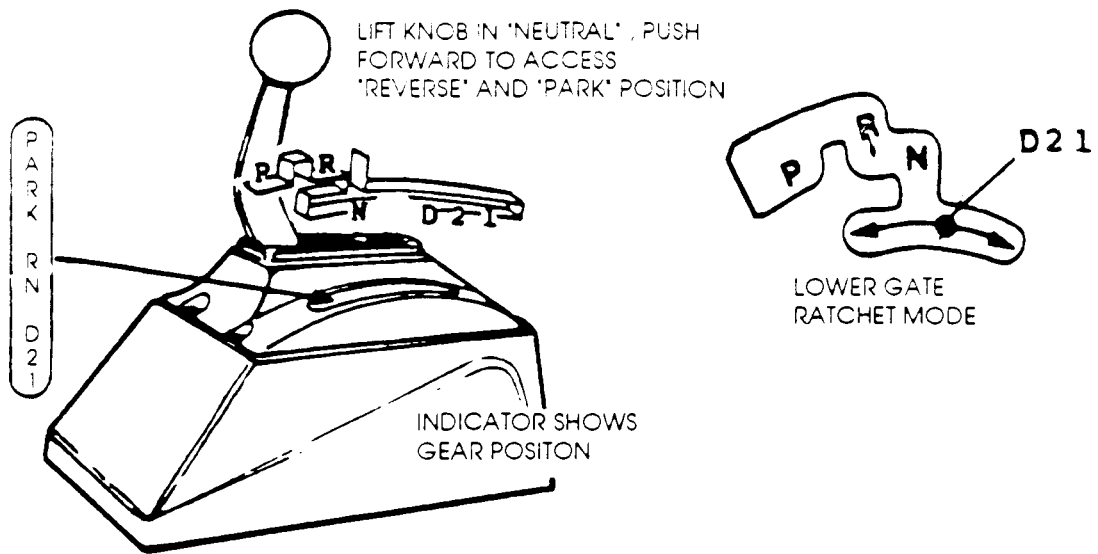
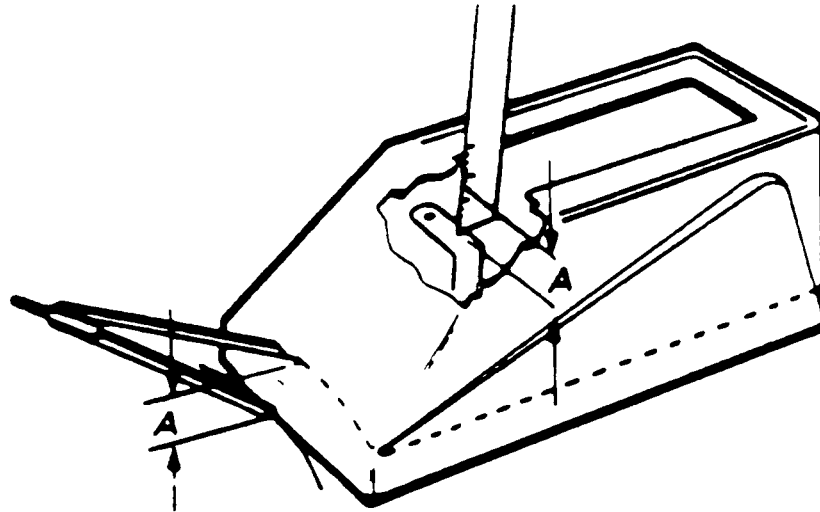

FIG. 10

CONSOLE INSTALLATION



1. Measure depth from top of shifter to below top of console.
2. Adjust points of divider to measure depth.
3. Scribe contours of floor along side of console as shown. Maintain divider in a perpendicular plane while scribing.
4. Trim portion below scribed line away. Fasten console to shifter with two #8x1-3/4" phillips head screws.

FIG. 1

TOP VIEW OF SHIFTER MOUNTING AND CABLE MOUNTING HOLE PATTERNS

FRONT OF SHIFTER

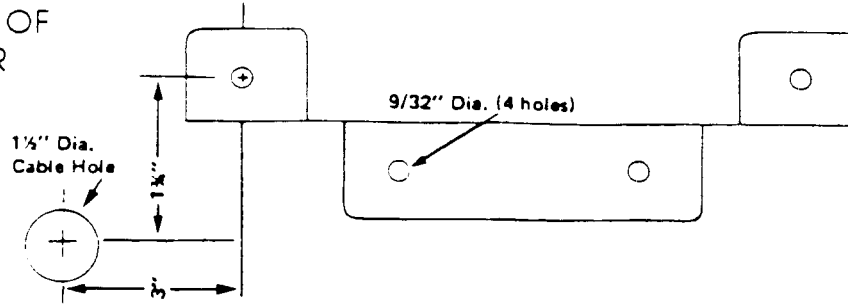

FIG. 2

SHIFTER CABLE ROUTING

MOPAR APPLICATION
ROUTE CABLE FROM FRONT OF TRANSMISSION

FORD AND GM
ROUTE CABLE BEHIND TAILSHAFT MOUNT

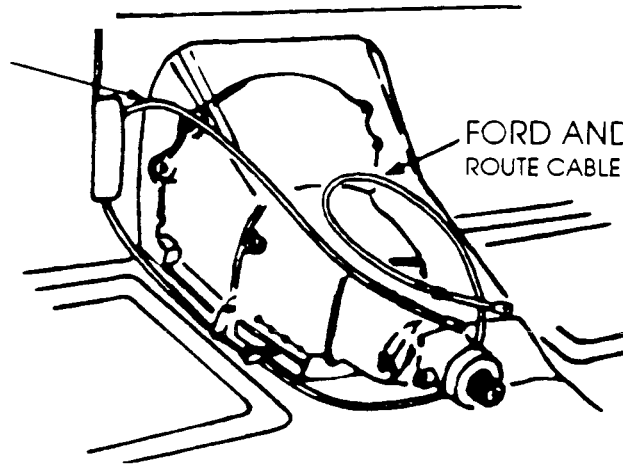
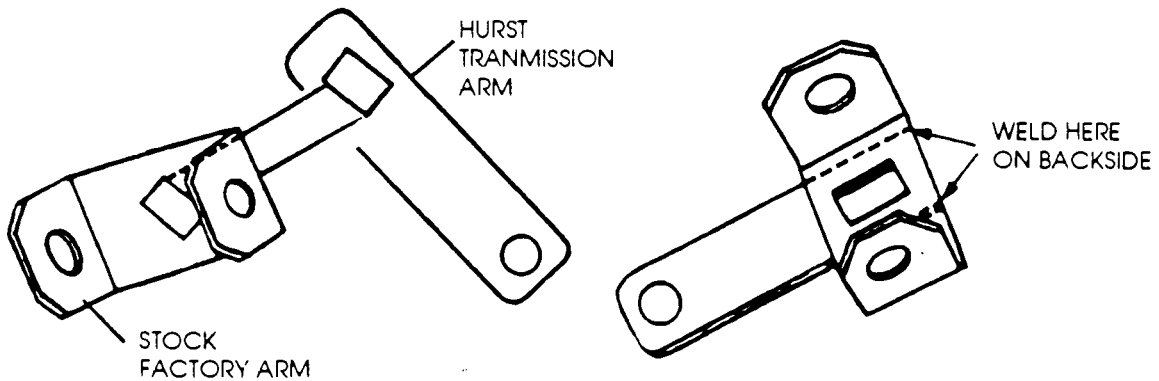
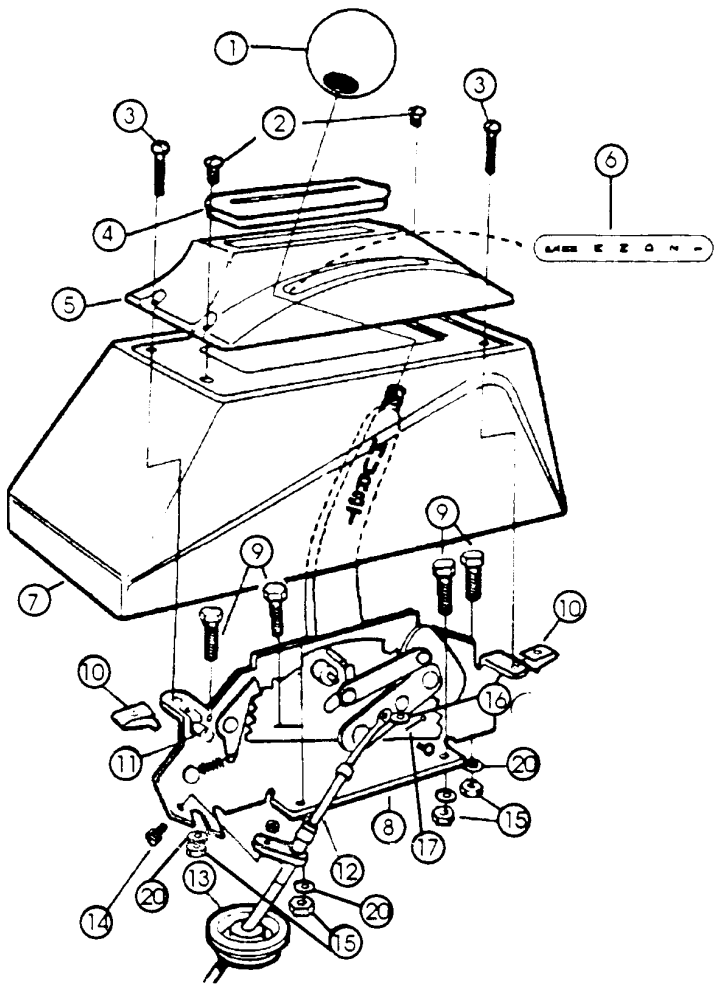

FIG. 3

GM TH350 AND 400 TRANSMISSION ARM MODIFICATION

POSITION OF FACTORY TRANS ARM ON TO HURST
TRANS ARM FOR WELDINGS OPERATION





IDENTIFICATION AND CONTENTS OF SHIFTER KIT

1. Shifter Knob	163 0064
2. Phillips Head Sheet Metal Screw #8 X 3/4"	97093105 (2)
3. Phillips Head Sheet Metal Screw #8 X 1-3/4"	97093106 (2)
4. Rubber Boot	114 8550
5. Console Cover	1958551
6. Indicator Lens	169 0005
7. Console	1298554
8. Shifter Assembly	383 0510
9. Hex Head Bolt 1/4" - 20 X 1"	97080969 (4)
10. U-Type Clip Fastener 1/4" - 20 X 3/4"	97093081 (2)
11. Indicator Light Assembly	166 0004
12. Shifter Cable	5008555
13. Rubber Grommet 1-1/2" Diameter	97093109
14. Hex Head Bolt 1/4" - 20 X 3/4"	97090029
15. Hex Nut 1/4" - 20	97000910 (6)
16. Flat Washer 3/16" I.D.	97000905
17. Cotter Pin 1/16"	97093086 (2)
18. Cable Pivot	97X93089
19. Hex Head Bolt 1/4" - 20 X 1-1/2"	97000913
20. Flat Washer 1/4" I.D.	97000818 (4)
21. Hex Head Bolt 5/16" - 18 X 3/4"	97000416 (2)
22. Female Wire Connector	252 7600 (4)
23. Split Lockwasher 1/4" I.D.	97090082

GENERAL MOTORS

3-SPEED TURBO-HYDRAMATIC 350 & 400

24. Bracket-Shifter Cable TH 350 & 400	117 4778Z
25. Transmission Arm TH 350 & 400	105 8561

MOPAR

3-SPEED TORQUEFLITE A-727 & A-904

26. Bracket-Shifter Cable A-727 & A-904	117 8563
27. Transmission Arm A-727 & A-904	105 8564
28. Spacers-Cable Bracket	97093092

FORD

3-SPEED TORQUEFLITE A-727 & A-904

29. Bracket-Shifter Cable C-4	117 8558
30. Bracket-Shifter Cable C-6	117 8557
31. Transmission Arm C-4 & C-6	105 8559