

Installation Instructions

19K Sidewinder™

Part Numbers:

SW19K, ST100-SW19K, ST200-SW19K, ST300-SW19K, ST400-SW19K, ST500-SW19K, ST100-SW19KPOE*, ST200-SW19KPOE*, ST400-SW19KPOE*

* = Pre-Assembled

DEALER/INSTALLER:

(1) Provide this Manual to end user

END USER:

(1) Read and follow this Manual every time you use Sidewinder.

(2) Save this Manual for Future Reference.

(3) Pass on copies of Manual to any other users or owner.

Do Not Exceed Lower of Towing Vehicle Manufacturer's Rating, Trailer Manufacturer's Rating or

Max Gross Trailer WT (LB)	Max Pin WT (LB)
19,000 LB	3,800 LB

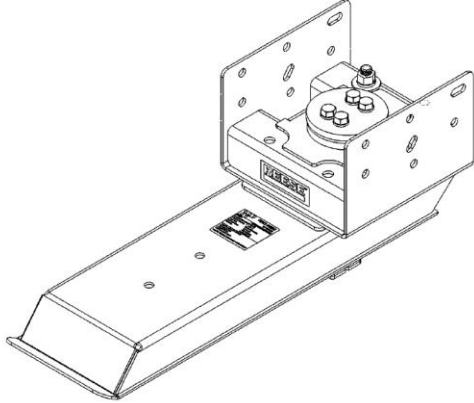

PIN BOX SHOWN ASSEMBLED

Equipment Required:

Fastener Kit: ST100F

Wrenches: 15/16", 1 1/8"

Drill Bits: Not Required

White Lithium Grease, Torque Wrench

①	Qty. (1)	Turret (ST100, ST200, ST300, ST400, or ST500)
②	Qty. (1)	Wear Plate
③	Qty. (1)	19K Sidewinder™
④	Qty. (1)	Universal Wedge*
⑤	Qty. (6)	5/8" Lock Washer
⑥	Qty. (2)	Wedge Bolt, 5/8"-11 X 1 3/4" Grade 5 Hex Bolt
⑦	Qty. (4)	Cap Bolt, 5/8" - 11 X 2" Grade 8 Hex Bolt
⑧	Qty. (2)	3/4" - 10 Hex Nut**
⑨	Qty. (2)	3/4" Lock Washer**
⑩	Qty. (4)	3/4" Flat Washer**
⑪	Qty. (1)	Outer Cap
⑫	Qty. (1)	Upper Wear Disc
⑬	Qty. (1)	Pivot Bushing
⑭	Qty. (2)	Convertible Bolts, 3/4" - 10 X 9" **

*Custom Wedges are available for most fifth wheel hitch applications, to order a custom wedge kit, see your RV Dealer or contact CPP Technical Service: 1-888-521-0510.

**Included on OEM installed units only.

INDEX

1. GUIDELINES FOR MATCHING TOW VEHICLE AND TRAILER	P. 2-3
2. ASSEMBLY INSTRUCTIONS	P. 4-6
3. OPERATION INSTRUCTIONS	P. 6-10
4. WEDGE ADJUSTMENT/SELECTION	P. 7-8
5. HITCHING PROCEDURE, PULL TEST, UNHITCHING PROCEDURE	P. 9-11
6. BEFORE EACH TRIP	P. 11
7. MAINTENANCE	P. 11
7. NOTES	P. 12
8. LIMITED LIFETIME WARRANTY	P. 12

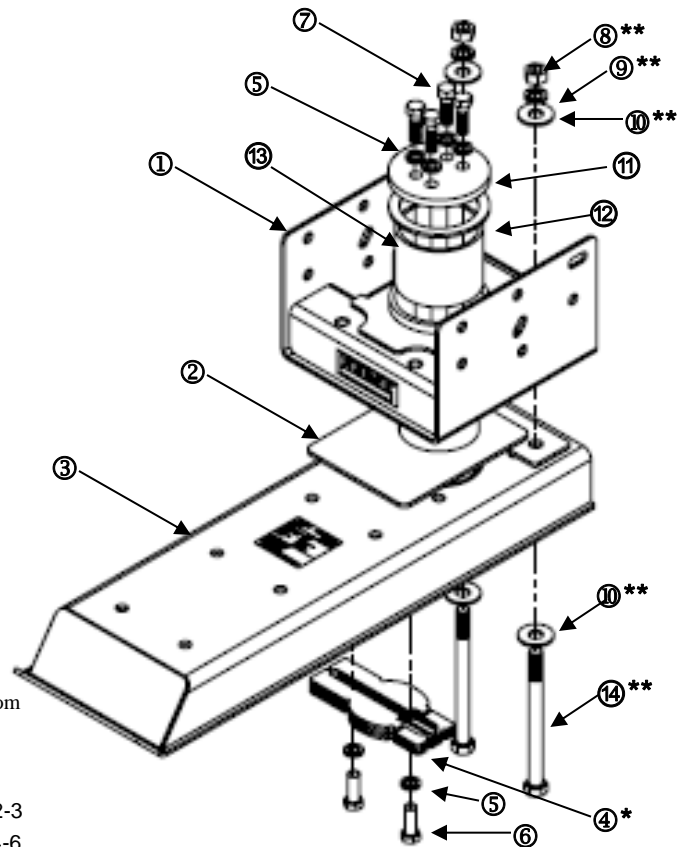

Figure 1

⚠ WARNING:

Failure to follow all of these instructions may result in death or serious injury!

Installation Instructions

19K Sidewinder™

GUIDELINES FOR MATCHING TOW VEHICLE AND TRAILER

⚠ WARNING:

Failure to check and follow tow ratings could result in tow vehicle damage or truck and trailer separation while towing.

- Trailer and its contents together must not exceed truck, hitch and/or trailer tow ratings.
- Towing vehicle must have a manufacturer's rated towing capacity equal to or greater than the gross trailer weight (dry weight of the trailer plus payload of the trailer). (See Fig. 2)
- Gross weight of trailer must not exceed 19,000 pounds for this product.
- King pin weight must not exceed 3,800 pounds (See Fig. 3). If in doubt have king pin weight measured by qualified facility.

1. Check Tow Ratings:

Vehicle Tow Rating: _____.

19K Sidewinder Pin Box Rating: **19,000 lbs.**

Gross Trailer Weight (Figure 2): _____.

***Trailer weight should be the lowest of these recorded ratings for safe towing conditions.**

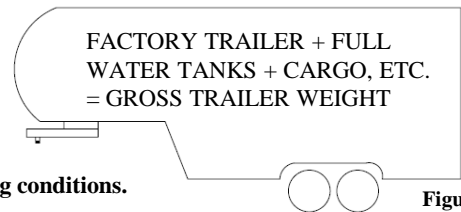

Figure 2

2. The Sidewinder™ pin box is designed for a maximum of 20% Gross Trailer Weight on the pin (Pin Weight). See Fig. 3

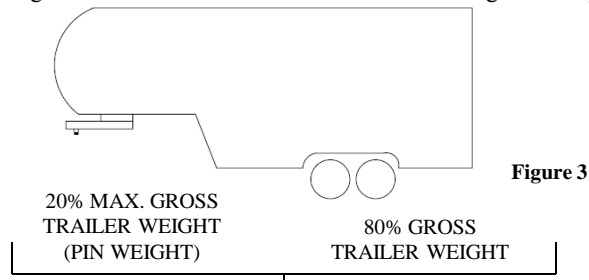

Figure 3

3. Trucks & RV Trailers come in many different configurations; Installations of 5th Wheel Hitches often vary by installer, it is necessary to check the clearances in figures 4 & 5 before hook up and towing with Sidewinder™.

Pre Hook-up Clearance Check

I. Cab Clearance

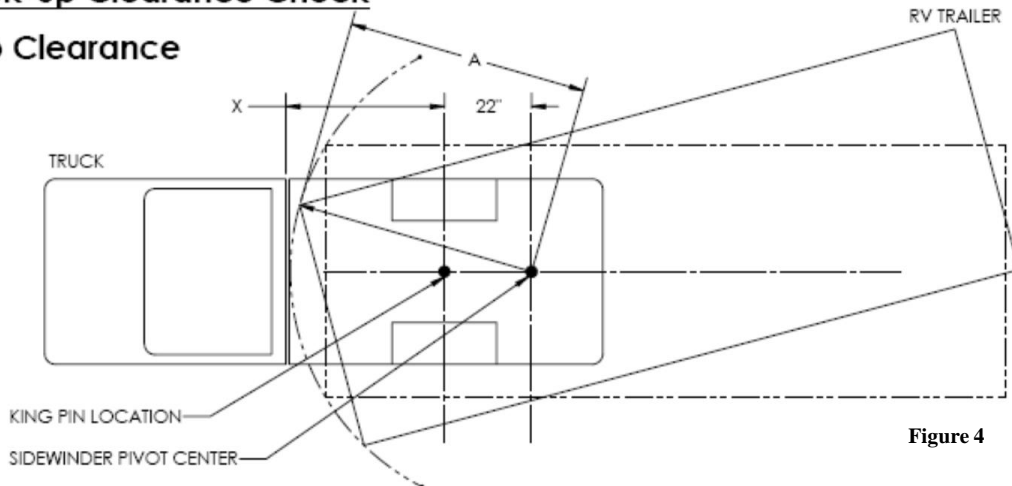

Figure 4

Measure Distance "A": From Center of Sidewinder™ pivot to farthest point on coach front cap.

Measure Distance "X": From King Pin to the rear of the truck cab.

If Distance "X" + 24" is Greater Than Distance "A" Towing up to 90° or More is possible.

Installation Instructions

19K Sidewinder™

GUIDELINES FOR MATCHING TOW VEHICLE AND TRAILER – CON'T

II. Bumper Clearance

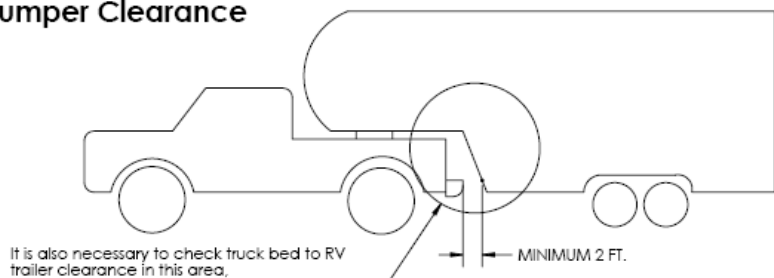

Figure 5

CAUTION: A minimum clearance between the bumper and trailer (Measured at the same height) of 2 ft. is recommended. Due to Vehicle and RV Trailer variations; it is necessary to check this clearance. If the clearance is less than the minimum, this can be done after installation by making a slow turn, in a controlled driving environment (i.e. closed parking lot, grass field, etc.) with the aid of an observer to watch for interference.

4. The Height of the hitch and pin box should be adjusted so the trailer is approximately level as it is towed. Allow approximately 6 in. clearance between the top of the bed and the underside of the front of the trailer for pitch and yaw of the trailer (See Figure 6). For off-road use allow more clearance between pickup walls and trailer.

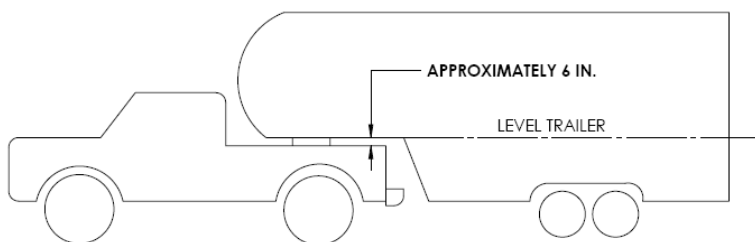

Figure 6

CAUTION:

The Measurements in figures 4, 5 & 6 are guidelines, If your measurements are close to these numbers, re-check clearances. If vehicle and/or trailer has any added bed vanity accessories (i.e. fairings, air dams, ground effects, bed rails, etc.) additional dimensioning and clearance checks have to be made. CPP is not responsible for damage incurred due to disregarding these clearance checks.

WARNING:

•Cequent Performance Products does not recommend the use of a Sidewinder™, 5th Airborne Sidewinder™, or Revolution™ with the following:

- Curt Q5 Fifth Wheel Hitch,
 - PullRite Super Glide
 - Reese Trail Boss 5th Wheel Head.
 - B&W 5th Wheel Hitches
 - Colibert 208BW
 - Hi-Rise (Draw-Tite #9480 Bulldog #9481)
 - Any other 5th wheel adaptor that connects to a goose ball
- Do not use a lube plate with Sidewinder™ & 5th Airborne Sidewinder™

WARNING:

Avoid putting any part of your body under the trailer or between the truck and trailer. Unexpected or accidental movement of the truck or the trailer can cause serious injury or death

•If you must place any part of your body under the trailer or between the truck and trailer you **MUST** perform **ALL** of the following steps:

- Check that the truck transmission is in park
- Check that the emergency brake is set
- Block in front of and behind all trailer tires
- Check that the trailer landing gear are resting on firm ground

Installation Instructions

19K Sidewinder™

ASSEMBLY INSTRUCTIONS – For Pre-Assembled OEM Models use this section as a point of reference.

1. Before removing the original pin box, take note of the number of bolts used attaching the existing pin box to the mounting wing set. Cequent Performance Products recommends using at least the same number of bolts upon installation as removed from the original pin box. (Figure 7)

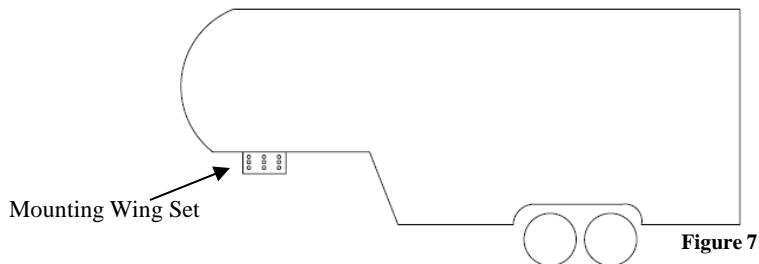

Figure 7

2. Check all boxes for all components listed in figure 1.
3. Remove the existing pin box, taking care to remove any necessary wiring and/or break away switch if attached to the pin box. (If removed, the break away switch must be reinstated after installation is complete)
4. Install the turret inside the mounting wings (Figure 8). Cequent Performance Products recommends replacing the mounting bolts, nuts, and lock washers with the same size & grade as the bolts removed from the original pin box. Torque all bolts to the proper value listed in table 1.

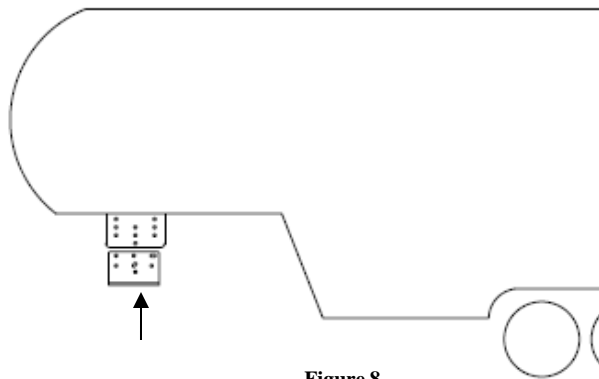

Figure 8

Bolt Diameter	Torque
1/2" Bolts GR5	90 ft-lbs
5/8" Bolts GR5	150 ft-lbs
3/4" Bolts GR5	275 ft-lbs

Table 1

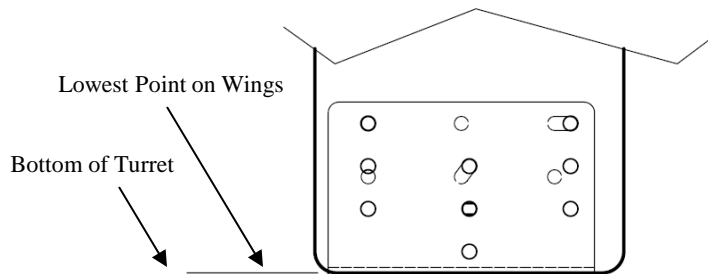

Figure 9

Note: Installing the front bolts first may ease alignment.

CAUTION: The bottom of the turret must extend below the lowest point on the wings to allow the arm to clear during pivot. (Figure 9)

4. Install pivot bushing into the turret as shown in figure 10. Applying white lithium grease to the inner tube of the turret may ease assembly. Install wear plate onto sidewinder arm (Figure 11), be sure to place the chamfer facing down (Figure 12). Apply white lithium grease to the surfaces shown in figure 13, be sure to coat the entire surface.

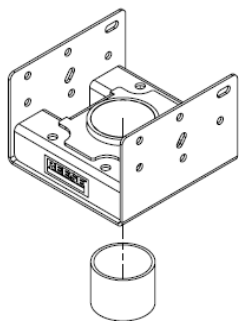

Figure 10

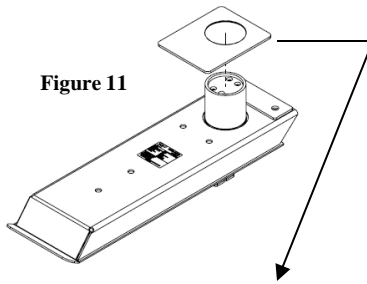

Figure 11



Figure 12

The chamfer on the wear plate Must face down as shown

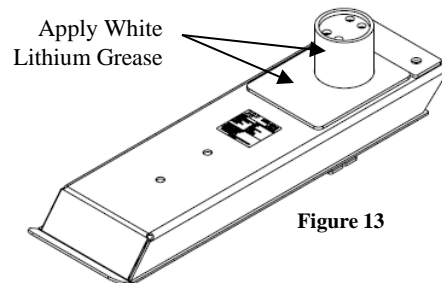

Figure 13

Installation Instructions

19K Sidewinder™

ASSEMBLY INSTRUCTIONS – CON'T

5. Raise the Sidewinder™ arm into position, figure 14. Align the pivot tube on the arm inside of the pivot bushing within the turret. It may be necessary to drive the pivot bushing down while the arm is raised, this may be done with a rubber mallet or a block of wood and a hammer. Support arm in place; install the upper wear disc and outer cap. Install (4) 5/8" Cap bolts & 5/8" Lock washers, do not fully tighten these bolts at this time (figure 15).

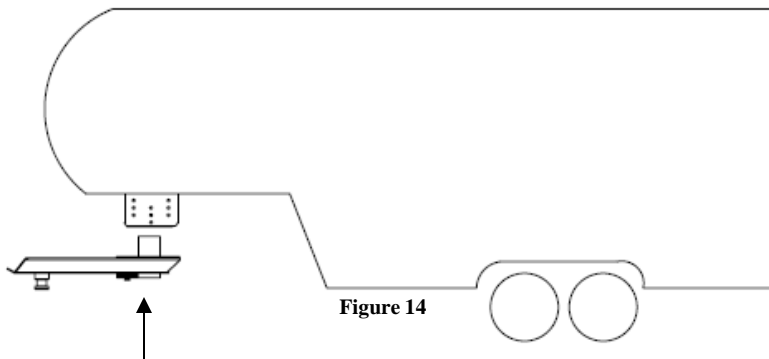

Figure 14

Note: Pivoting the arm while raising into place may ease installation into the turret.

⚠ WARNING: The Sidewinder™ is heavy, take care to maintain adequate support under the Sidewinder™ arm until the (4) cap bolts have been properly installed. Failure to do so may result in death or serious injury.

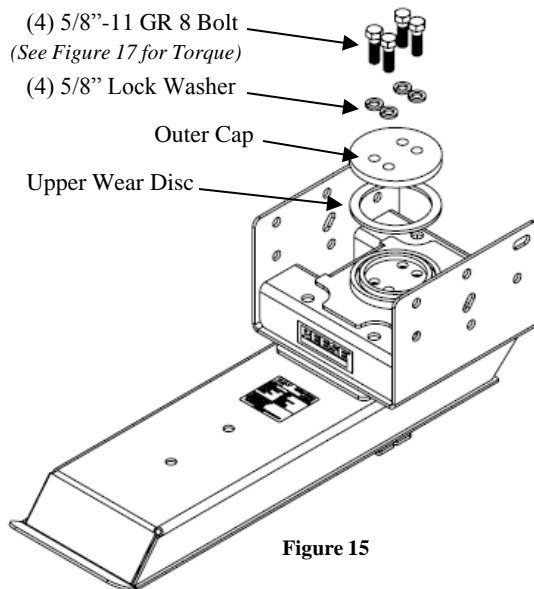

Figure 15

6. Before attempting to fully tighten the (4) 5/8-11 cap bolts, it is necessary to check that the upper wear disc is properly positioned. Refer to the figure below (figure 16).

Upper Wear Disc Must Seat Around the pivot tube of the arm as shown. There should be No Visible Gap.

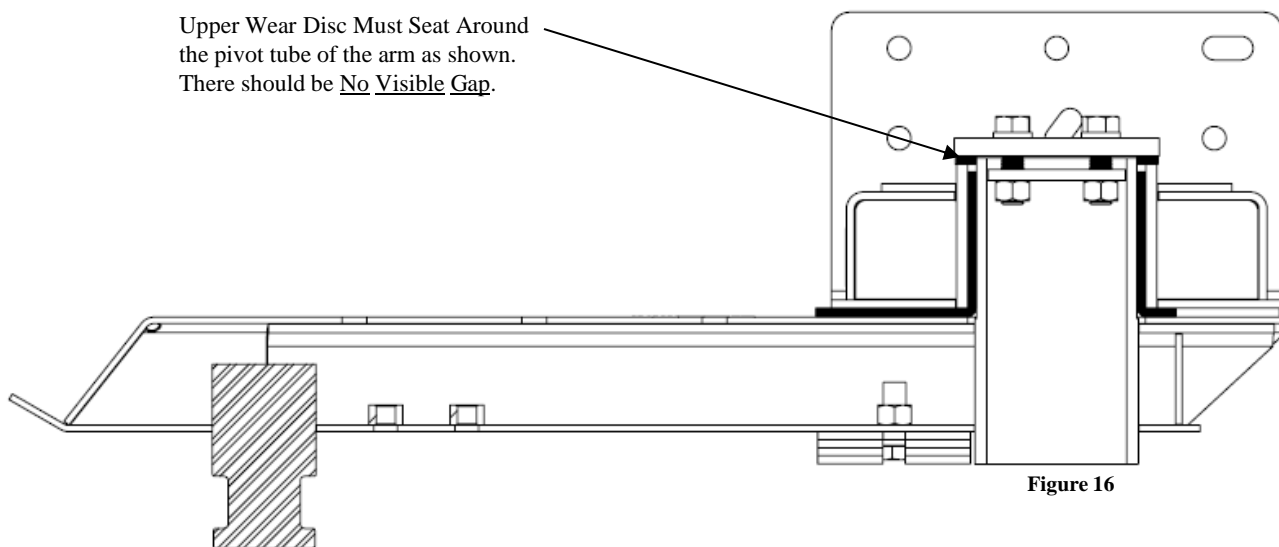

Figure 16

Installation Instructions

19K Sidewinder™

ASSEMBLY INSTRUCTIONS – CON'T

5. Tighten (4) 5/8-11 cap bolts as shown, repeat pattern 2-3 times.

Repeat pattern 2-3 times

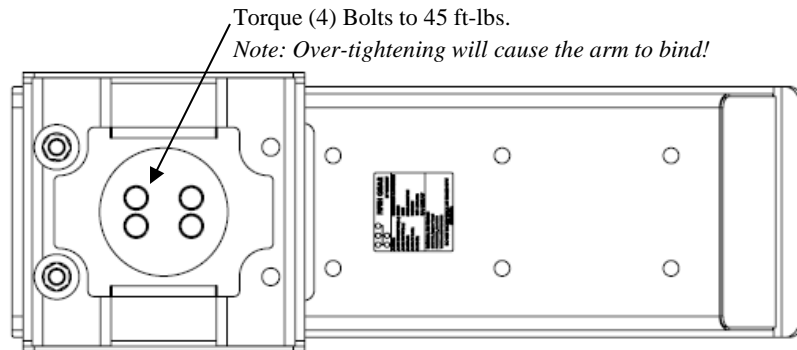
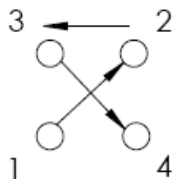
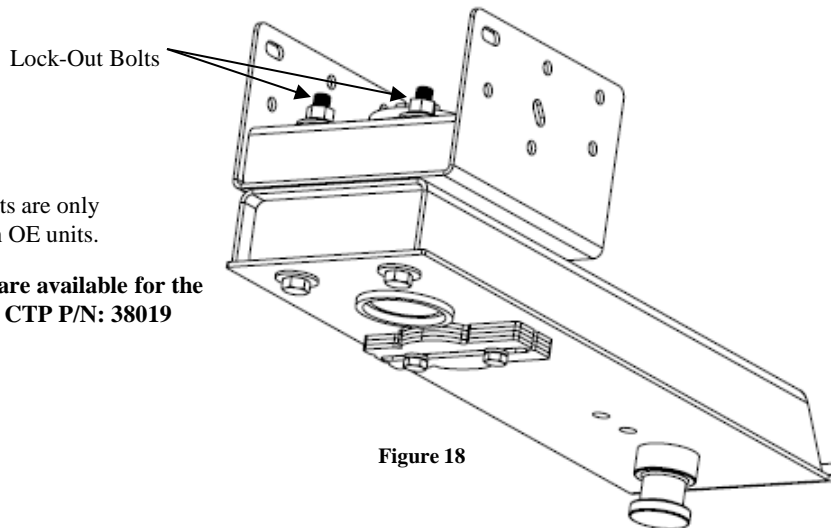

Figure 17

OPERATION INSTRUCTIONS

Conventional Transport:

The Sidewinder™ Pin-Box is very versatile and can be used as a standard pin box – Conventional Transport. For conventional transport (2) 3/4" GR 5 Bolts and Hardware are installed in the back of the unit (figure 18), on OE applications these come installed from the factory and may or may not have been removed by the dealer. The two bolts prevent rotation and allow use of the pin-box without the wedge installed.



Note: Lock Out Bolts are only supplied on OE units.

Lock-Out bolt kits are available for the 19K Sidewinder™ CTP P/N: 38019

Figure 18

Sidewinder™ Transport:

Sidewinder™ Pin-Boxes equipped with lock-out bolts can be converted to activate the Sidewinder™ feature. This feature moves the pivot from the truck bed to the pin-box mounting wings under the nose of the trailer and allows worry free towing up to 90° or more.

⚠ DANGER: Do Not install a wedge without removing the Lock-Out Bolts. Never operate without a wedge if the Lock-Out bolts are not installed. Doing this will create a double pivot and could result in death or serious injury and/or damage to the tow vehicle and trailer.

Installation Instructions

19K Sidewinder™

Activating the Sidewinder™ Feature:

1. Remove (2) 3/4" Lock-Out bolts and hardware from the rear of the pin-box (figure 18).
2. Remove the universal wedge from it's storage location by removing (2) 5/8-11 X 1 3/4" bolts and lock washers.

Note: The universal wedge is supplied with the unit and provides a lockout for many different fifth wheel hitches. Cequent Performance Products offers custom wedges designed for specific fifth wheel hitches, check with your RV dealer or call CPP customer service at 1-888-521-0510 to see if we offer a custom wedge for your hitch application for purchase. If a custom wedge is available for your hitch application, CPP recommends replacing the universal wedge with a custom wedge to provide the best fit for your hitch. The universal wedge should remain with the unit as it may be necessary if breakdown occurs to fit a tow vehicle other than your own.

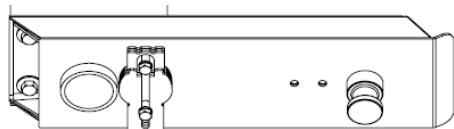

Figure 19

Wedge In Storage Location

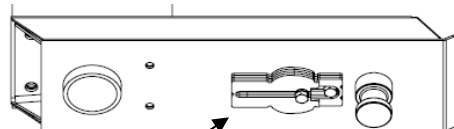

Figure 20

Wedge In Position for Sidewinder™ Feature Activation

Universal Wedge Orientation:

Before installing the universal wedge in position it is necessary to decide the best orientation for your hitch application. This can be done by referencing the diagrams below.

Orientation for Reese/Draw-Tite/Hidden Hitch Select Series, Pro Series, Husky & similar style fifth wheel heads.

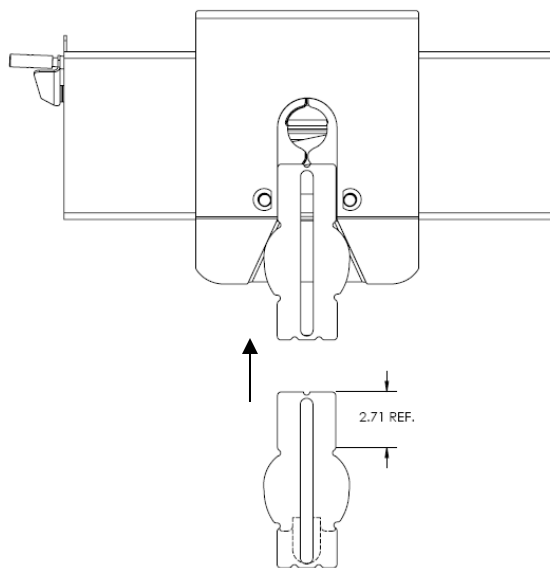

Figure 21

Orientation for Reese/Draw-Tite/Hidden Hitch Signature Series & Select Plus, Reese Titan 16K & 20K, B&W and similar style fifth wheels.

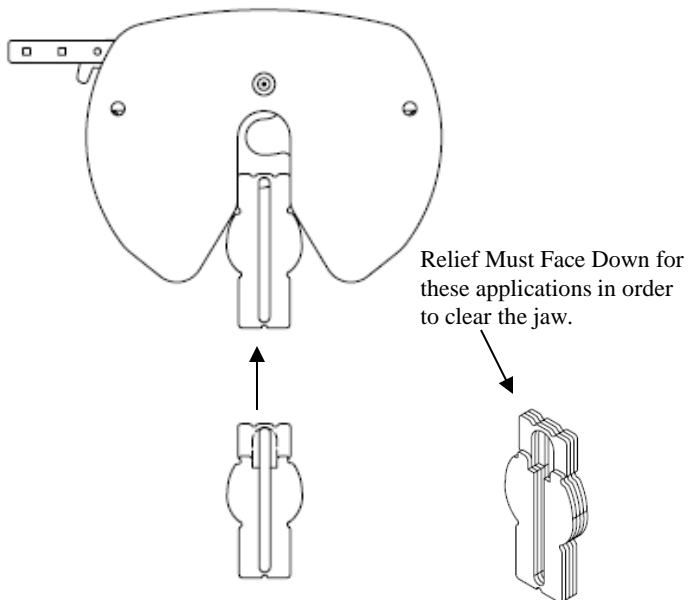

Figure 22

Installation Instructions

19K Sidewinder™

Activating the Sidewinder™ Feature Con't:

3. Install the universal wedge into the position for Sidewinder™ feature activation (figure 20) , in the proper orientation for your fifth wheel. The bolts will not be fully tightened at this time. (figure 23) Only tighten the (2) 5/8-11 X 1 3/4" wedge bolts until the lock washers begin to engage. The wedge should be allowed to slide with the rap of a hammer or mallet.
4. Apply grease to the surface on both sides of the wedge, the back side of the pin, and the skid plate surface as shown in figure 23. **For Signature Series Fifth Wheel Heads, lubricate the area where the jaw passes under the wedge.*

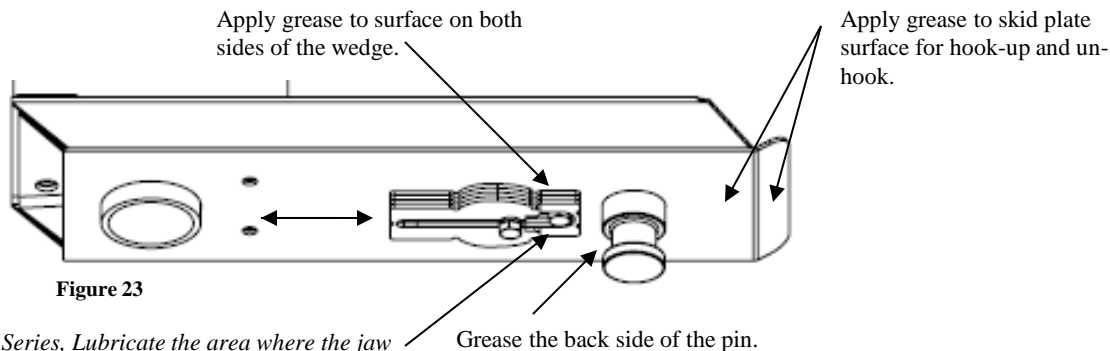

Figure 23

**For Signature Series, Lubricate the area where the jaw passes under the wedge*

5. Hook-up to the fifth wheel trailer following the hitching procedure in this manual, for proper latching of the fifth wheel hitch refer to the owners manual for your fifth wheel hitch.
6. With the trailer wheels still firmly blocked, landing gear still resting firm on the ground and supporting the trailer weight, and truck stationary and in park with the emergency brake on: Tap the wedge firmly forward until it will no longer travel.
7. Attempt to tighten both wedge bolts. Both bolts may not be accessible while the unit is hitched, in these cases tighten the most accessible bolt (usually the rear); these bolts will later be tightened to the proper torque value.
8. Unhitch the trailer from the tow vehicle following the unhitching procedure in this manual.
9. Torque (2) 5/8" Wedge Bolts to 150 ft-lbs (figure 24). A thin walled socket may be necessary.
10. The wedge adjustment is a one time adjustment for your fifth wheel hitch. If a different fifth wheel hitch is used after this adjustment, it is necessary to readjust the wedge for the specific fifth wheel hitch.

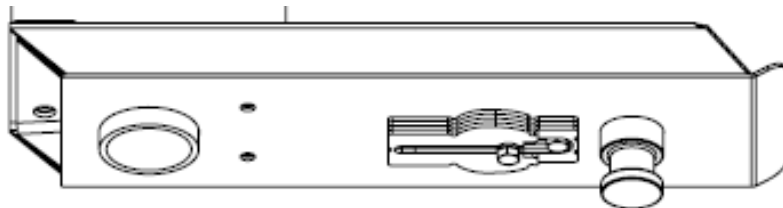

Figure 24

Torque (2) 5/8" Wedge Bolts to 150 ft-lbs.

Installation Instructions

19K Sidewinder™

HITCHING PROCEDURE:

IMPORTANT: YOU ARE RESPONSIBLE FOR SAFE HITCHING AND UNHITCHING OPERATIONS. DO NOT RELY ON OTHERS TO PERFORM THESE DUTIES. YOU MUST PERSONALLY MAKE SURE THE FOLLOWING STEPS ARE PERFORMED IN THE FOLLOWING ORDER!

⚠ WARNING:
FAILURE TO FOLLOW THESE INSTRUCTIONS MAY RESULT IN DEATH OR SERIOUS INJURY.

1. Place blocks (sometimes called “chocks”) firmly against front and rear of each trailer wheel to prevent any possible forward or rearward motion. **DO NOT REMOVE BLOCKS UNTIL EACH OF THE FOLLOWING STEPS AND THE PULL TEST HAVE BEEN COMPLETED.** Lower tailgate if necessary. Clearance of the lowered tailgate to the trailer needs to be monitored during hookups as some manufacturer combinations of truck and trailer have little or no clearance.
2. Using trailer jacks, adjust trailer height following the directions in the trailer manual so that bottom of trailer pin box (“A” in Figure 2) is ½ to 1 inch below skid plate (See “B” in Figure 2). During the hitching maneuver, the bottom of the trailer pin box should come in contact with skid plate ramp (“C” in Figure 2).

Hitch Skid Plate (B)

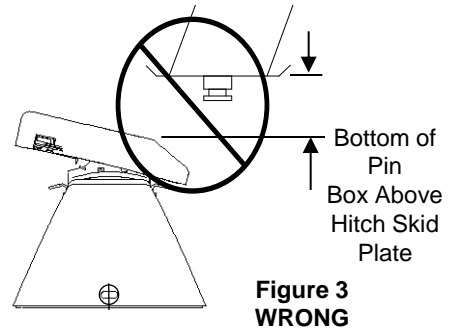
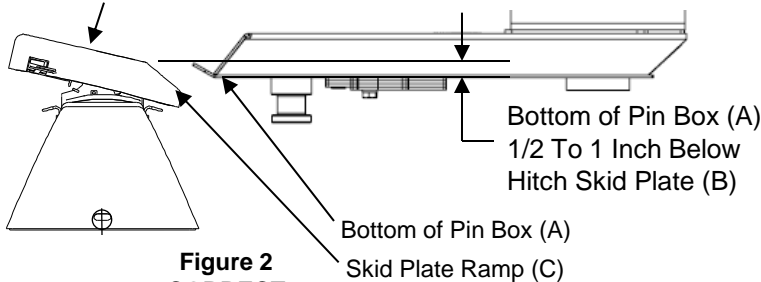

⚠ WARNING:

Failure to follow this instruction may result in king pin being too high and coming to rest on top of closed jaws or not completely inside jaw. (See Fig. 6/7). This could result in trailer separating from hitch. Trailer separation may result in death or serious injury if anyone is under the trailer or between truck and trailer when separation occurs.

3. Open the jaw on the fifth wheel head – refer to the instructions for your fifth wheel head for proper fifth wheel hitch latch operation.
4. Back truck slowly into trailer. Truck and trailer must be straight in-line for the wedge to enter into the fifth wheel funnel.
5. Latch fifth wheel hitch in closed position according to the instructions for your fifth wheel hitch.
5. With all trailer wheels still firmly blocked, landing gear still resting on firm ground and supporting trailer weight, and truck stationary and in park with emergency brake on: visually check that bottom of pin box is resting on top of the hitch. **THERE SHOULD BE NO SPACE BETWEEN THESE SURFACES** (see Figure 6). If space exists, (see Figure 7) trailer has not been properly hitched. **DO NOT TOW!** Instead, repeat above steps until trailer is properly hitched. **DO NOT PLACE BODY UNDER TRAILER TO PERFORM THIS INSPECTION!**

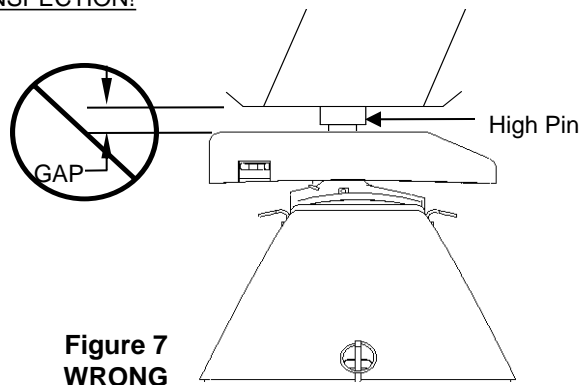
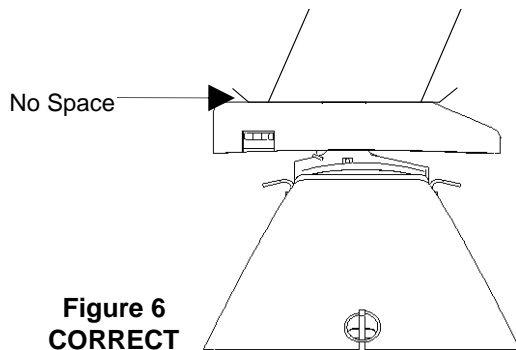

Installation Instructions

19K Sidewinder™

6. With:

- All trailer wheels still firmly blocked in front and behind each tire, and
- Truck stationary with the emergency brake on, and
- Trailer landing gear still resting on firm ground and supporting trailer weight; and
- Truck stationary and with emergency brake on:

Connect electrical cable between truck and trailer, connect breakaway switch cable from pin box to a permanent part of truck, and raise tailgate of truck. Do not tow trailer until the Pull Test has been successfully completed.

⚠ WARNING:

Do not attempt to hitch by using trailer jacks to lower trailer and king pin. This could result in king pin coming to rest on top of skid plate instead of within hitch opening where jaws are located. King pin could slide off hitch and trailer could drop, resulting in death or serious injury (see Figure 9).

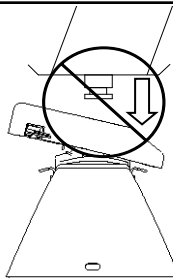

Figure 9
WRONG

⚠ WARNING:

- Connection for trailer wiring should be in the side of the truck bed between the driver's seat and the wheel well for the back truck axle
- Installation of connection rearward of the wheel well may result in user placing body between truck and trailer. **WHENEVER POSSIBLE, AVOID PUTTING BODY UNDER TRAILER OR BETWEEN TRUCK AND TRAILER!**
- If you need to place any part of your body under trailer or between truck and trailer:

- All trailer tires **MUST** be blocked in front and behind each tire **AND**
- Trailer landing gear **MUST** be resting on firm ground **AND**
- Truck **MUST** be stationary, in park, with emergency brake on!

PULL TEST

⚠ WARNING:

Failure to perform pull test may result in death or serious injury

1. With all trailer wheels still firmly blocked, and
2. Trailer landing gear still resting on firm ground and supporting trailer weight and,
3. Truck stationary and with emergency brake on:
4. Make sure no one is between truck and trailer, Return to cab of truck and release truck's emergency brake. Apply trailer brakes. Try to pull trailer slowly forward with the truck. If the trailer is properly hitched, the wheel blocks and trailer brakes should keep the truck from moving forward.

NOTE: If trailer is not properly hitched, trailer will separate from hitch and truck will move forward leaving trailer behind. If you followed all previous steps, the trailer will not drop or fall .

⚠ WARNING:

Failure to keep wheels blocked and landing gear down could result in trailer suddenly moving or falling. This could result in death or serious injury!

5. After successfully performing above steps, fully raise trailer landing gear (see trailer manual).
6. Check and inspect all electrical circuits for proper operation. (Clearance lights, turn signals, stop lights, etc.).
7. Remove and store all trailer wheel blocks.

Installation Instructions

19K Sidewinder™

PERFORM THE FOLLOWING IN THIS ORDER:

1. Make sure truck is in park with emergency brake on.
2. Place blocks firmly against front and rear of each trailer wheel to prevent any possible forward or rearward motion.
3. Using trailer jacks, lower trailer landing gear following the directions in the Trailer Manual until feet of landing gear are resting on firm ground.

WARNING:

Trailers that are not stable or properly hitched can fall and cause death or serious injury!
To avoid death or serious injury:

- All trailer tires **MUST** be blocked in front and behind each tire **AND**
- Trailer landing gear **MUST** be resting on firm ground **AND**
- Truck **MUST** be stationary, in park, with emergency brake on!

4. Lower truck tail gate.
5. Disconnect power cable and breakaway switch cable between truck and trailer.
6. Remove bail pin from hole in handle.
7. Pull hitch handle out completely until it latches in open position so that king pin is no longer securely grasped by hitch jaws. Trailer is now free from hitch and truck. If handle does not pull out, there is probably pressure against the jaw. To relieve this pressure, back the truck slightly. Reset truck emergency brake. Then pull hitch handle out completely until it latches in open position.
8. AFTER MAKING CERTAIN NO ONE IS STANDING BETWEEN TRUCK AND TRAILER OR IN FRONT OF TRUCK, drive truck slowly away from trailer.

WARNING

Whenever possible, avoid putting body under trailer or between truck and trailer
If you need to place any part of our body under trailer or between truck and trailer:

- All trailer tires **MUST** be blocked in front and behind each tire **AND**
- Trailer landing gear **MUST** be resting on firm ground **AND**
- Truck **MUST** be stationary, in park, with emergency brake on!

9. Hitch jaw will automatically close as the king pin is removed from the jaw.
10. KEEP WHEEL BLOCKS IN PLACE. This will keep trailer from moving unexpectedly

BEFORE EACH TRIP:

1. CHECK YOUR EQUIPMENT: Check that condition of all of your towing equipment and keep it in top condition.
2. Check that the torque of the (4) cap bolts is 45 ft-lbs, refer to figures 16 & 17 in this manual.
3. Check to see that all bolts are properly tightened.
4. Check wedge engagement in the fifth wheel jaw, refer to wedge adjustment portion of this manual.

MAINTENANCE:

1. For ease of hookup; frequently lubricate the wedge surfaces, back side of the king pin, and the skid plate surface.
2. If resistance is present in the Sidewinder™ arm, apply a lithium grease to the bearing surfaces as described in the assembly section of this manual.
3. Keep pin-box hitch painted to prevent rust and maintain a good appearance. (Do Not paint over labels)

