



# Installation Guide and Product Specifications



## CSI REFRIGERATOR/FREEZER SLIDE PART#W57 AND #W58

**IMPORTANT**  
**Read instructions before operation**

SECTION	PAGE
Safety Instructions	2
Installation	3
Technical Specifications	4

**PLEASE READ ALL INSTRUCTIONS AND THE SAFETY SECTION CAREFULLY BEFORE USING YOUR REFRIGERATOR/FREEZER SLIDE. KEEP THESE INSTRUCTIONS FOR FUTURE REFERENCE.**

**PART#W57 Vehicle Mount with slide for #W53 Refrigerator/Freezer**  
**PART#W58 Vehicle Mount with slide for #W55 Refrigerator/Freezer**

**What's Included in the box:**

- x1 #W57 or #W58 Refrigerator/Freezer Slide
- x4 Tie-down Straps
- Installation Hardware and Instructions

**Key Product Features:**

- Metal Powder coated construction
- Universal installation. Includes mounting hardware
- Mounts #W53/#W55 refrigerator/freezer securely while allowing drawer type sliding access to the entire refrigerator/freezer for easier access
- 100% extension
- Quick release tie-down straps included
- Quick release thumb latch with additional safety latch

**1. SAFETY INSTRUCTIONS**

- Do not allow children to play on or near the slide
- Do not stand, sit or lay down on the slide
- Do not operate the slide if it is visibly damaged
- Do not place fingers or other body parts in or around the slide rails
- Only use the tightening straps as instructed
- Do not install or use the slide on an uneven surface
- Do not use the slide without properly fixing it to the vehicle
- Do not leave the slide unlocked

## PART#W57/#W58 VEHICLE MOUNT WITH SLIDE FOR REFRIGERATOR/FREEZER

### Installation Instruction:

1. Mount the slide to a solid surface, press the lock and pull slide to the middle to access mounting holes
2. Use a minimum of 4 mounting holes
3. Tighten all fasteners
4. Verify slide operation and that the slide is mounted securely to avoid refrigerator from tipping before installing refrigerator

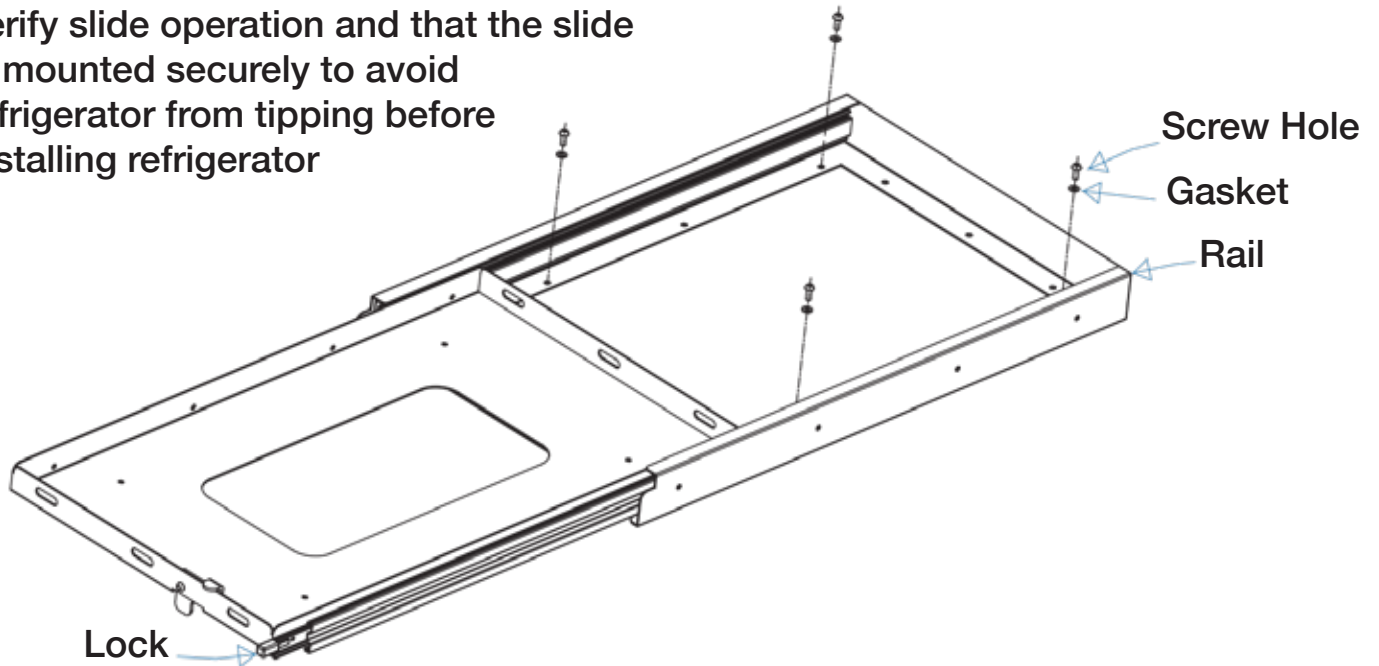

1. The slide must be mounted to a solid surface before using
2. Fix the refrigerator on the slide rail and attach matching tightening straps before use.

Tightening straps



**PART#W57**  
**VEHICLE MOUNT WITH SLIDE**  
**FOR REFRIGERATOR/FREEZER**  
**DIMENSIONS**

① Slide Dimension: 31"L x 18"W x 2.5"H

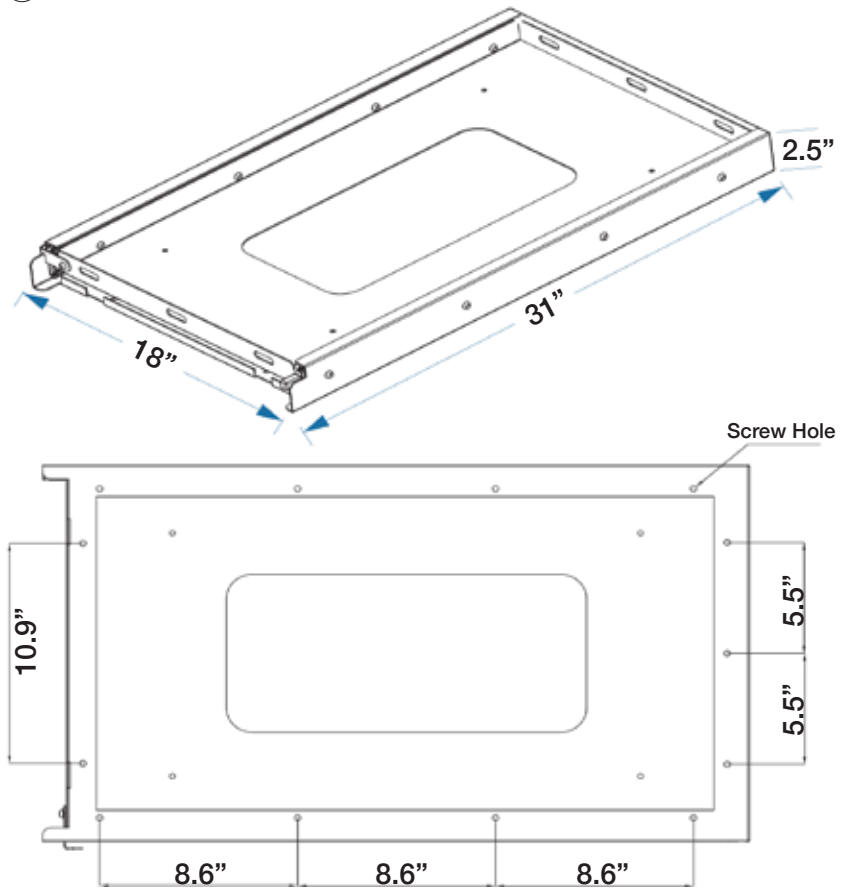

**PART#W58**  
**VEHICLE MOUNT WITH SLIDE**  
**FOR REFRIGERATOR/FREEZER**  
**DIMENSIONS**

② Slide Dimension: 37"L x 23.5"W x 2.5"H

