

Non-solid Al - electrolytic capacitors

Axial Standard, High Voltage

ASH 041 - 043

FEATURES

- Polarized aluminium electrolytic capacitors, non-solid
- Axial leads, cylindrical aluminium case, insulated with a blue sleeve
- Mounting ring version (single ended) not insulated
- Case $\varnothing 10 \times 30$ to 21×40 mm with pressure relief
- Taped versions up to case $\varnothing 15 \times 30$ mm available for automatic insertion
- Charge and discharge proof
- Useful life: 5000 to 15000 hours at 85 °C
- High rated voltage: up to 450 V.

APPLICATIONS

- General purpose, industrial, power supply, audio-video and lighting
- Smoothing, filtering, buffering at high voltages
- Boards with restricted mounting height, vibration and shock resistant.

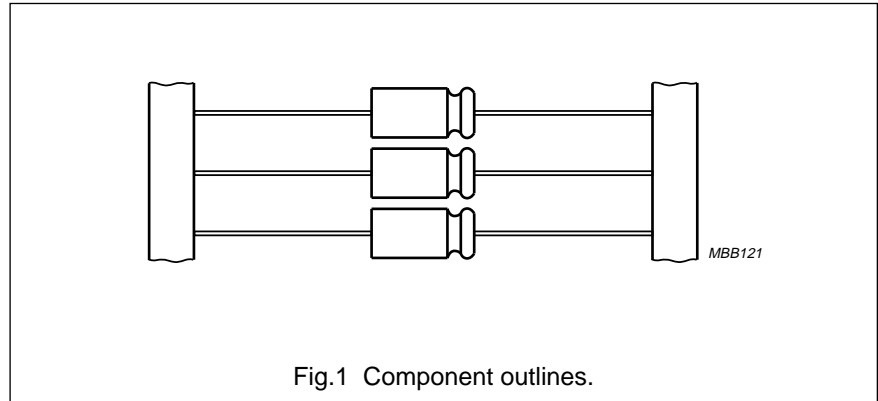
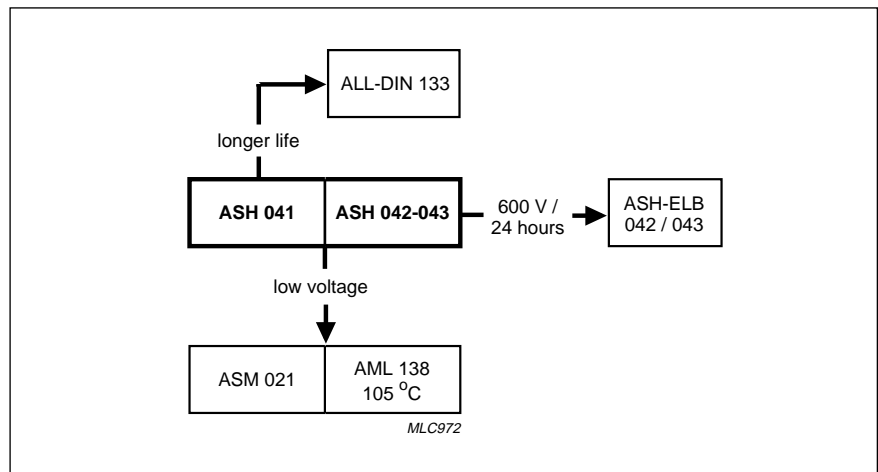

Fig.1 Component outlines.



QUICK REFERENCE DATA

DESCRIPTION	VALUE	
Case sizes ($\varnothing D_{nom} \times L_{nom}$ in mm)	6.5 × 18 to 10 × 25	10 × 30 to 21 × 40
Rated capacitance range, C_R	1 to 220 μF	
Tolerance on C_R	-10 to +50%	
Rated voltage range, U_R	160 to 450 V	
Category temperature range	-40 to +85 °C (450 V: -25 to +85 °C)	
Endurance test at 85 °C	2000 hours	8000 hours; 450 V: 2000 hours
Useful life at 85 °C	5000 hours	15000 hours; 450 V: 5000 hours
Useful life at 40 °C	1.4 × I_R applied: 120000 hours	1.8 × I_R applied: 240000 hours; 450 V: 120000 hours
Shelf life at 0 V, 85 °C	500 hours	500 hours
Based on sectional specification	IEC 384-4/CECC 30300, LL grade	
Climatic category IEC 68 (DIN 40040)	40/085/56 (450 V: 25/085/56); GPF (450 V: HPF)	

Non-solid Al - electrolytic capacitors Axial Standard, High Voltage

ASH 041 - 043

Selection chart for C_R , U_R and relevant nominal case sizes ($\varnothing D \times L$ in mm)

Preferred types in **bold**.

C_R (μF)	U_R (V)					
	160	250	350	385	400	450
1.0	–	–	–	6.5 × 18	–	–
2.2	–	6.5 × 18	–	8 × 18	–	–
4.7	6.5 × 18	8 × 18	10 × 18	10 × 25	–	–
6.8	–	–	10 × 30	10 × 30	10 × 30	10 × 30
10	8 × 18	10 × 25	12.5 × 30	12.5 × 30	12.5 × 30	12.5 × 30
	–	10 × 30	–	–	–	–
15	–	12.5 × 30	12.5 × 30	15 × 30	15 × 30	12.5 × 30
22	10 × 25	12.5 × 30	15 × 30	18 × 30	18 × 30	15 × 30
	10 × 30	–	–	–	–	–
33	12.5 × 30	15 × 30	18 × 30	18 × 40	18 × 40	18 × 30
47	15 × 30	18 × 30	18 × 40	18 × 40	18 × 40	18 × 40
68	15 × 30	18 × 40	21 × 40	21 × 40	21 × 40	21 × 40
100	18 × 30	21 × 40	–	–	–	–
150	18 × 40	–	–	–	–	–
220	21 × 40	–	–	–	–	–

MARKING

The capacitors are marked (where possible) with the following information:

- Rated capacitance (in μF)
- Tolerance on rated capacitance, code letter in accordance with "IEC 62"
- Rated voltage (in V)
- Group number (041, 042 or 043)
- Name of manufacturer (PHILIPS)
- Date code, in accordance with "IEC 62"
- Code indicating factory of origin
- Band to identify the negative terminal
- "+" sign to indicate the positive terminal.

Non-solid Al - electrolytic capacitors
Axial Standard, High Voltage

ASH 041 - 043

MECHANICAL DATA, AVAILABLE FORMS AND PACKAGING QUANTITIES

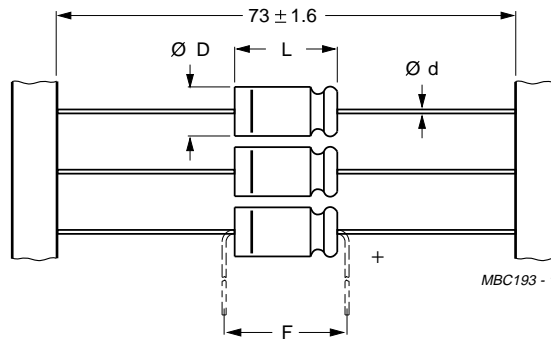

Dimensions in mm.

Form BR: Taped on reel,
case $\varnothing D \times L = 6.5 \times 18$ to 15×30 mm.

Form BA: Taped in box (ammopack),
case $\varnothing D \times L = 6.5 \times 18$ to 10×25 mm.

For dimensions see Table 1.

Tape dimensions are specified in this handbook, section "Packaging".

Fig.2 Dimensional outline; Forms BA and BR.

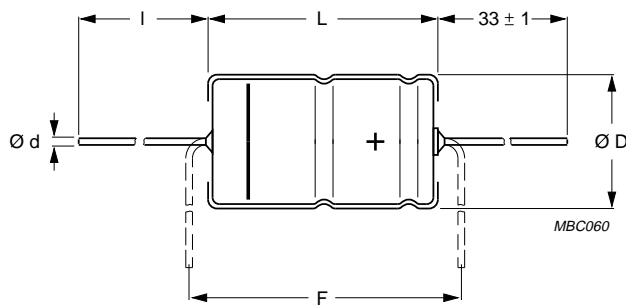

Dimensions in mm.

Form AA: Axial in box,
case $\varnothing D \times L = 10 \times 30$ to 21×40 mm

For dimensions see Table 1.

Tape dimensions are specified in this handbook, section "Packaging".

For case sizes 18×40 mm and 21×40 mm, the stated L may be exceeded by 0.7 mm.

Fig.3 Dimensional outline; Form AA.

Non-solid Al - electrolytic capacitors
Axial Standard, High Voltage

ASH 041 - 043

Table 1 Axial; physical dimensions, mass and packaging information; see Figs 2 and 3

NOMINAL CASE SIZE ØD × L (mm)	CASE CODE	AXIAL: FORM AA, BA, and BR					MASS (g)	PACKAGING QUANTITIES		
		Ød (mm)	l (mm)	ØD _{max} (mm)	L _{max} (mm)	F _{min} (mm)		FORM AA	FORM BA	FORM BR
6.5 × 18	4	0.8	–	6.9	18.5	25	≈1.3	–	1000	1000
8 × 18	5	0.8	–	8.5	18.5	25	≈1.7	–	500	500
10 × 18	6	0.8	–	10.5	18.5	25	≈2.5	–	500	500
10 × 25	7	0.8	–	10.5	25.0	30	≈3.3	–	500	500
10 × 30	00	0.8	55 ±1	10.5	30.5	35	≈4.8	200	–	500
12.5 × 30	01	0.8	55 ±1	13.0	30.5	35	≈7.4	200	–	400
15 × 30	02	0.8	55 ±1	15.5	30.5	35	≈11.7	200	–	250
18 × 30	03	0.8	55 ±1	18.5	30.5	35	≈12.9	200	–	–
18 × 40	04	0.8	34 ±1	18.5	41.5	45	≈19.4	100	–	–
21 × 40	05	0.8	34 ±1	21.5	41.5	45	≈24.7	100	–	–

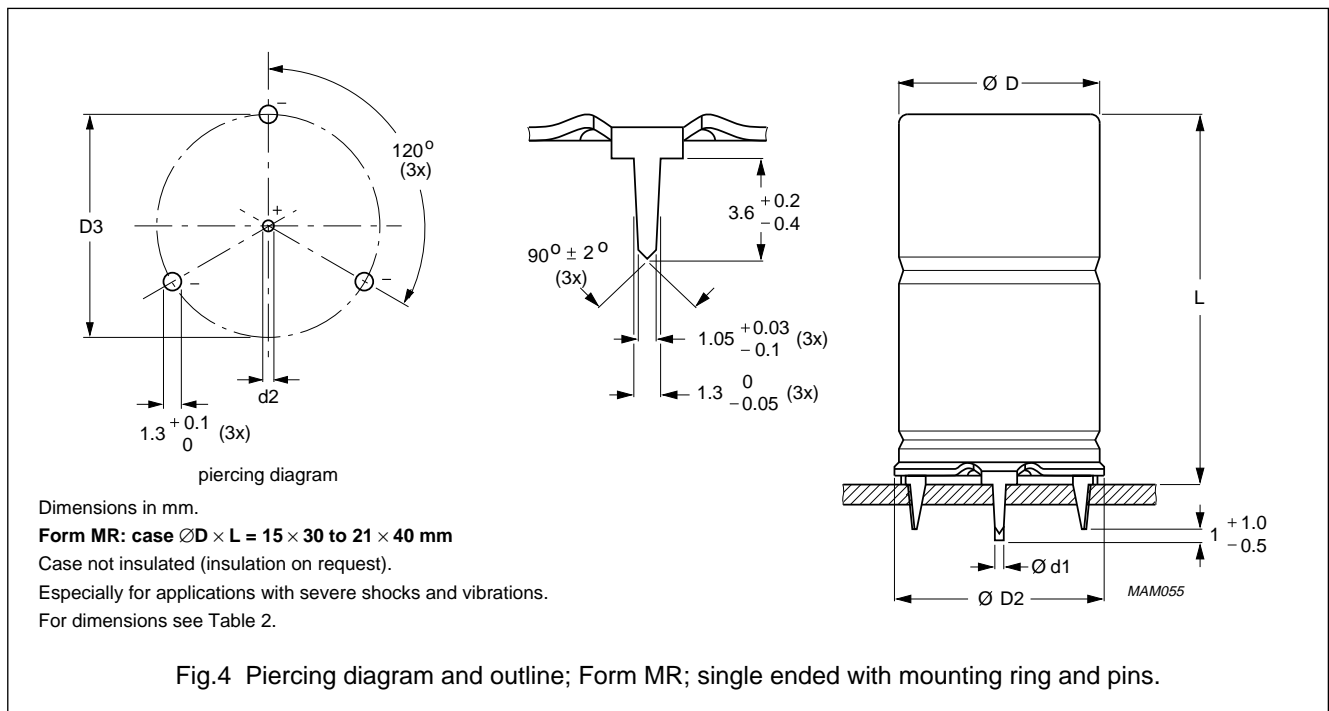

Table 2 Single ended; physical dimensions, mass and packaging information; see Fig.4

NOMINAL CASE SIZE ØD × L (mm)	CASE CODE	SINGLE ENDED WITH MOUNTING RING: FORM MR						MASS (g)	PACKAGING QUANTITIES
		ØD ₁ (mm)	ØD ₂ (mm)	ØD _{max} (mm)	ØD _{2max} (mm)	D3 (mm)	L _{max} (mm)		
15 × 30	02	0.8	1.0 +0.4	15.5	17.5	16.5 ±0.2	33	≈11.7	200
18 × 30	03	0.8	1.0 +0.4	18.5	19.5	18.5 ±0.2	33	≈12.9	200
18 × 40	04	0.8	1.0 +0.4	18.5	19.5	18.5 ±0.2	45	≈19.4	100
21 × 40	05	0.8	1.0 +0.4	21.5	22.5	21.5 ±0.2	45	≈24.7	100

Non-solid Al - electrolytic capacitors
Axial Standard, High Voltage

ASH 041 - 043

Ordering example

Electrolytic capacitor ASH 041

10 μ F/250 V; -10/+50%

Nominal case size: \varnothing 10 \times 25 mm; Form BA

Catalogue number: 2222 041 33109.

ELECTRICAL DATA AND ORDERING INFORMATION

Unless otherwise specified, all electrical values in Table 3 apply at $T_{amb} = 20\text{ }^{\circ}\text{C}$,
P = 86 to 106 kPa, RH = 45 to 75%.

SYMBOL	DESCRIPTION
C_R	rated capacitance at 100 Hz, tolerance -10 to +50%
I_R	rated RMS ripple current at 100 Hz, 85 $^{\circ}\text{C}$
I_{L1}	max. leakage current after 1 minute at U_R
I_{L5}	max. leakage current after 5 minutes at U_R
Tan δ	max. dissipation factor at 100 Hz
ESR	equivalent series resistance at 100 Hz (calculated from tan δ_{max} and C_R)
Z	max. impedance at 10 kHz

Table 3 Electrical data and ordering information; preferred types in **bold**

U_R (V)	C_R 100 Hz (μ F)	NOMINAL CASE SIZE $\varnothing D \times L$ (mm)	CASE CODE	I_R 100 Hz 85 $^{\circ}\text{C}$ (mA)	I_{L1} 1 min (μ A)	I_{L5} 5 min (μ A)	Tan δ 100 Hz	ESR 100 Hz (Ω)	Z 10 kHz (Ω)	CATALOGUE NUMBER 2222			
										AXIAL			SINGLE ENDED
										IN BOX FORM AA	TAPED ON REEL FORM BR	TAPED IN BOX FORM BA	MOUNTING RING FORM MR
160	4.7	6.5 \times 18	4	50	38	8	0.15	51	26	-	041 21478	041 31478	-
	10	8 \times 18	5	70	68	14	0.15	24	12	-	041 21109	041 31109	-
	22	10 \times 25	7	150	130	25	0.15	11	5.5	-	041 21229	041 31229	-
	22	10 \times 30	00	120	42	25	0.10	6.8	5.5	042 11229	042 21229	-	-
	33	12.5 \times 30	01	150	58	36	0.10	4.5	3.1	042 11339	042 21339	-	-
	47	15 \times 30	02	190	78	49	0.10	3.2	2.1	042 11479	042 21479	-	042 41479
	68	15 \times 30	02	230	110	69	0.10	2.2	1.4	042 11689	042 21689	-	042 41689
	100	18 \times 30	03	350	150	100	0.10	1.5	1.0	042 11101	-	-	042 41101
	150	18 \times 40	04	430	230	150	0.10	1.0	0.7	043 11151	-	-	043 41151
	220	21 \times 40	05	610	330	220	0.10	0.7	0.5	043 11221	-	-	043 41221
250	2.2	6.5 \times 18	4	35	28	6	0.10	72	50	-	041 23228	041 33228	-
	4.7	8 \times 18	5	55	55	11	0.10	34	23	-	041 23478	041 33478	-
	10	10 \times 25	7	90	95	19	0.10	16	11	-	041 23109	041 33109	-
	10	10 \times 30	00	72	33	19	0.10	15	11	042 13109	042 23109	-	-

Non-solid Al - electrolytic capacitors
Axial Standard, High Voltage

ASH 041 - 043

U _R (V)	C _R 100 Hz (μF)	NOMINAL CASE SIZE ØD × L (mm)	CASE CODE	I _R 100 Hz 85 °C (mA)	I _{L1} 1 min (μA)	I _{L5} 5 min (μA)	Tan δ 100 Hz	ESR 100 Hz (Ω)	Z 10 kHz (Ω)	CATALOGUE NUMBER 2222			
										AXIAL			SINGLE ENDED
										IN BOX FORM AA	TAPED ON REEL FORM BR	TAPED IN BOX FORM BA	MOUNTING RING FORM MR
250	15	12.5 × 30	01	100	44	27	0.10	10	7.4	042 13159	042 23159	–	–
	22	12.5 × 30	01	130	60	37	0.10	6.8	5.0	042 13229	042 23229	–	–
	33	15 × 30	02	160	84	54	0.10	4.5	3.4	042 13339	042 23339	–	042 43339
	47	18 × 30	03	220	120	75	0.10	3.2	2.3	042 13479	–	–	042 43479
	68	18 × 40	04	290	160	110	0.10	2.2	1.7	043 13689	–	–	043 43689
	100	21 × 40	05	390	240	150	0.10	1.5	1.1	043 13101	–	–	043 43101
350	4.7	10 × 18	6	60	69	14	0.10	34	22	–	041 25478	041 35478	–
	6.8	10 × 30	00	60	32	18	0.10	22	14	042 15688	042 25688	–	–
	10	12.5 × 30	01	90	42	25	0.10	15	10	042 15109	042 25109	–	–
	15	12.5 × 30	01	100	57	36	0.10	10	6.7	042 15159	042 25159	–	–
	22	15 × 30	02	140	79	50	0.10	6.8	4.5	042 15229	042 25229	–	042 45229
	33	18 × 30	03	160	110	73	0.10	4.5	3.1	042 15339	–	–	042 45339
	47	18 × 40	04	270	160	100	0.10	3.2	2.1	043 15479	–	–	043 45479
	68	21 × 40	05	320	220	150	0.10	2.2	1.4	043 15689	–	–	043 45689
385	1	6.5 × 18	4	20	19	4	0.10	160	100	–	041 28108	041 38108	–
	2.2	8 × 18	5	40	42	8	0.10	72	45	–	041 28228	041 38228	–
	4.7	10 × 25	7	70	71	15	0.10	34	22	–	041 28478	041 38478	–
	6.8	10 × 30	00	60	34	20	0.10	22	14	042 18688	042 28688	–	–
	10	12.5 × 30	01	90	45	27	0.10	15	10	042 18109	042 28109	–	–
	15	15 × 30	02	110	62	39	0.10	10	6.0	042 18159	042 28159	–	042 48159
	22	18 × 30	03	150	86	55	0.10	6.8	4.1	042 18229	–	–	042 48229
	33	18 × 40	04	200	120	80	0.10	4.5	2.7	043 18339	–	–	043 48339
	47	18 × 40	04	270	170	110	0.10	3.2	2.1	043 18479	–	–	043 48479
	68	21 × 40	05	320	250	160	0.10	2.2	1.4	043 18689	–	–	043 48689

Non-solid Al - electrolytic capacitors
Axial Standard, High Voltage

ASH 041 - 043

U_R (V)	C_R 100 Hz (μ F)	NOMINAL CASE SIZE $\varnothing D \times L$ (mm)	CASE CODE	I_R 100 Hz 85 °C (mA)	I_{L1} 1 min (μ A)	I_{L5} 5 min (μ A)	Tan δ 100 Hz	ESR 100 Hz (Ω)	Z 10 kHz (Ω)	CATALOGUE NUMBER 2222			
										AXIAL			SINGLE ENDED
										IN BOX FORM AA	TAPED ON REEL FORM BR	TAPED IN BOX FORM BA	MOUNTING RING FORM MR
400	6.8	10 × 30	00	82	220	110	0.055	11.5	7.3	042 16688	042 26688	-	-
	10	12.5 × 30	01	130	240	110	0.055	7.5	4.6	042 16109	042 26109	-	-
	15	15 × 30	02	160	250	110	0.055	5.0	3.1	042 16159	042 26159	-	042 46159
	22	18 × 30	03	210	280	120	0.055	3.5	2.1	042 16229	-	-	042 46229
	33	18 × 40	04	290	320	130	0.055	2.3	1.4	043 16339	-	-	043 46339
	47	18 × 40	04	330	370	140	0.055	1.7	1.1	043 16479	-	-	043 46479
	68	21 × 40	05	430	440	150	0.055	1.2	0.7	043 16689	-	-	043 46689
450	6.8	10 × 30	00	60	230	110	0.10	22	14	042 17688	042 27688	-	-
	10	12.5 × 30	01	90	240	110	0.10	15	10	042 17109	042 27109	-	-
	15	12.5 × 30	01	100	260	110	0.10	10	6	042 17159	042 27159	-	-
	22	15 × 30	02	140	290	120	0.10	6.8	4.1	042 17229	042 27229	-	042 47229
	33	18 × 30	03	190	330	130	0.10	4.5	2.7	042 17339	-	-	042 47339
	47	18 × 40	04	250	390	140	0.10	3.2	2.1	043 17479	-	-	043 47479
	68	21 × 40	05	330	460	160	0.10	2.2	1.4	043 17689	-	-	043 47689

Non-solid Al - electrolytic capacitors

Axial Standard, High Voltage

ASH 041 - 043

Additional electrical data

PARAMETER	CONDITIONS	VALUE	
		AXIAL	SINGLE ENDED
Voltage			
Surge voltage for short periods	$U_R = 160$ to 250 V	$U_s \leq 1.15 \times U_R$	
	$U_R = 350$ to 450 V	$U_s \leq 1.1 \times U_R$	
Reverse voltage		$U_{rev} \leq 1$ V	
Current			
Leakage current	after 1 minute: case $\varnothing D \times L = 6.5 \times 18$ to 10×25 mm $CV \leq 1000 \mu C$ $CV > 1000 \mu C$ case $\varnothing D \times L = 10 \times 30$ to 21×40 mm $U_R = 160$ to 385 V $U_R = 400$ and 450 V	$I_{L1} \leq 0.05C_R \times U_R$ or $5 \mu A$, whichever is greater $I_{L1} \leq 0.03C_R \times U_R + 20 \mu A$	
	after 5 minutes: $U_R = 160$ to 385 V $CV \leq 1000 \mu C$ $CV > 1000 \mu C$ $U_R = 400$ and 450 V	$I_{L5} \leq 0.01C_R \times U_R$ or $1 \mu A$, whichever is greater $I_{L5} \leq 0.006C_R \times U_R + 4 \mu A$ $I_{L5} \leq 0.002C_R \times U_R + 100 \mu A$	
Inductance			
Equivalent series inductance (ESL)	case $\varnothing D \times L$ mm:		
	6.5×18	typ. 15 nH	–
	8×18	typ. 35 nH	–
	10×18	typ. 69 nH	–
	10×25	typ. 38 nH	–
	10×30	typ. 38 nH	–
	12.5×30	typ. 46 nH	–
	15×30	typ. 48 nH	typ. 39 nH
	18×30	typ. 50 nH	typ. 39 nH
18×40	typ. 54 nH	typ. 39 nH	
21×40	typ. 59 nH	typ. 39 nH	

Non-solid Al - electrolytic capacitors
Axial Standard, High Voltage

ASH 041 - 043

Capacitance (C)

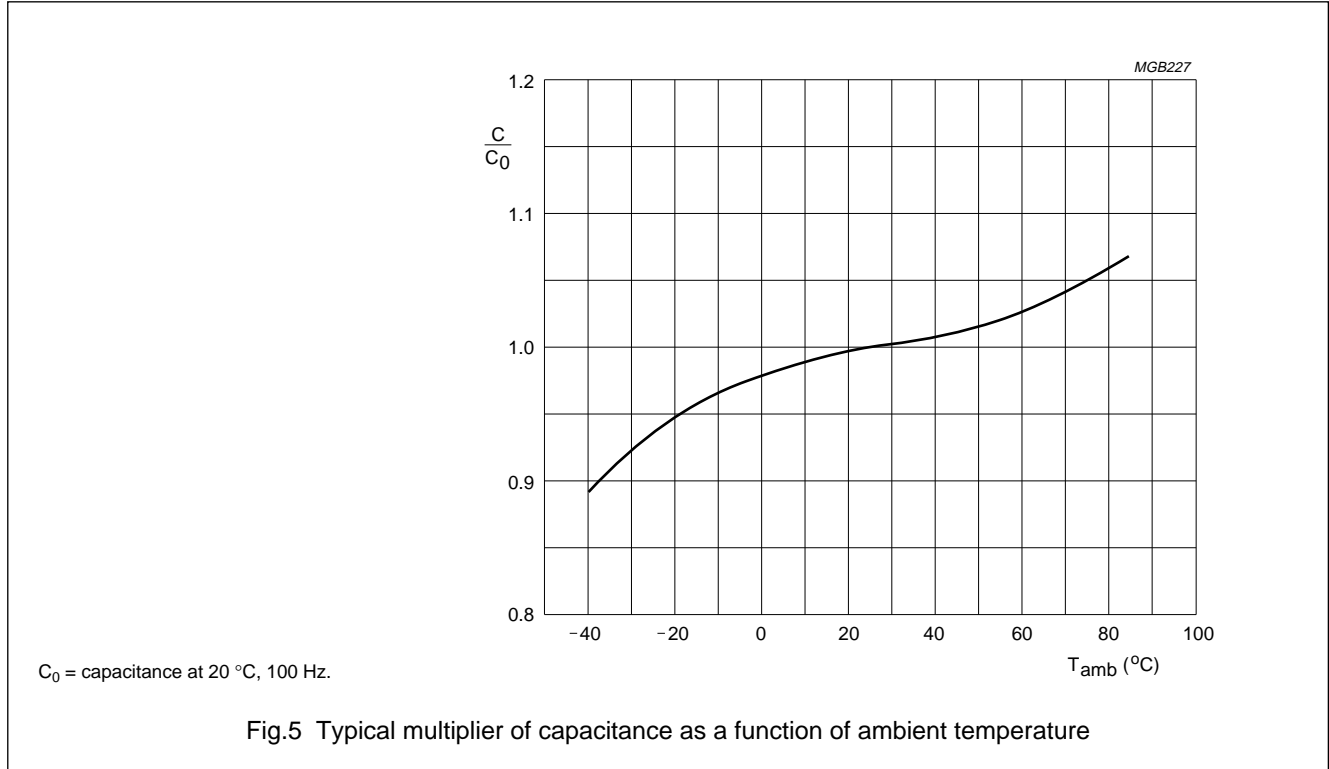

Equivalent series resistance (ESR)

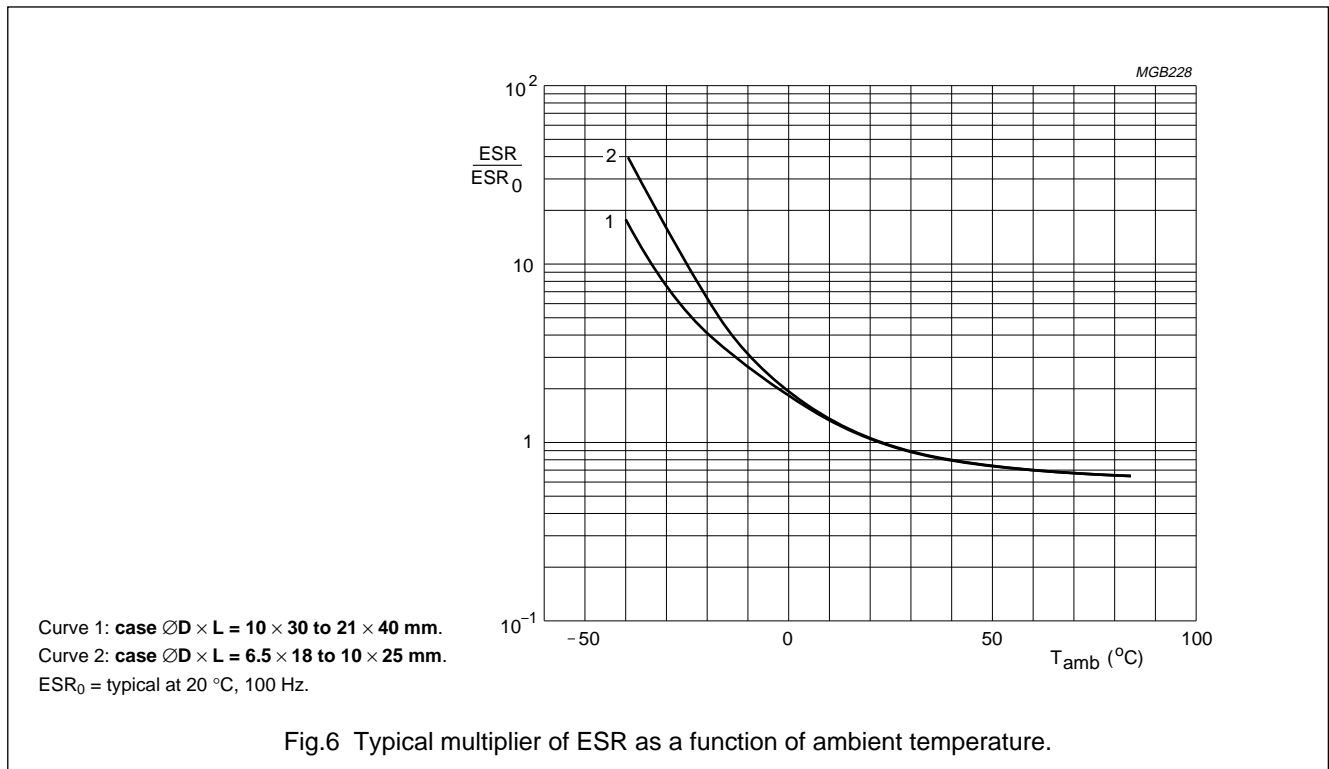

Non-solid Al - electrolytic capacitors
Axial Standard, High Voltage

ASH 041 - 043

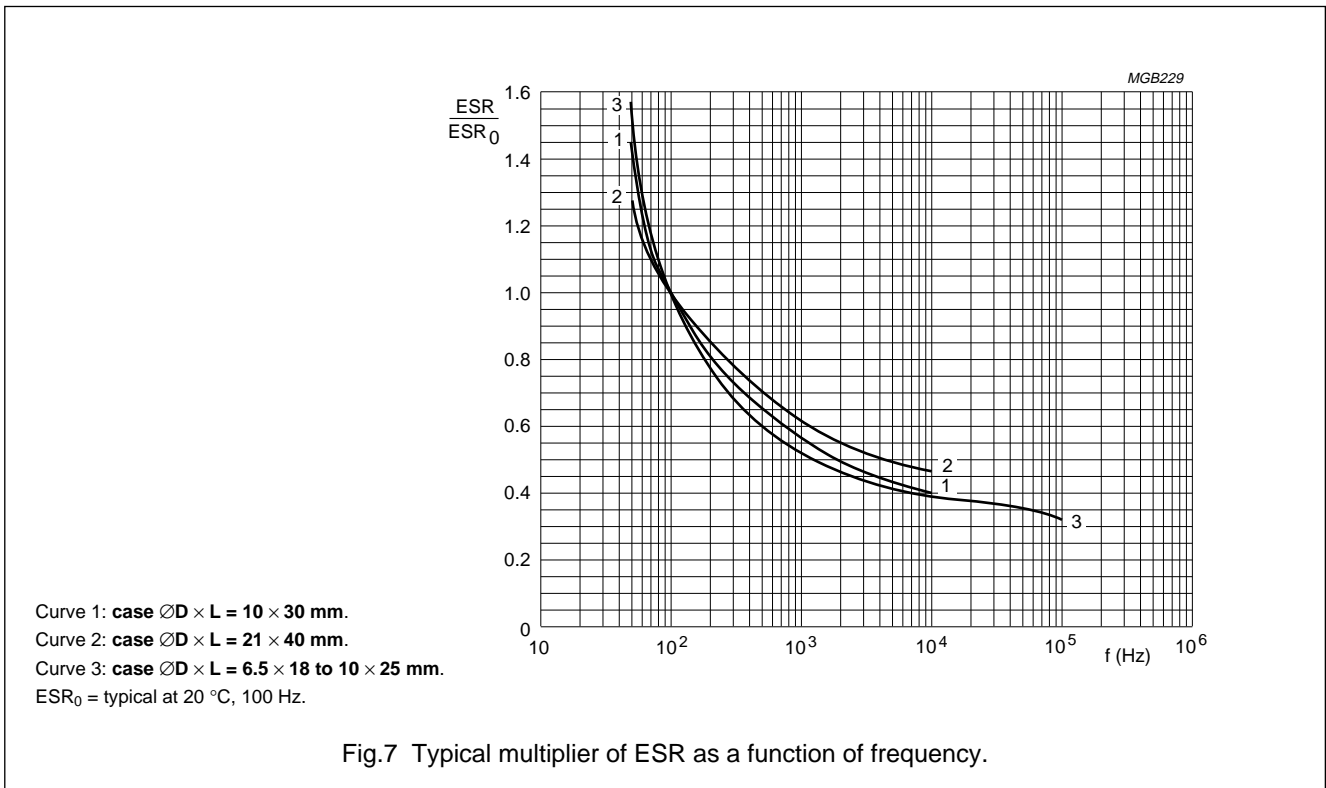

Impedance (Z)

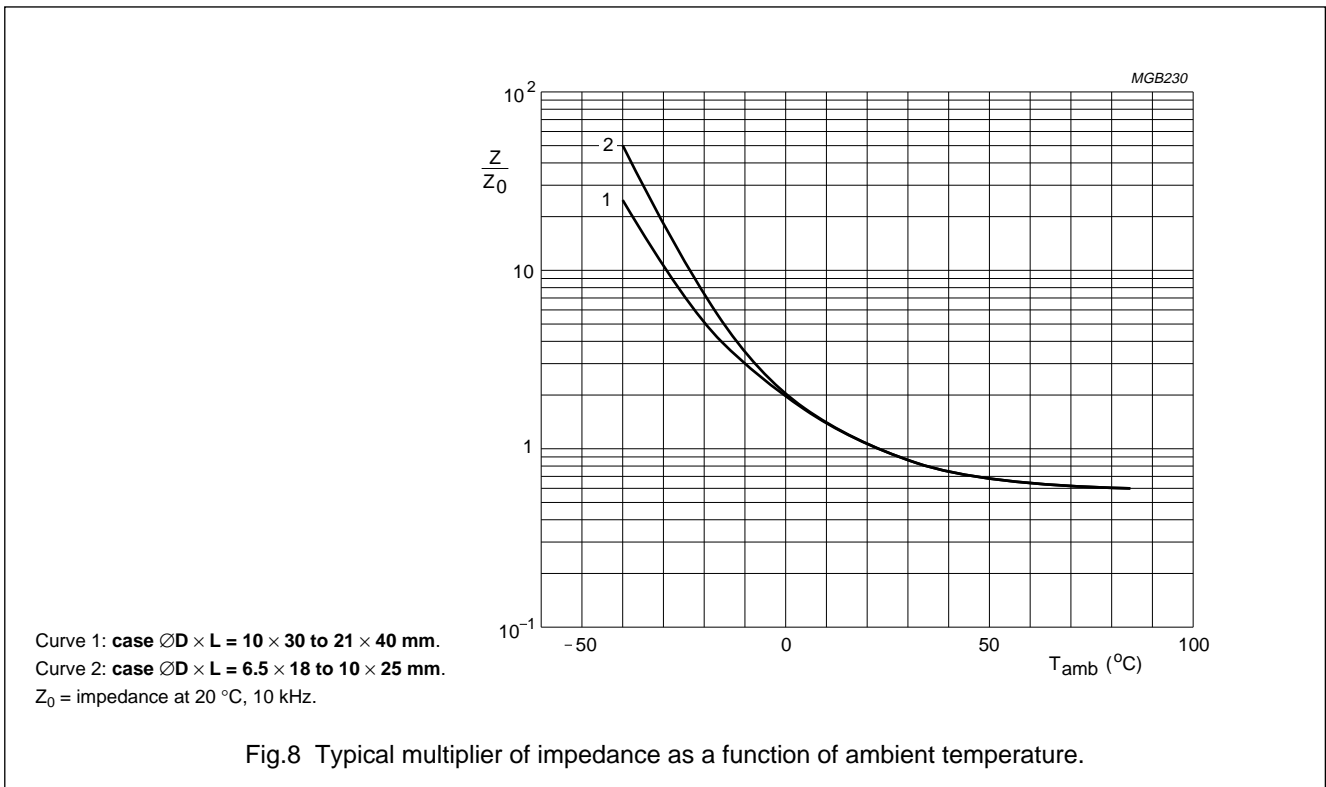

Non-solid Al - electrolytic capacitors
Axial Standard, High Voltage

ASH 041 - 043

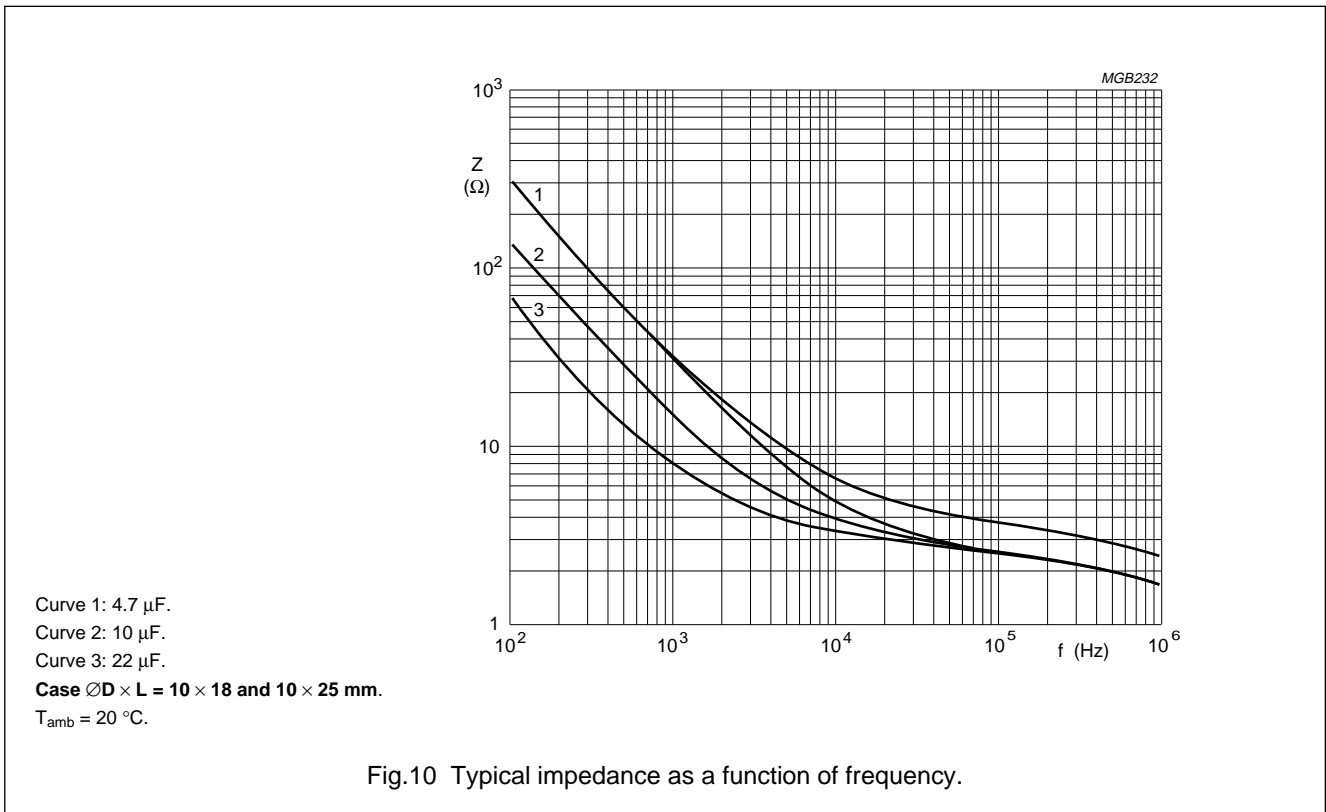
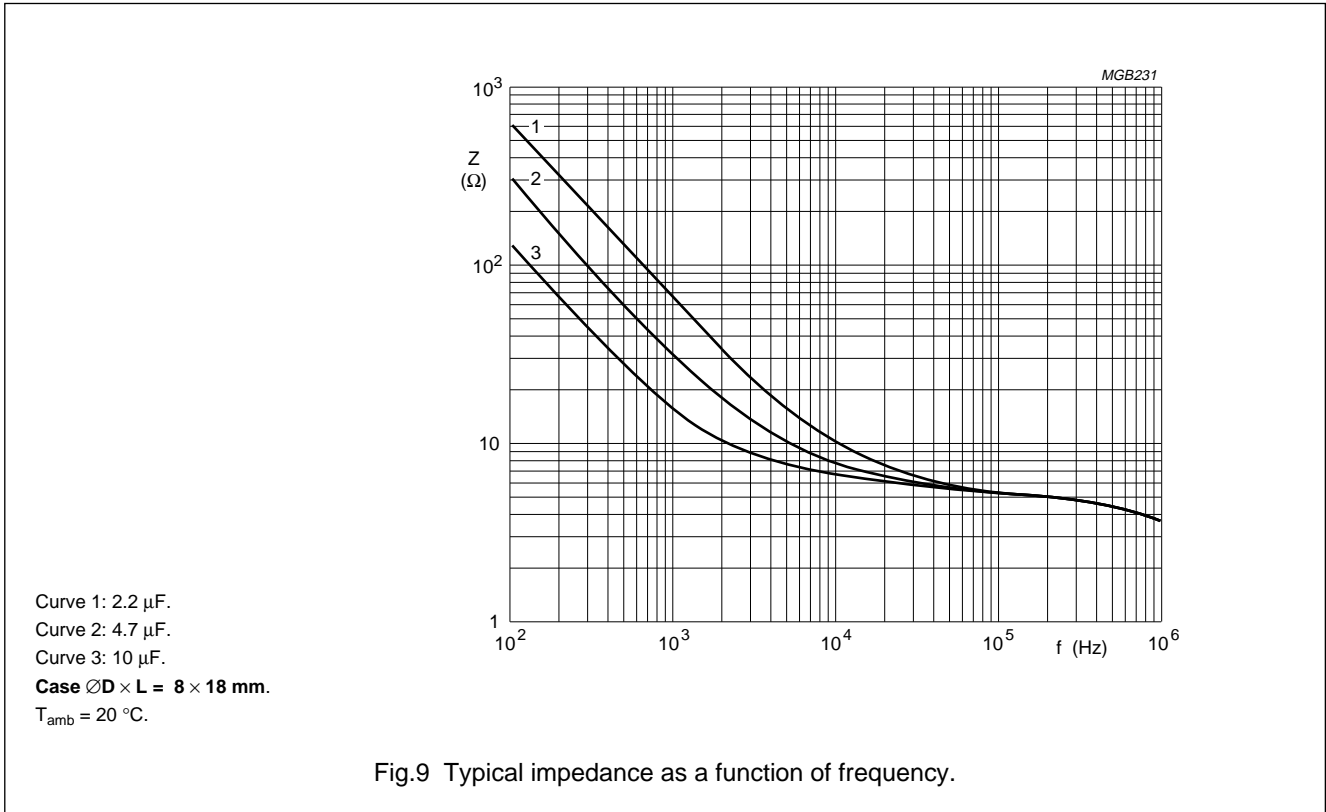

Non-solid Al - electrolytic capacitors
 Axial Standard, High Voltage

ASH 041 - 043

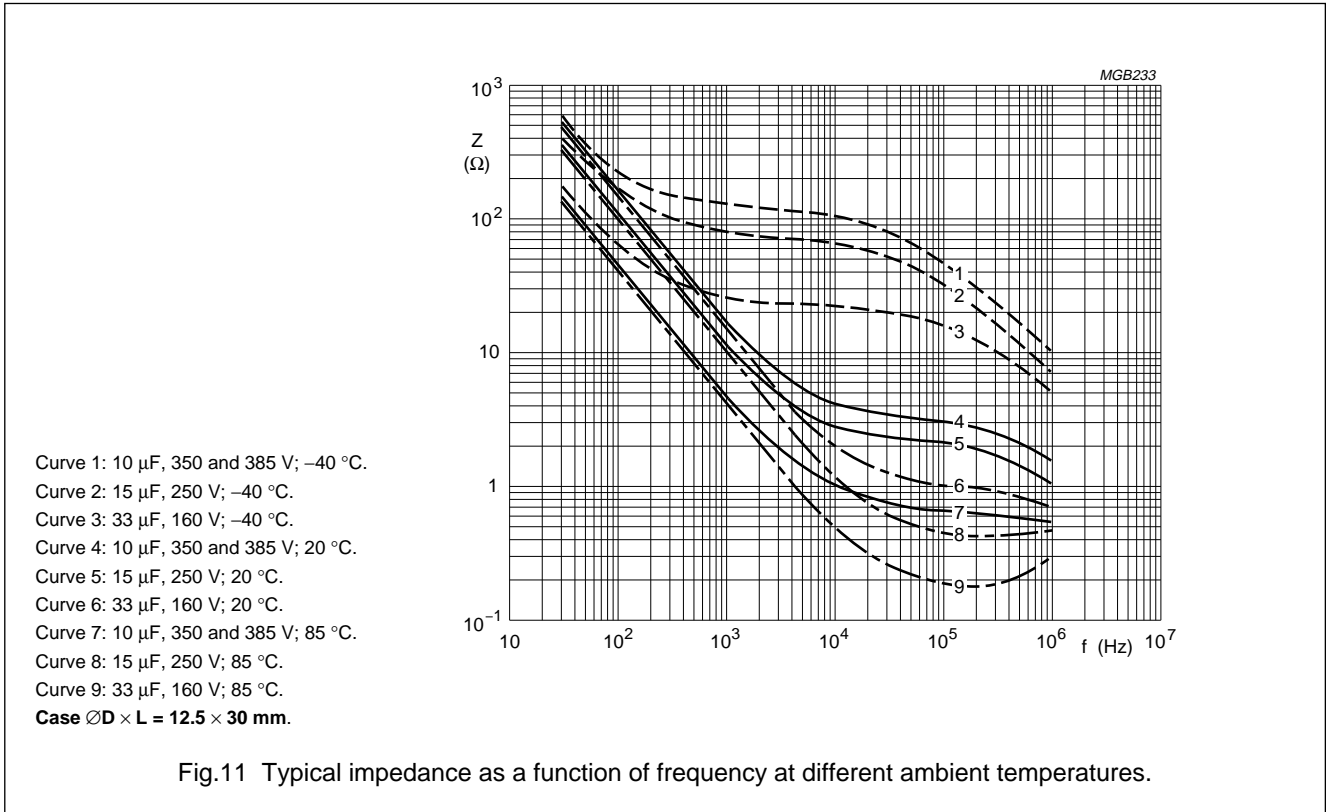

Non-solid Al - electrolytic capacitors
Axial Standard, High Voltage

ASH 041 - 043

RIPPLE CURRENT AND USEFUL LIFE

Table 4 Multiplier of ripple current (I_R/I_{R0}) as a function of frequency; I_{R0} = ripple current at 85 °C, 100 Hz

FREQUENCY (Hz)	I_R MULTIPLIER
50	0.75
100	1.0
300	1.15
1000	1.3
3000	1.4
≥10000	1.5

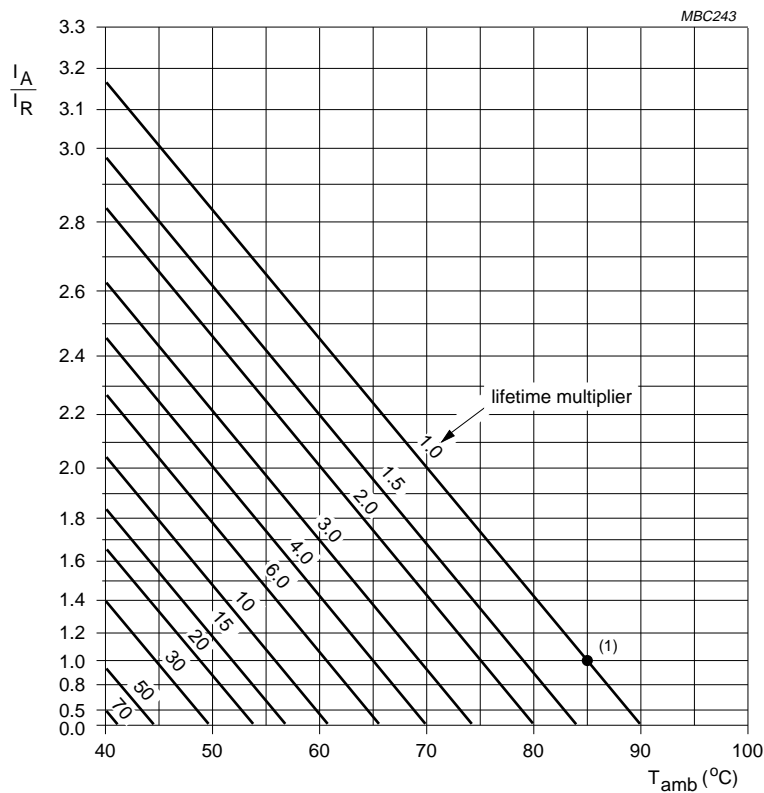

I_A = actual ripple current at 100 Hz.

I_R = rated ripple current at 100 Hz, 85 °C.

- (1) Useful life at 85 °C and I_R applied;
 case $\varnothing D \times L = 6.5 \times 18$ to 10×25 mm: 5000 hours
 case $\varnothing D \times L = 10 \times 30$ to 21×40 mm: 15000 hours (450 V: 5000 hours).

Fig.12 Multiplier of useful life as a function of ambient temperature and ripple current load.

Non-solid Al - electrolytic capacitors

Axial Standard, High Voltage

ASH 041 - 043

SPECIFIC TESTS AND REQUIREMENTS

General tests and requirements are specified in this handbook, section "Tests and Requirements".

Table 5 Test procedures and requirements

TEST		PROCEDURE (quick reference)	REQUIREMENTS
NAME OF TEST	REFERENCE		
Endurance	IEC 384-4/ CECC 30300 subclause 4.13	$T_{amb} = 85\text{ °C}$; U_R applied; case $\varnothing D \times L$: 6.5 × 18 to 10 × 25 mm: 2000 hours; 10 × 30 to 21 × 40 mm: 8000 hours (450 V: 2000 hours)	$U_R = 160\text{ V}$; $\Delta C/C$: $\pm 15\%$ $U_R = 250$ to 450 V; $\Delta C/C$: $\pm 10\%$ $\tan \delta \leq 1.3 \times \text{spec. limit}$ $Z \leq 2 \times \text{spec. limit}$ $I_{L5} \leq \text{spec. limit}$
Useful life	CECC 30301 subclause 1.8.1	$T_{amb} = 85\text{ °C}$; U_R and I_R applied; case $\varnothing D \times L$: 6.5 × 18 to 10 × 25 mm: 5000 hours; 10 × 30 to 21 × 40 mm: 15000 hours (450 V: 5000 hours)	$U_R = 160\text{ V}$; $\Delta C/C$: $\pm 45\%$ $U_R = 250$ to 450 V; $\Delta C/C$: $\pm 30\%$ $\tan \delta \leq 3 \times \text{spec. limit}$ $Z \leq 3 \times \text{spec. limit}$ $I_{L5} \leq \text{spec. limit}$ no short or open circuit total failure percentage: $\leq 3\%$
Shelf life (storage at high temperature)	IEC 384-4/ CECC 30300 subclause 4.17	$T_{amb} = 85\text{ °C}$; no voltage applied; 500 hours; after test: U_R to be applied for 30 minutes, 24 to 48 hours before measurement	$\Delta C/C$, $\tan \delta$, Z : for requirements, see 'Endurance test' above $I_{L5} \leq 2 \times \text{spec. limit}$