

LXW

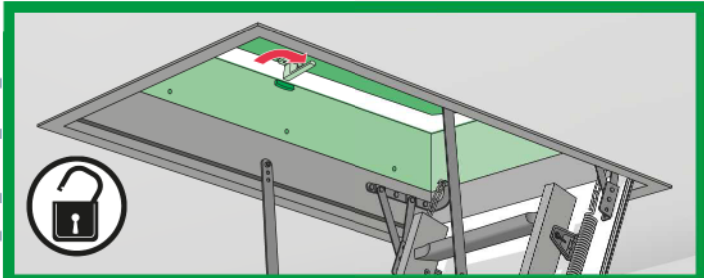

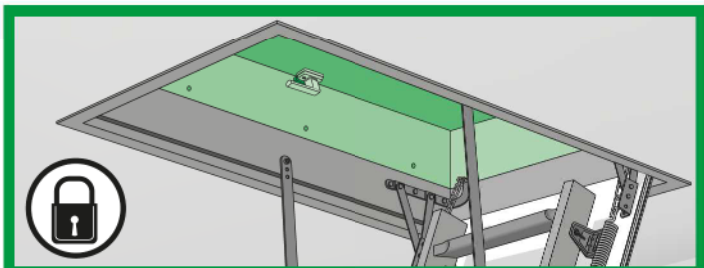
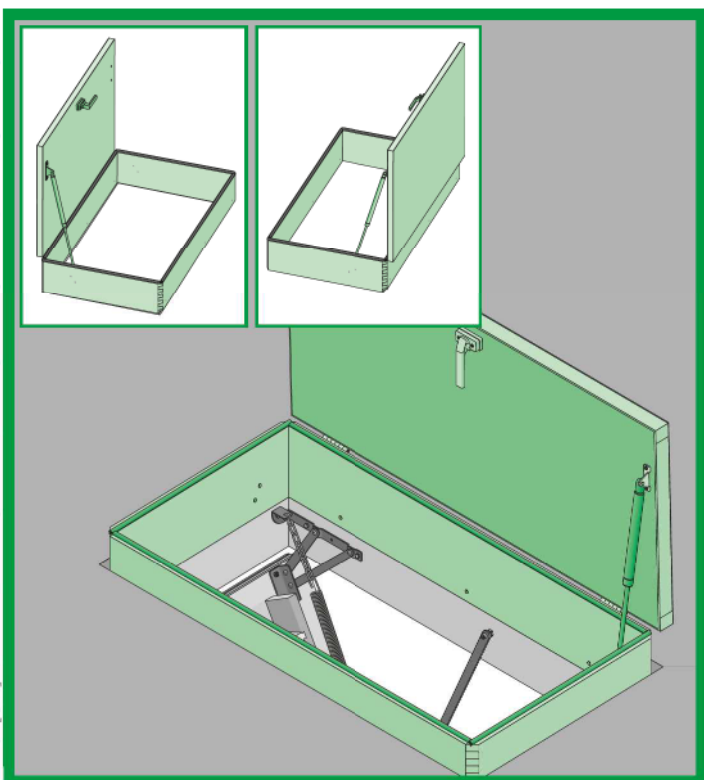
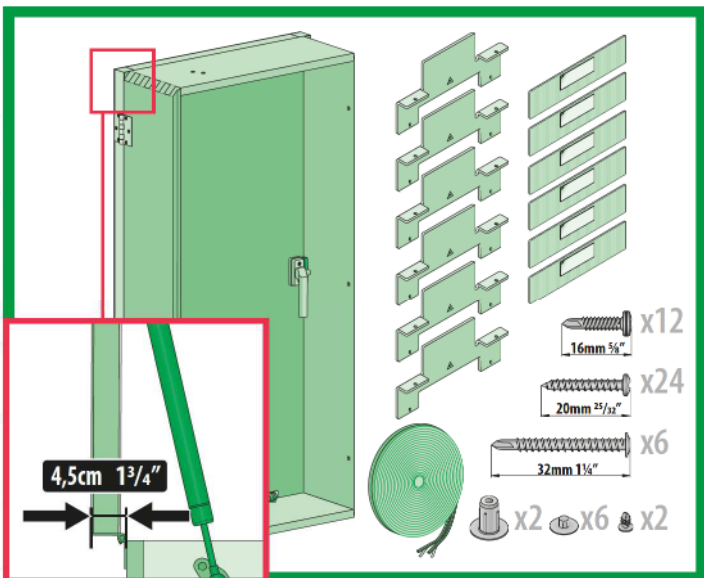

WARNING!

CZ	Montáž a používání výrobku je nutno provádět v souladu s návodem. Bezpečnost použití závisí na provedení všech činností uvedených v montážním návodu. POZOR! Montáž a používání výrobku v rozporu s návodem je zakázáno, může způsobit vážnou nehodu a má za následek ztrátu záruky a odpovědnosti výrobce.
DE	Die Montage und Verwendung des Produkts muss in Übereinstimmung mit Anleitung erfolgen. Die Bedienungssicherheit hängt davon ab, ob alle in der Montageanleitung genannten Tätigkeiten ausgeführt wurden. VORSICHT: Die Installation und der Gebrauch des Produkts, die nicht in der Übereinstimmung mit der Bedienungsanleitung erfolgt, kann einen schweren Unfall verursachen, schließt die Garantie aus und führt zu einem Mangel an Herstellerverantwortung.
EE	Toote paigaldus ja kasutamise peab olema vastavuses lisatud juhenditega. Kasutusohutus sõltub paigaldamisjuhistes näidatud kõigi toimingute rakendamisest. Tähelepanu! Juhistele mitte vastav kasutamine on rangelt keelatud kuna võib põhjustada tõsise õnnetuse, see tühistab garantiid ning muudab Tootja toote eest enam mitte vastutavaks.
ES	El montaje y uso del producto deben realizarse de acuerdo con las instrucciones. La seguridad de uso de la escalera depende de la correcta realización de todas las acciones indicadas en el manual de instalación. ¡ATENCIÓN! Está prohibida la instalación y uso del producto diferente a lo indicado en las instrucciones, ya que puede provocar un accidente grave, anula la garantía y causa la pérdida de responsabilidad del fabricante.
FI	Tuotteiden asennus ja käyttö on suoritettava asennusohjeiden ja käyttöohjeiden mukaisesti. Tuotteiden turvallinen käyttö edellyttää, että asennusohjeissa näytetyt toimenpiteet on tehty. Varoitus! Jos tuotteita käytetään ohjeiden vastaisesti, saattaa se aiheuttaa vakavan onnettomuuden.
FR	L'installation et l'utilisation doivent être effectuées conformément aux instructions de montage et aux instructions d'utilisation. La sécurité d'utilisation dépend de la réalisation de toutes les activités indiquées dans l'instruction de montage. ATTENTION! L'installation et l'utilisation du produit contraire aux instructions est interdite, cela peut provoquer un accident grave, supprime la garantie et entraîne le dégageement de la responsabilité du fabricant.
GB	Installation and use of the product should be strictly in accordance with included instructions. Safety of use depends on the implementation of all actions shown in the fitting instructions. CAUTION! Installation and use of the product in violation of the instructions is strictly forbidden as it may cause a serious injury, it invalidates the warranty and makes the manufacturer no longer liable for the product.
HU	A terméket az útmutatóban lévő utasítások alapján kell beépíteni és üzemeltetni. Az üzemeltetés biztonságára függ a beépítési útmutatóban feltüntetett valamennyi művelet elvégzésétől. FIGYELEM! A termék útmutatóval ellentétes beépítése, használata és üzemeltetése tilos, mindez súlyos balesethez vezethet, garanciavesztéssel jár, továbbá kizárja a gyártó felelősségét.
IT	L'installazione e l'uso va fatto nel pieno rispetto delle istruzioni. La sicurezza d'uso dipende dalla realizzazione di tutte le attività indicate nelle istruzioni di montaggio. Attenzione! è assolutamente vietato l'utilizzo difforme alle istruzioni d'uso dato che può essere causa di gravi incidenti ed in ogni caso fa decadere la garanzia nonché qualsiasi responsabilità del produttore.
LT	Montuojant ir naudojantis gaminiu, būtina laikytis gamintojo instrukcijų. Naudojimo saugumas priklauso nuo visų veiksmų, nurodytų montavimo instrukcijoje. Dėmesio! Neteisingas gaminio montavimas ir naudojimas, pažeidžiant instrukcijas, griežtai draudžiamas, nes tai gali sukelti rimtą nelaimingą atsitikimą, ir gamintojas turi teisę panaikinti garantiją ir nebeatsakyti už gaminį.
LV	Produkta uzstādīšana un lietošana veicama atbilstoši ražotāja instrukcijām. Droša lietošana ir atkarīga no tā, vai precīzi ievērotas visas uzstādīšanas instrukcijas. Uzmanību! Produkta lietošana pretrunā ar instrukcijas prasībām var izraisīt nopietnus nelaimes gadījumus, kā arī instrukciju neievērošana pārtrauc noteikto garantijas apkalpošanu un ražotāja atbildību par produktu.
NL	Het is noodzakelijk dat dit product strikt volgens de bijgeleverde instructies wordt geïnstalleerd en gebruikt. De gebruiksveiligheid is afhankelijk van de uitvoering van alle handelingen uit de montagehandleiding. BELANGRIJK! Installatie en gebruik van het product, dat niet voldoet aan de instructies, is niet toegestaan. Het kan ernstig letsel veroorzaken en zorgt ervoor dat de garantie vervalt. De fabrikant is in deze gevallen niet meer aansprakelijk voor het product.
PL	Montaż i użytkowanie produktu należy wykonywać zgodnie z instrukcją. Bezpieczeństwo użytkowania zależy od wykonania wszystkich czynności wskazanych w instrukcji montażu. UWAGA! Montaż i użytkowanie produktu niezgodnie z instrukcją jest zabronione, może spowodować groźny wypadek, wyłącza gwarancję oraz powoduje brak odpowiedzialności producenta.
PT	A montagem e o uso do produto devem ser realizados de acordo com as instruções. A segurança na utilização depende da execução de todas as ações indicadas nas instruções de montagem. ATENÇÃO! A instalação e utilização do produto, contrária às instruções, é proibida, podem causar são proibidos, podem causar acidentes graves, anulam a garantia e desresponsabilizam o fabricante.
RO	Asamblarea și utilizarea produsului trebuie efectuate în conformitate cu instrucțiunile. Siguranța utilizării depinde de punerea în practică a tuturor acțiunilor prezentate în instrucțiunile de montaj. NOTĂ! Instalarea și utilizarea produsului contrare instrucțiunilor este interzisă, poate provoca un accident grav, dezactivează garanția și cauzează răspunderea producătorului.
RU	Монтаж и эксплуатацию продукта необходимо проводить согласно правилам соответствующих инструкций. Безопасность эксплуатации зависит от выполнения всех правил, представленных в инструкции по монтажу. ВНИМАНИЕ! Нарушение или игнорирование правил может быть причиной несчастного случая, отменяет гарантию производителя, а также его ответственность.
SI	Montaža in uporaba izdelka morata ustrezati navodilom. Varnost uporabe je odvisna od izvedbe vseh postopkov naštetih v navodilih za montažo. POZOR: v primeru, da vgradnja in uporaba izdelka nista v skladu s montažnimi in uporabnimi navodili, lahko povzročita težko nesrečo. V tem primeru je proizvajalčeva odgovornost izključena zato je garancija izdelka neveljavna.
SK	Montáž a používanie výrobku je potrebné vykonávať v súlade s návodom. Bezpečnosť použitia závisí na prevedení všetkých činností uvedených v montážnom. Pozor! Používanie výrobku v rozpore s návodom je zakázané, môže spôsobiť vážnu nehodu a má za následok stratu záruky a zodpovednosti výrobcu.
US	Installation and use of the product should be strictly in accordance with included instructions. Safety of use depends on the implementation of all actions shown in the fitting instructions. CAUTION! Installation and use of the product in violation of the instructions is strictly forbidden as it may cause a serious injury, it invalidates the warranty and makes the manufacturer no longer liable for the product.



PZ2

10mm

$\varnothing 2,5 \text{ mm } \frac{3}{32}'' \times 1$

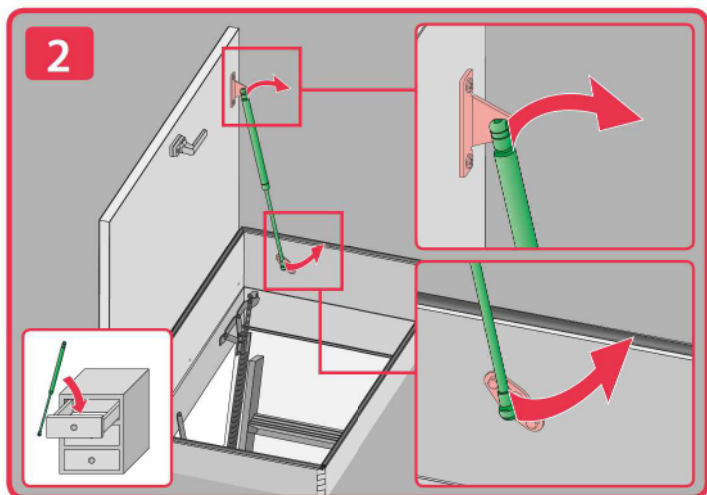
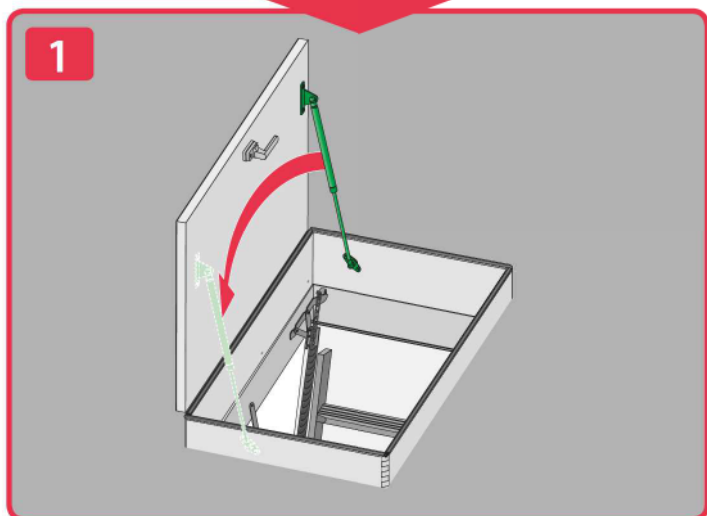
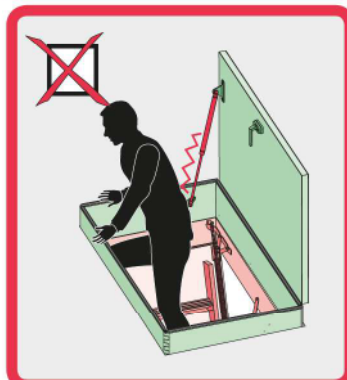

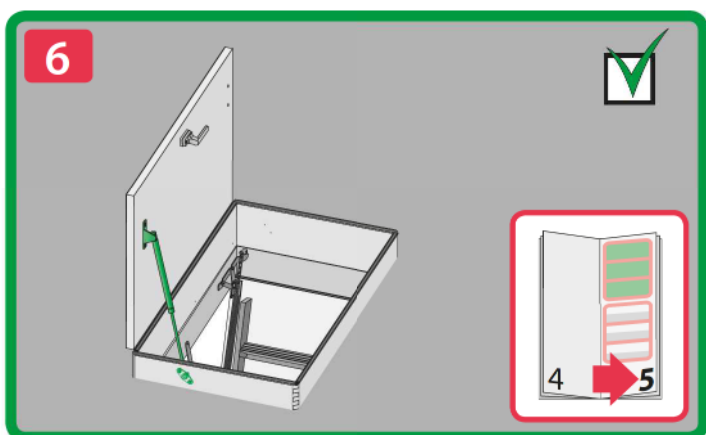
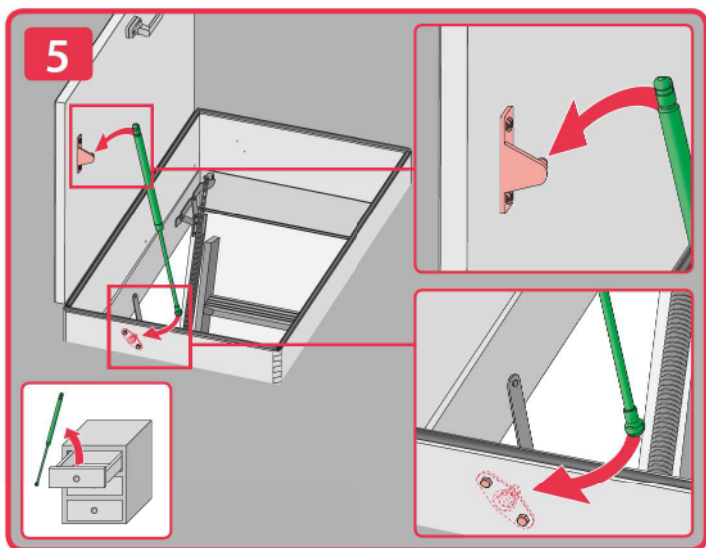
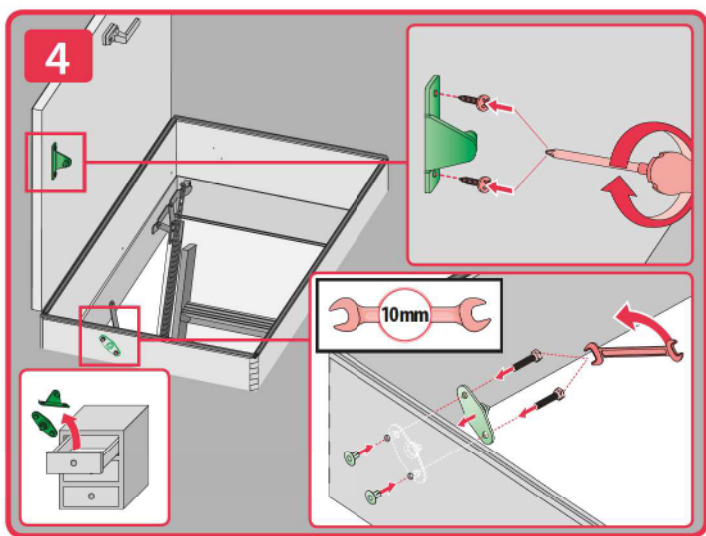
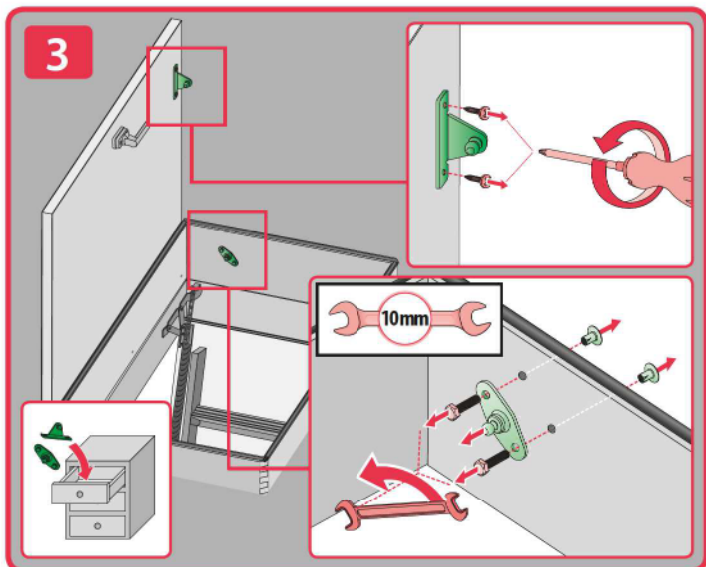

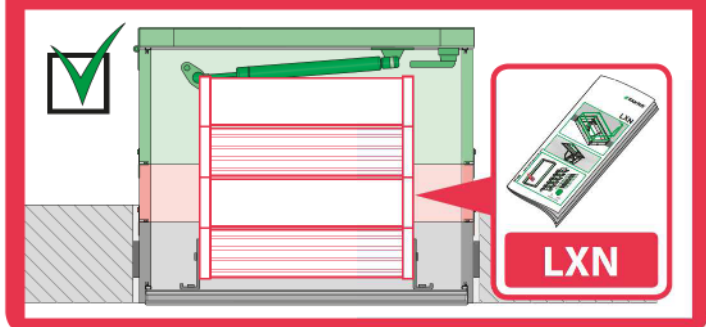
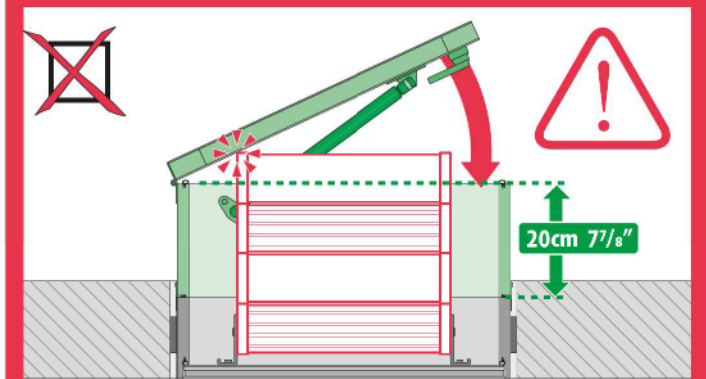
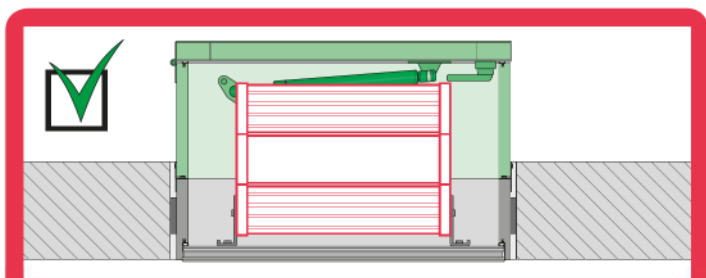
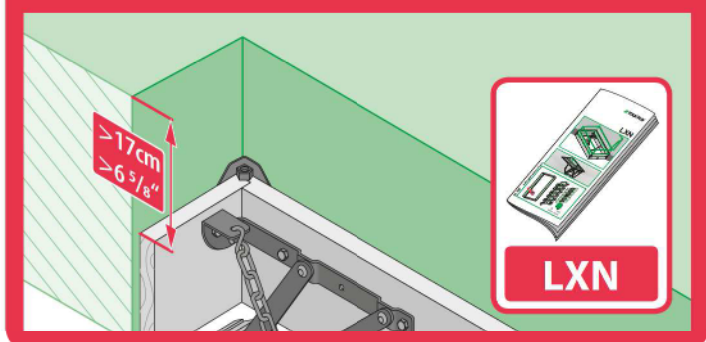
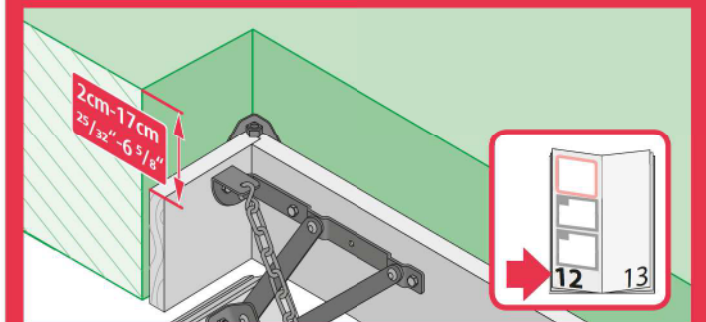
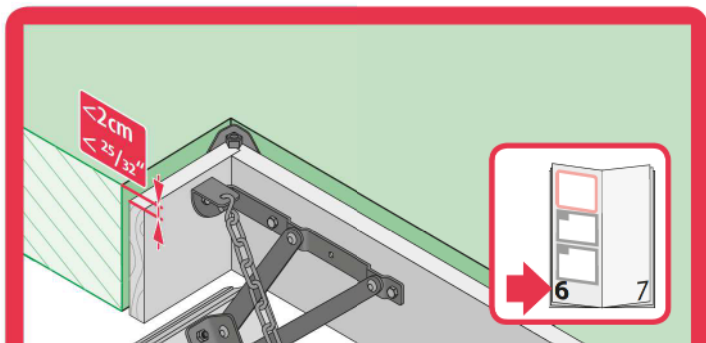

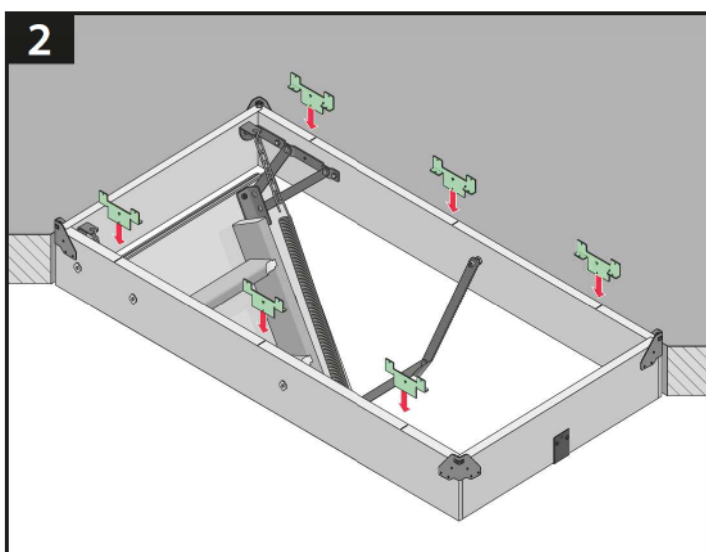
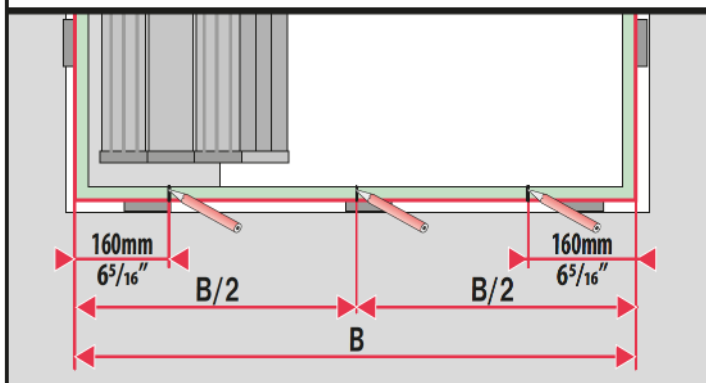
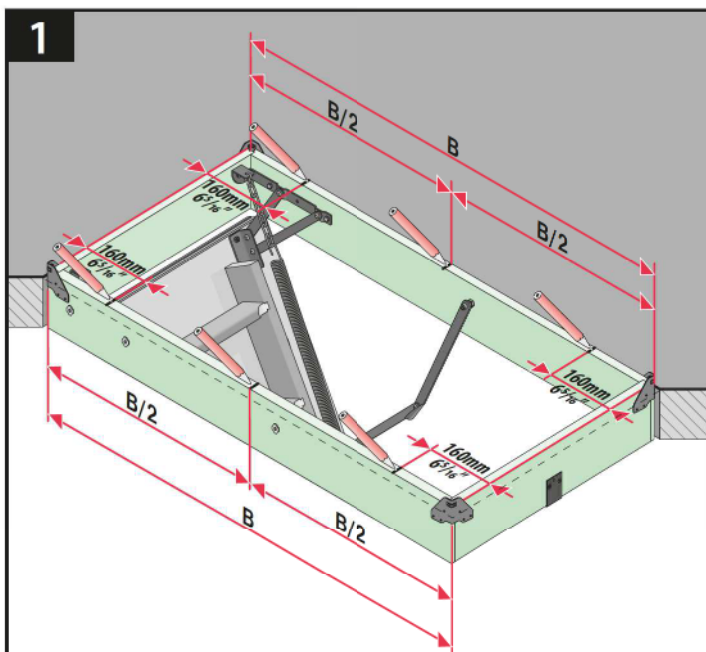
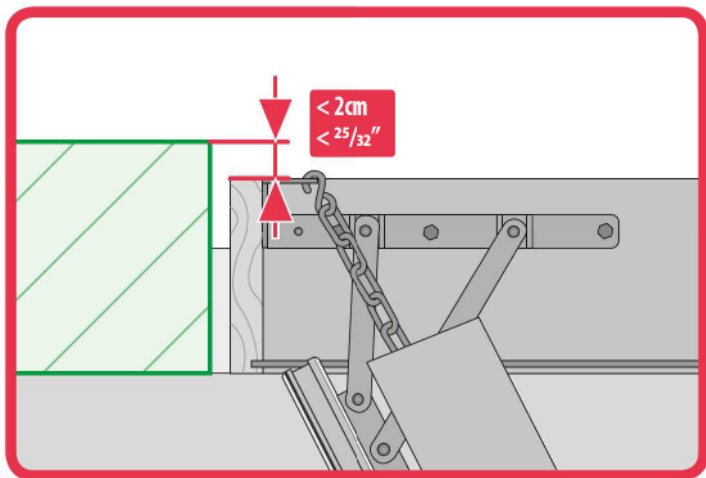

2a

Ø2,5mm 3/32"

20mm 25/32"

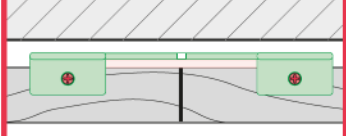
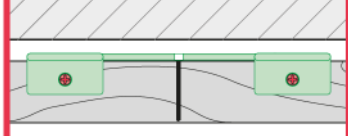
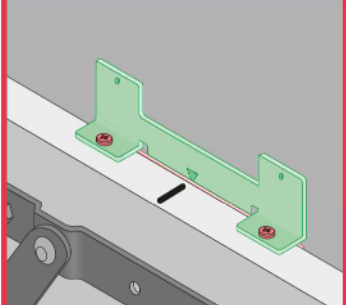
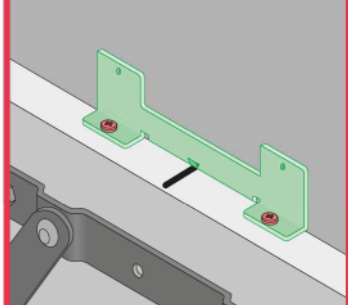
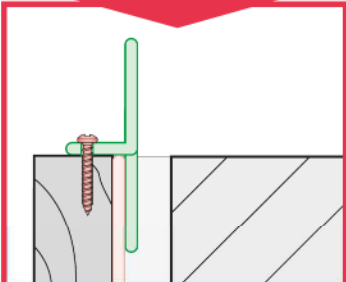
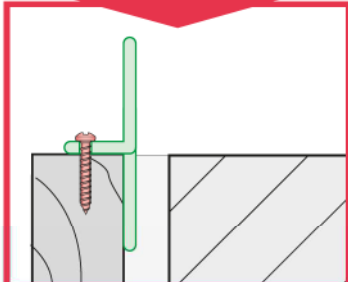
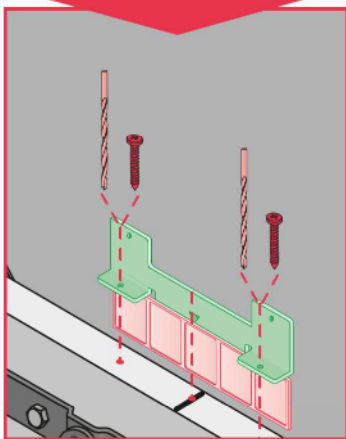
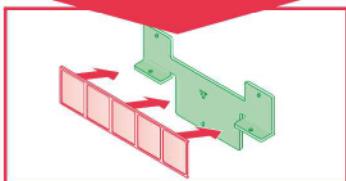
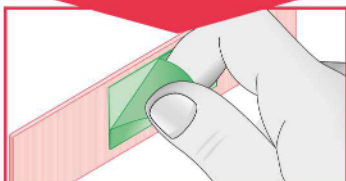
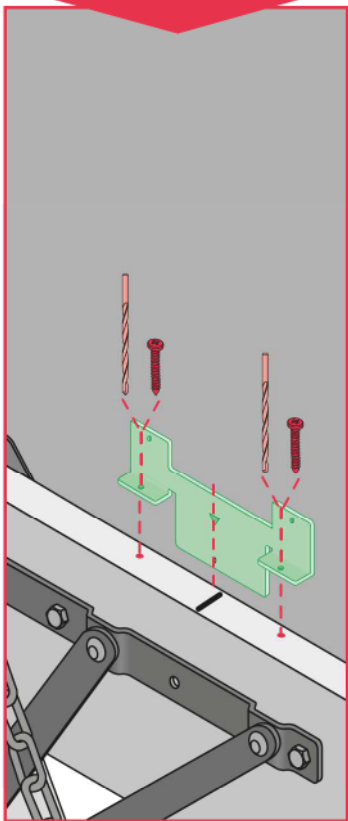
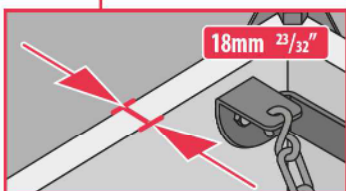
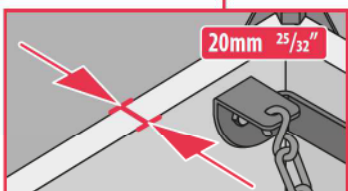
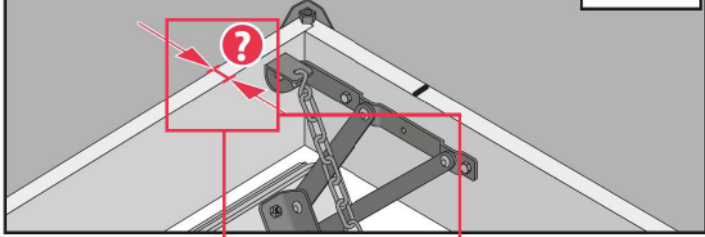

2b

LMF

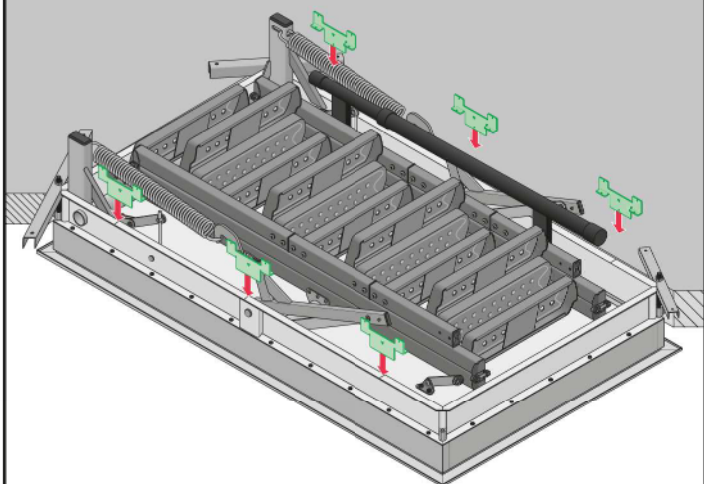

Ø2,5mm 3/32"

16mm 5/8"

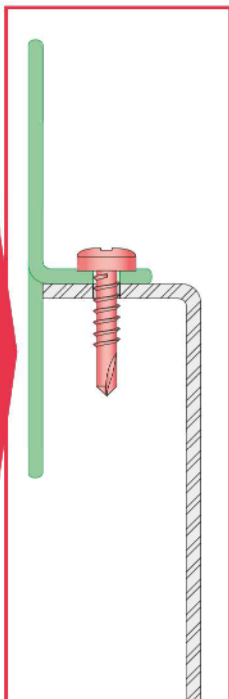
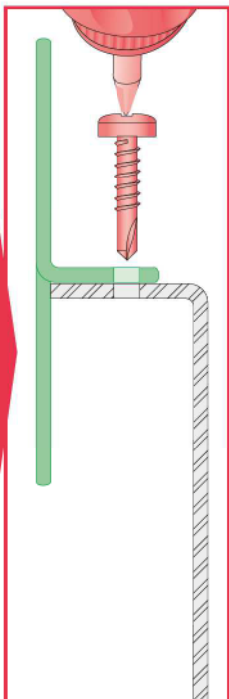
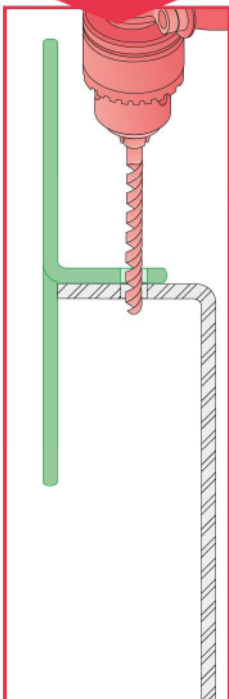
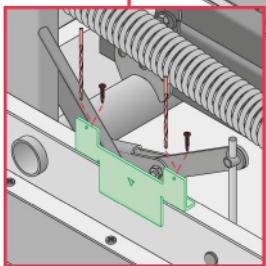
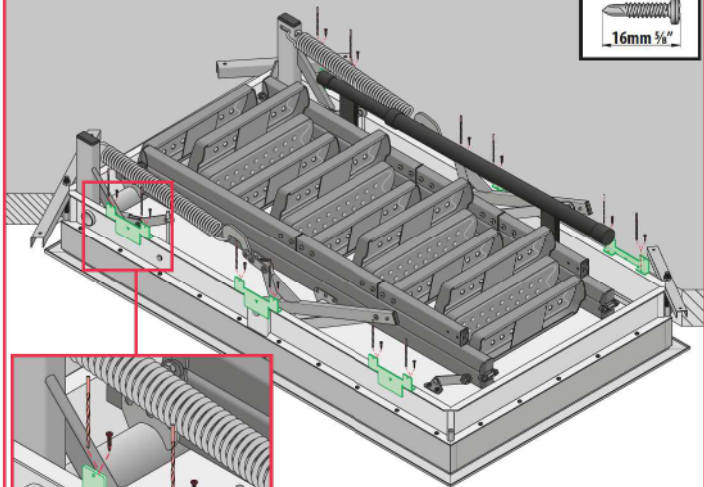

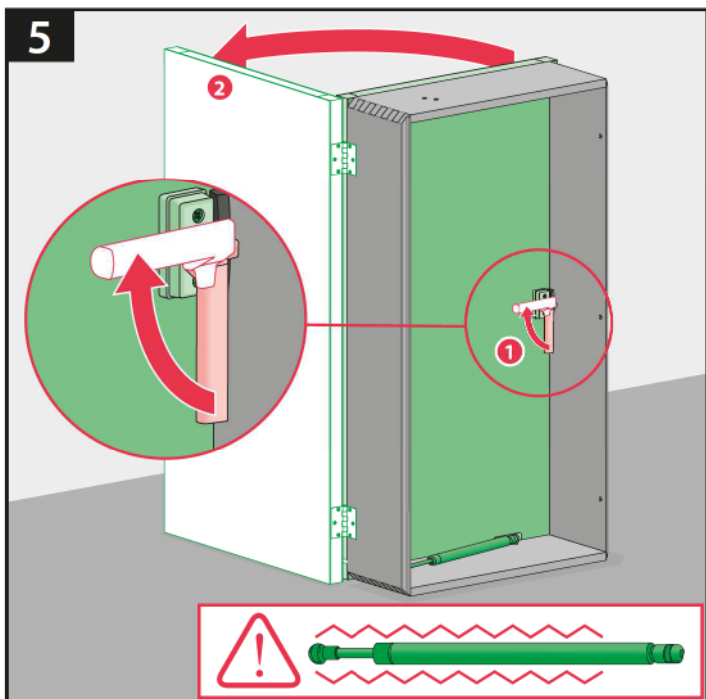
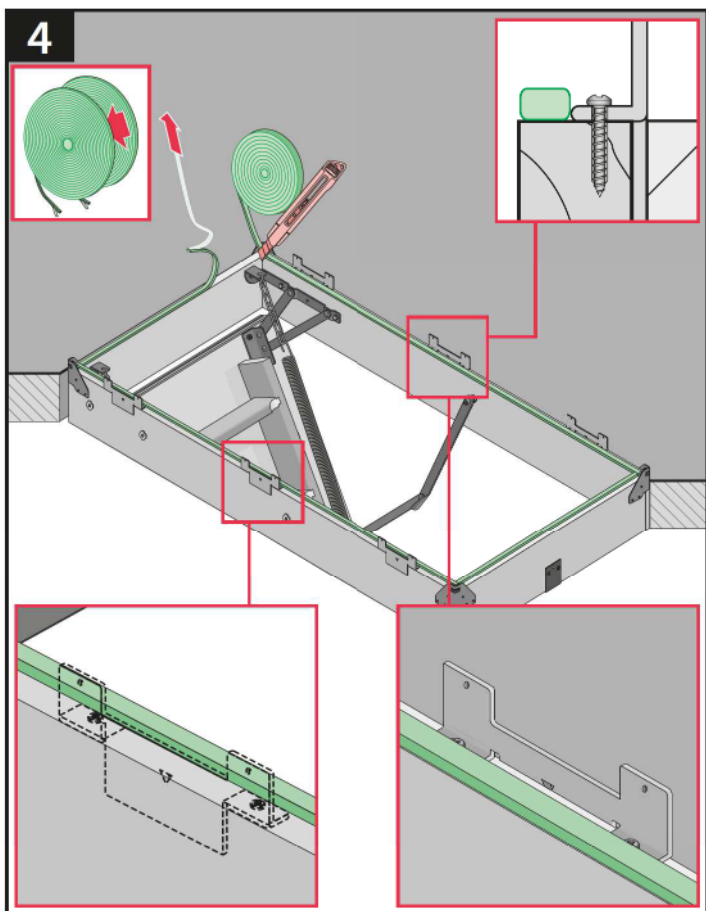
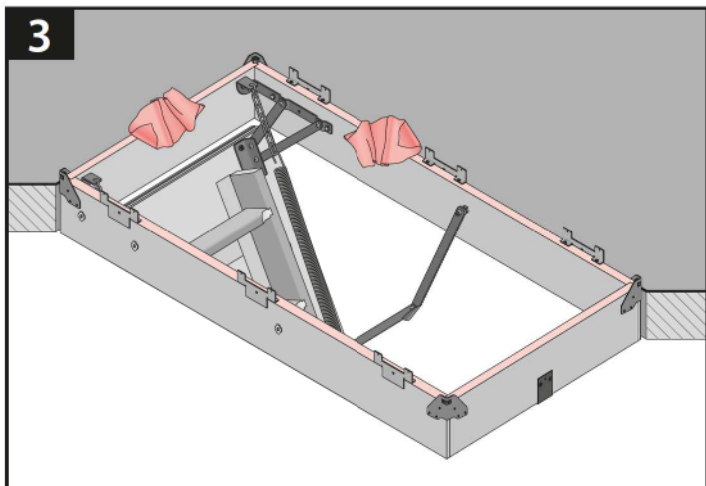

6

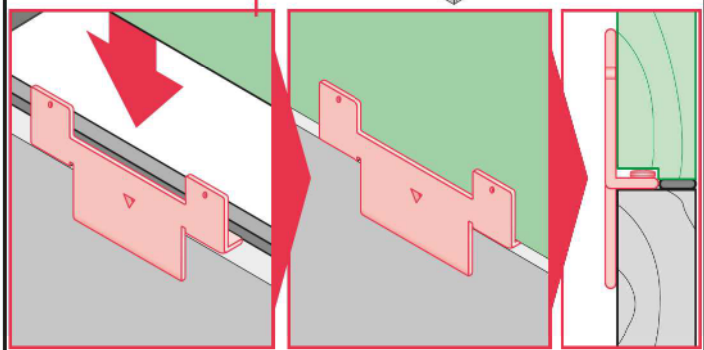
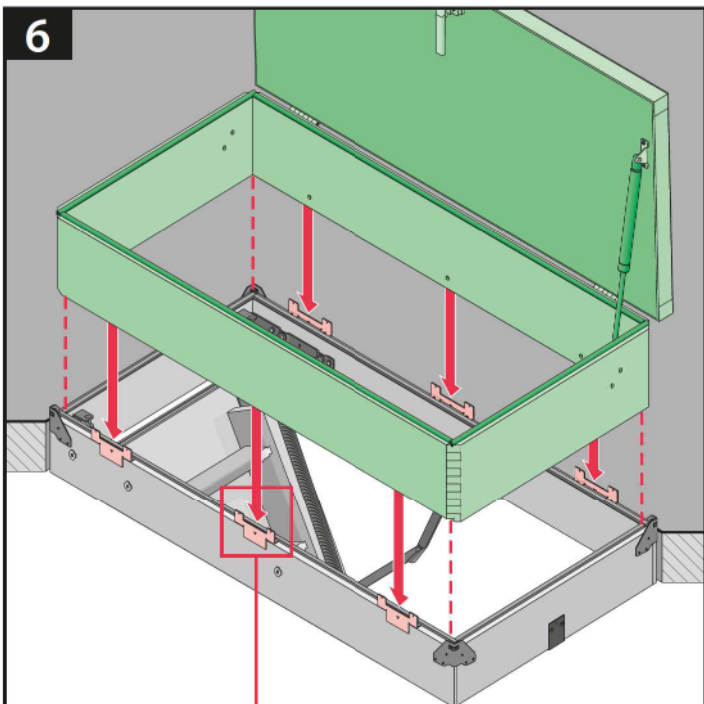

7

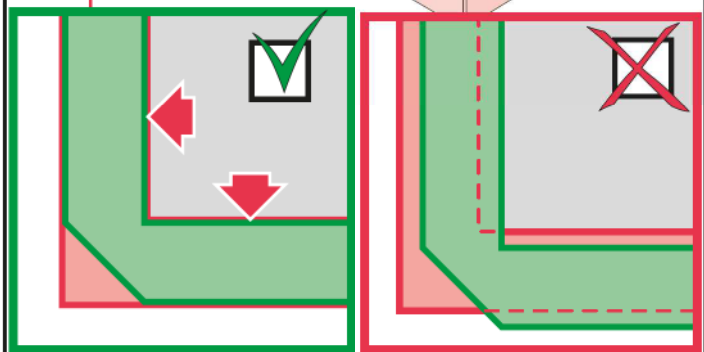
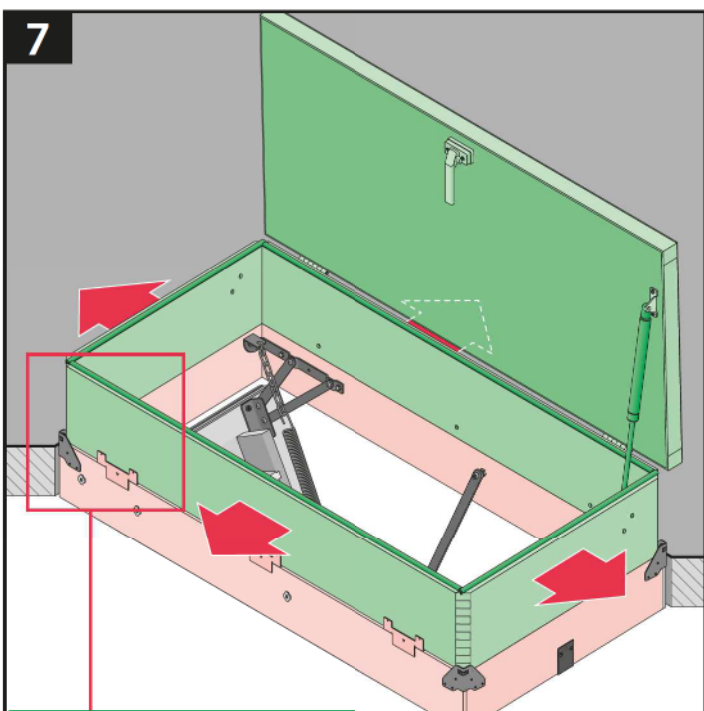

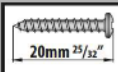
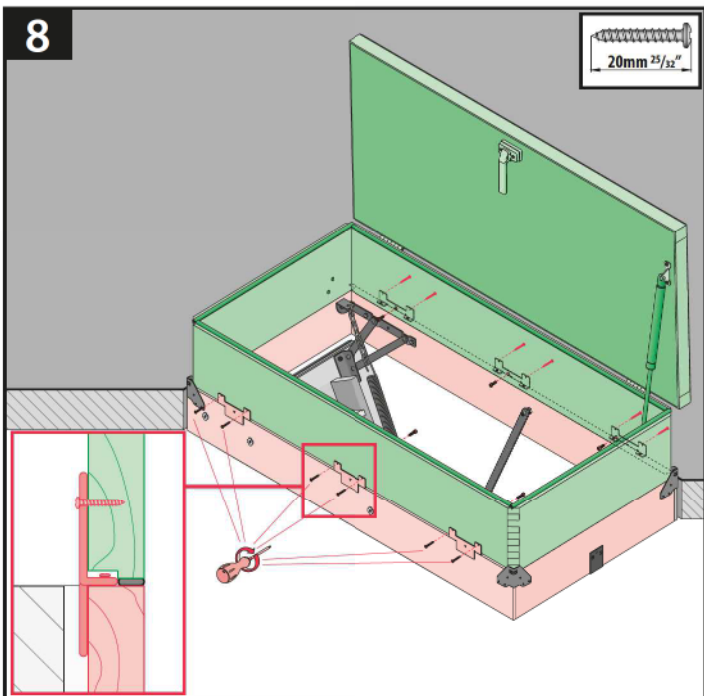
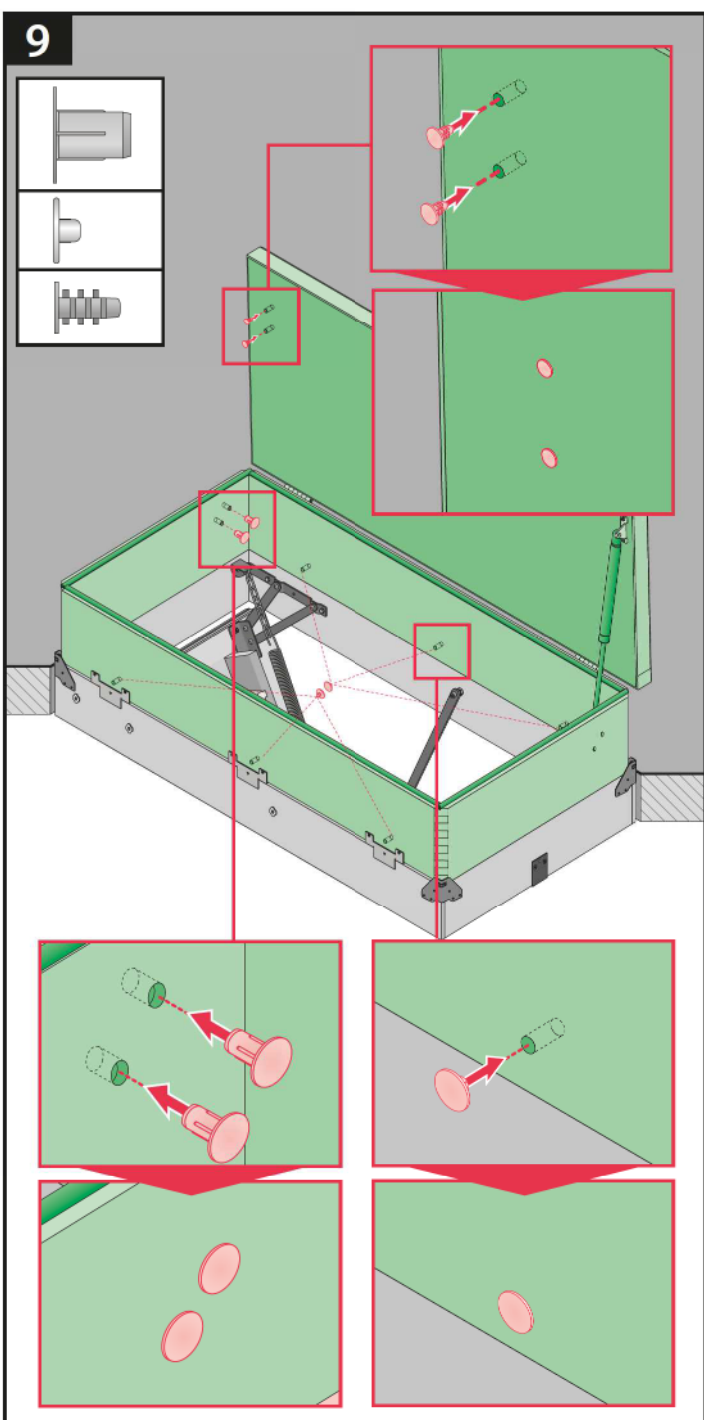
8

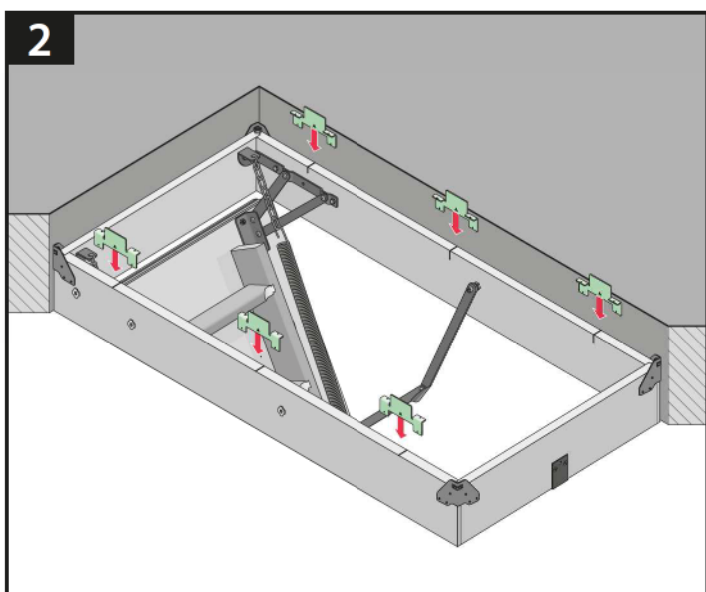
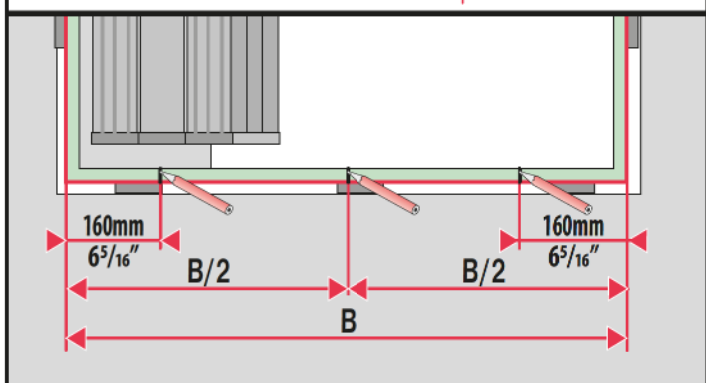
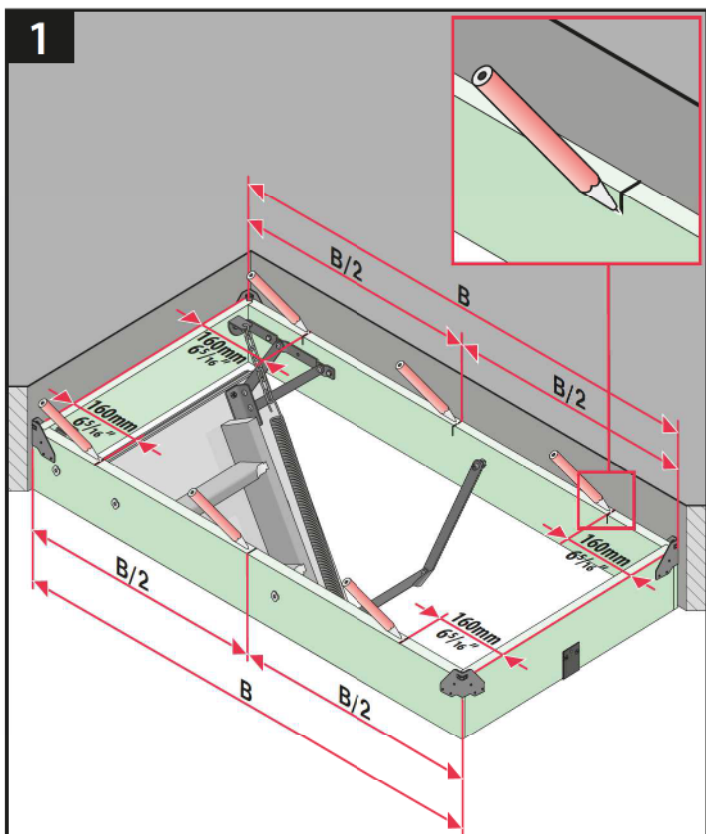
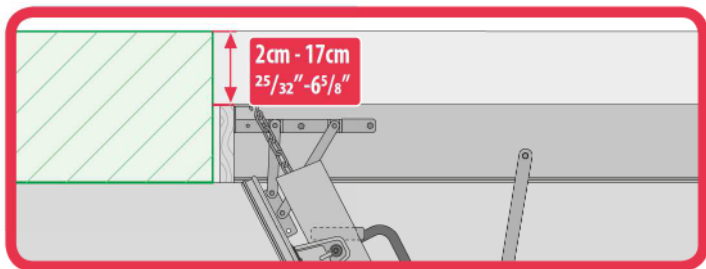
 20mm $\frac{25}{32}$ "
**9**



2a

Ø2,5mm 3/32"

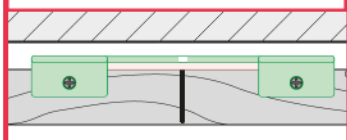
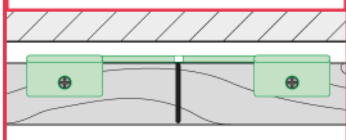
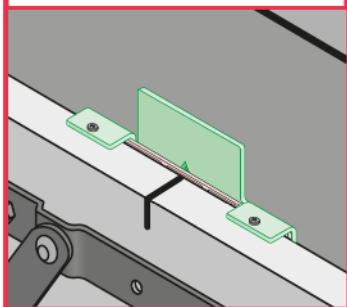
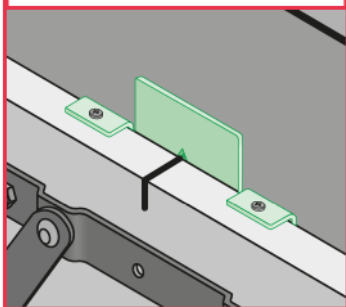
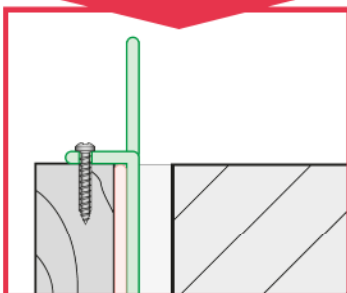
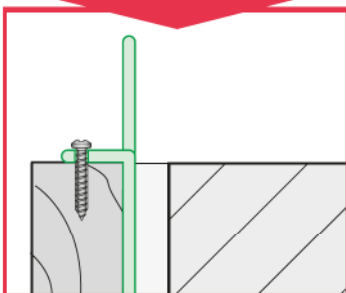
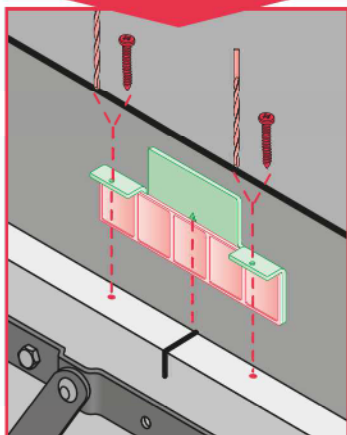
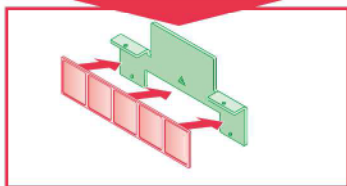
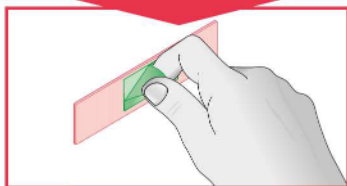
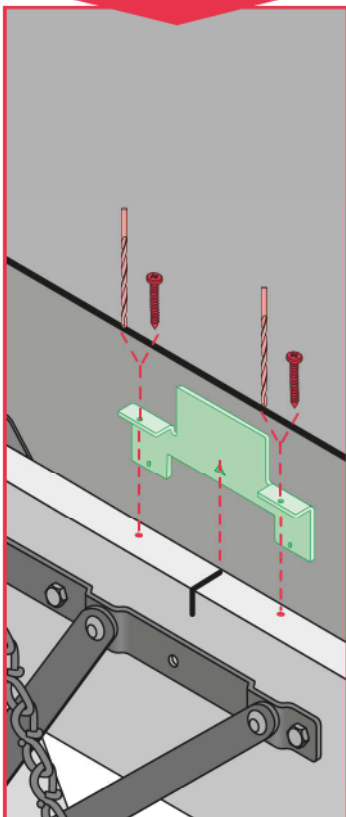
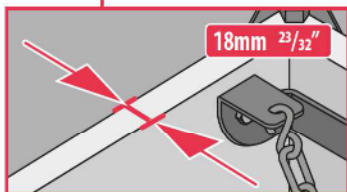
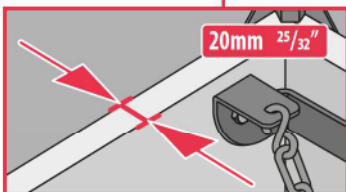
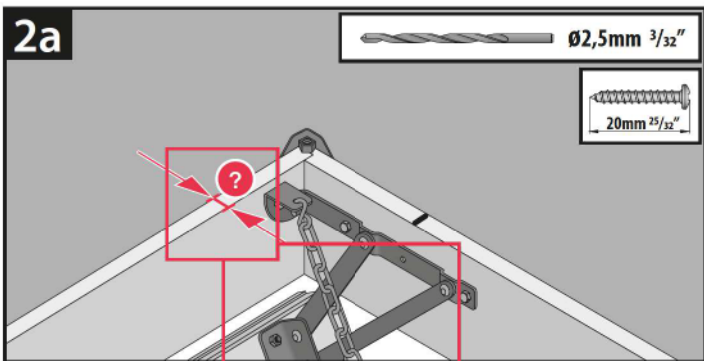
20mm 25/32"



2b

LMF

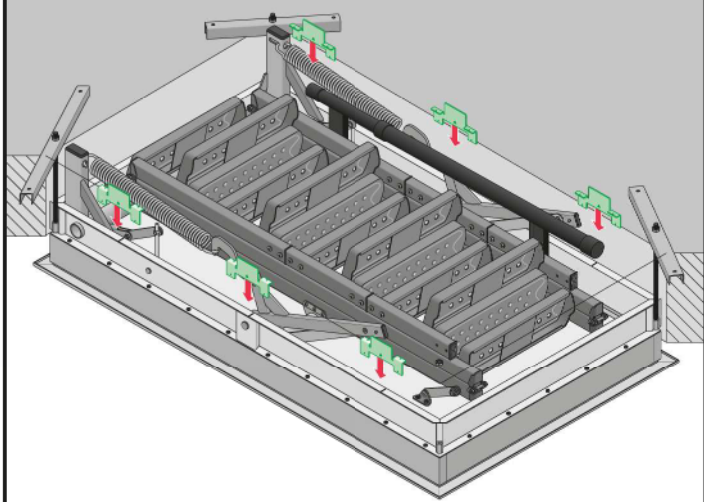

Ø2,5mm 3/32"

16mm 5/8"

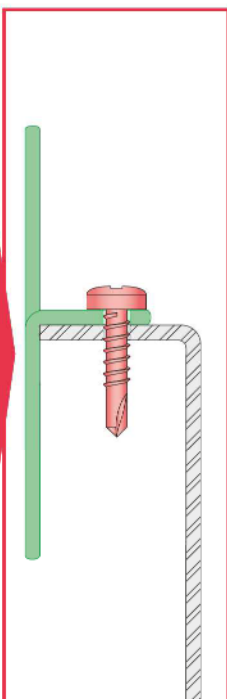
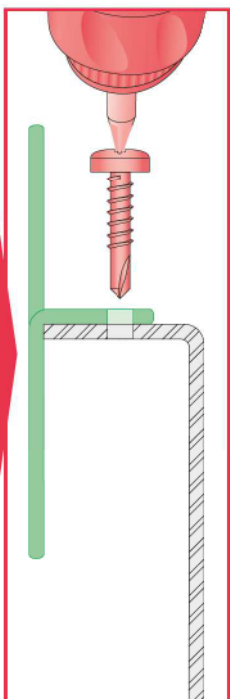
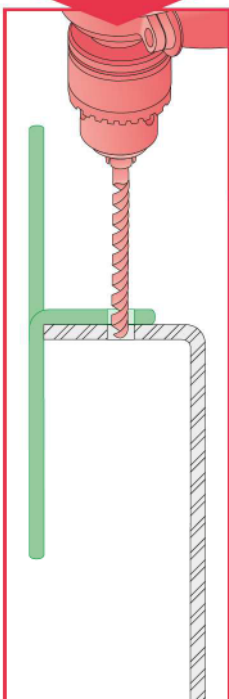
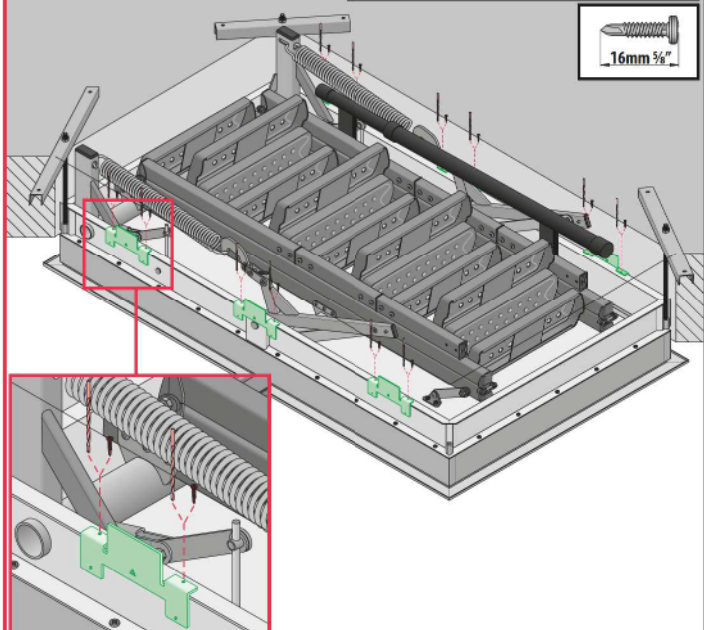

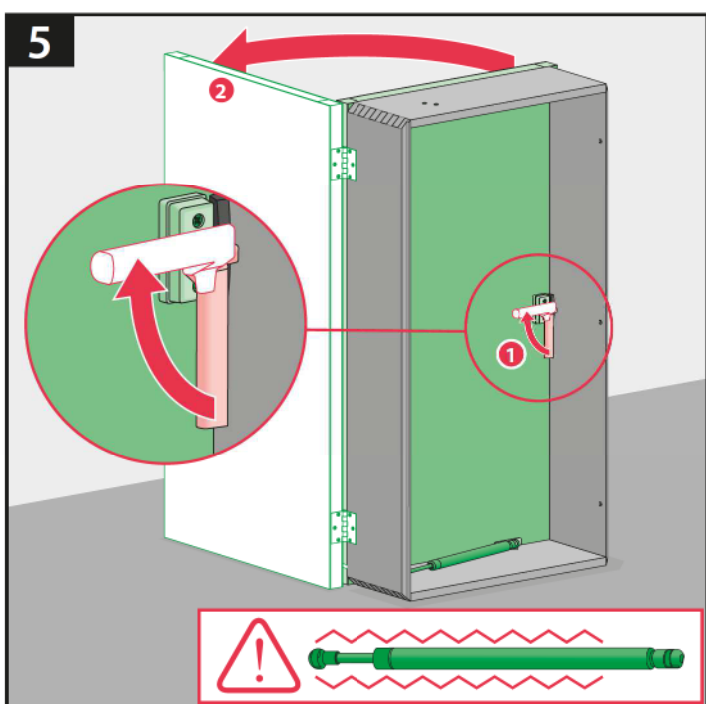
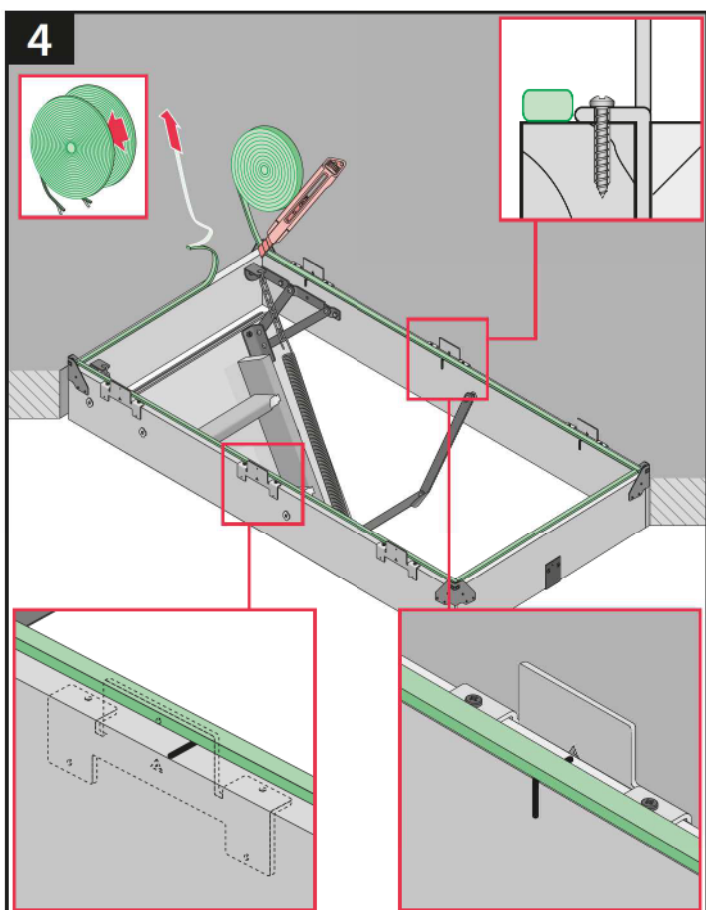
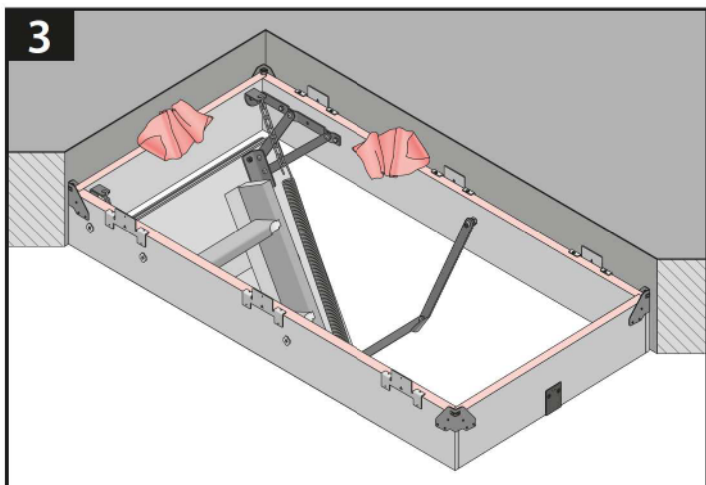

6

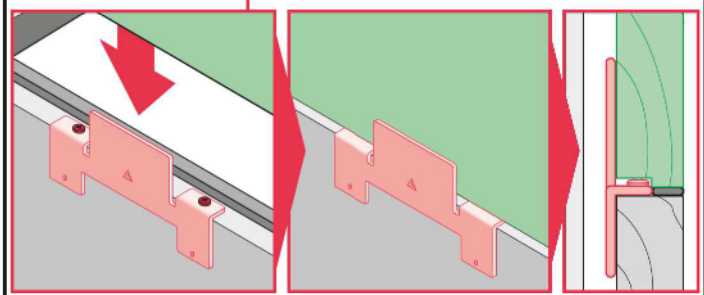
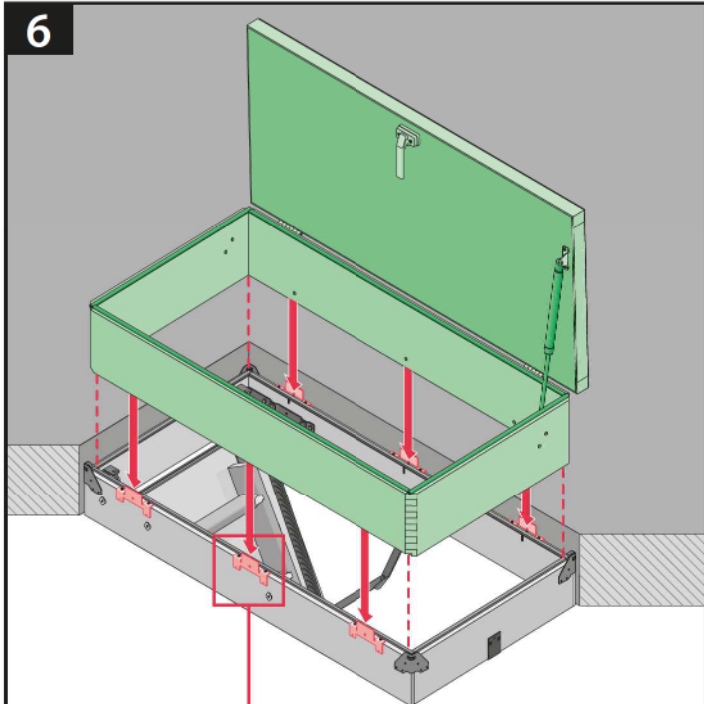

7

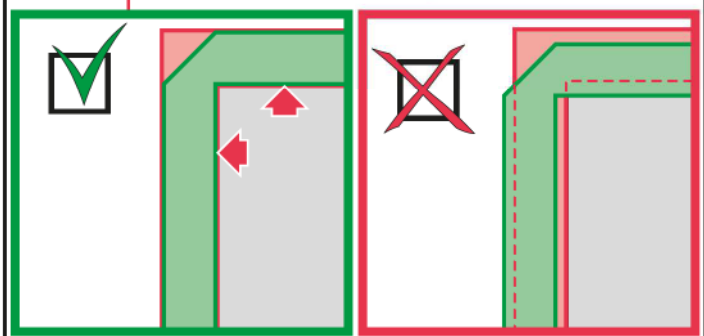
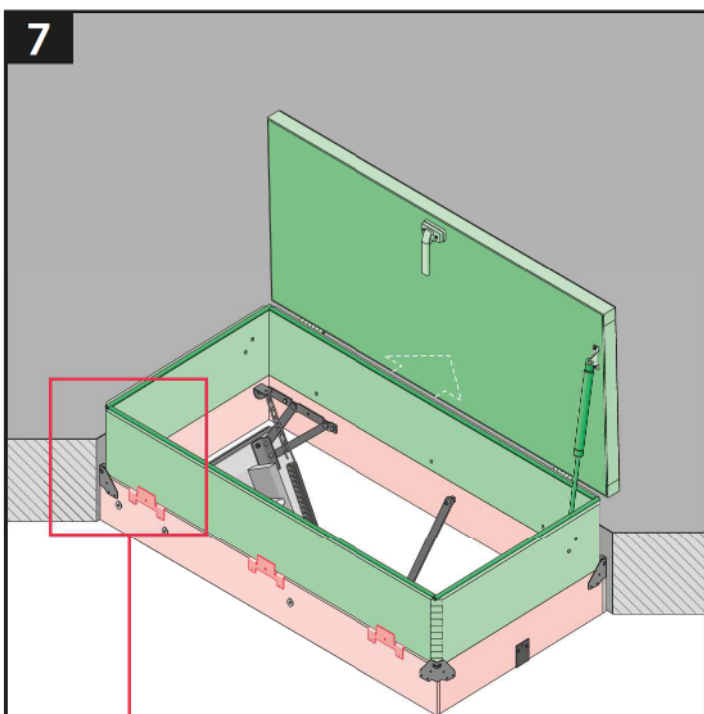

8

Ø2,5mm 3/32"

32mm 1 1/4"

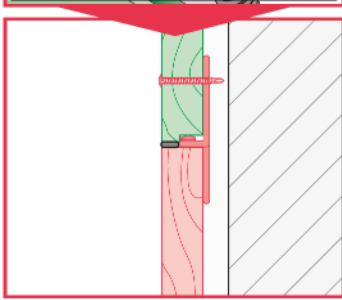
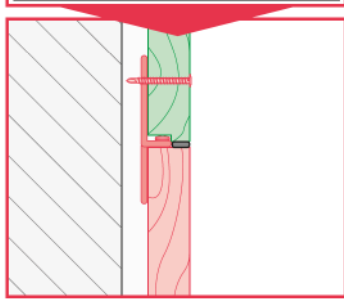
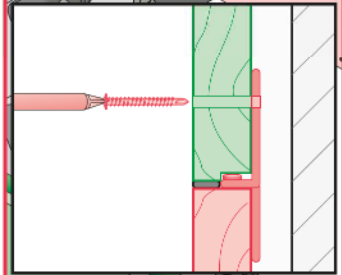
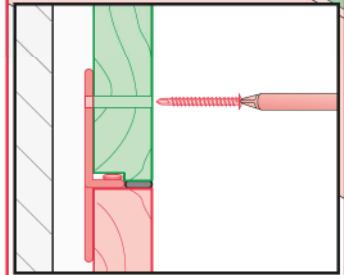
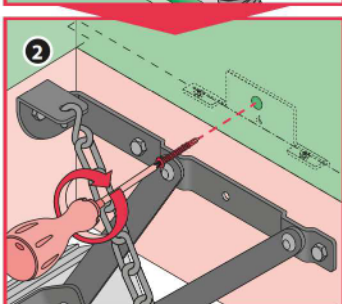
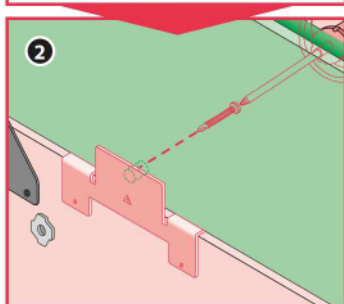
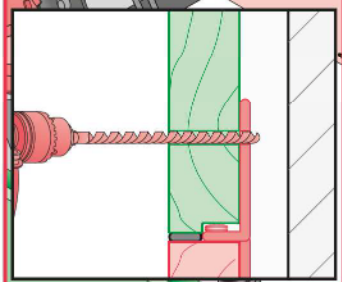
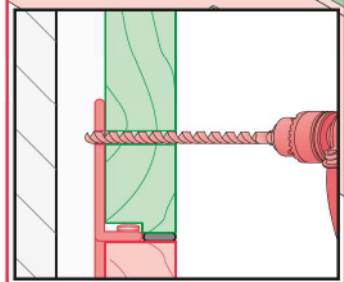
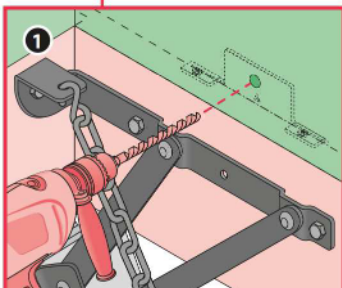
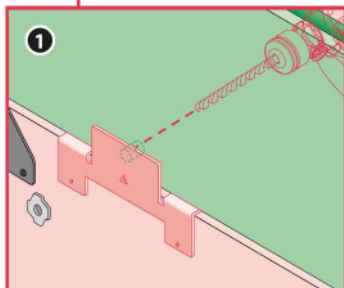
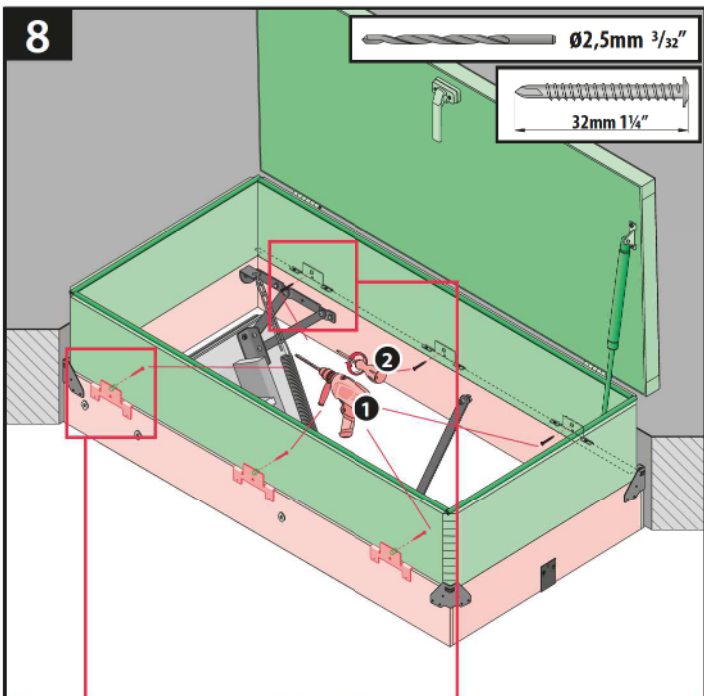

9

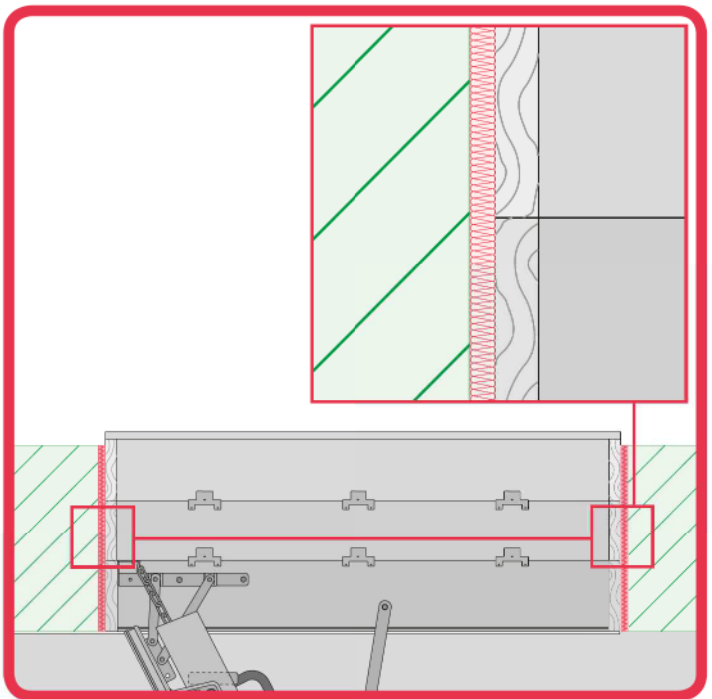
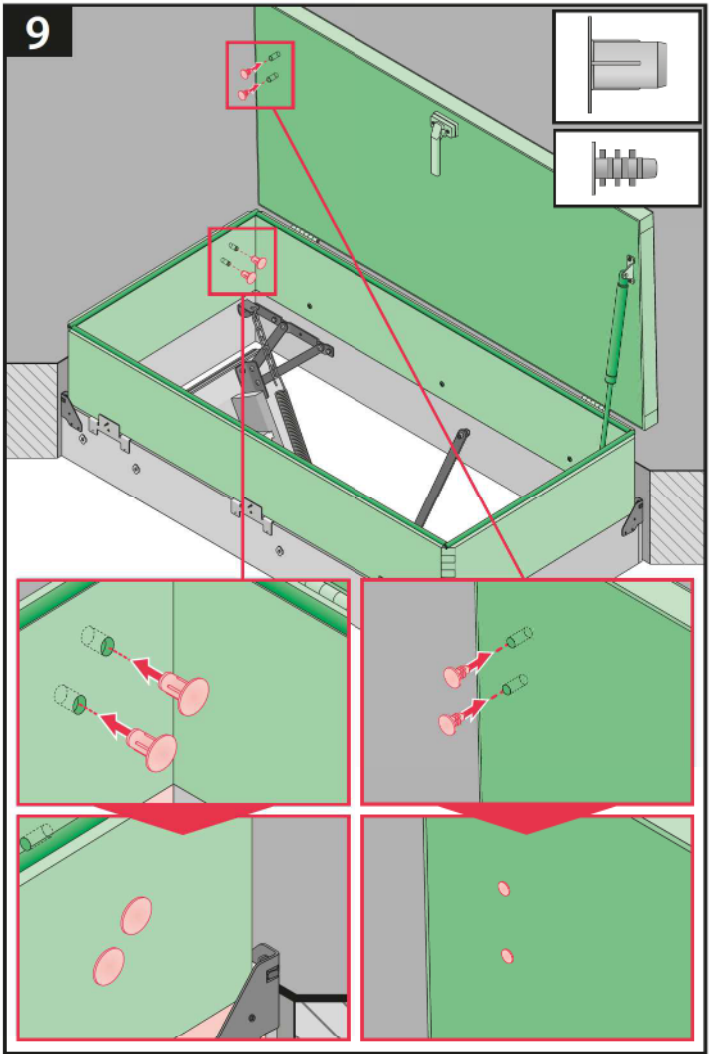

0 [cm] 1 2 3 4 5 6 7 8 9 10 11 12 13 14 15 16 17 18 19 20

BG	Производител и Продавач не носят отговорност за неспазване на съответните закони, строителни норми и изисквания за безопасност от потребителя на продукта, архитекта, монтажника или собственика на сградата.	IT	Il Produttore e il Rivenditore non potranno essere ritenuti responsabili per il mancato rispetto, da parte dell'utente del prodotto, del progettista, dell'installatore o del proprietario dell'edificio, delle leggi vigenti, nonché dei regolamenti edilizi e di quelli relativi alla sicurezza.
CZ	Výrobce ani prodejce nenesou žádnou odpovědnost za nedodržení příslušných platných zákonů, stavebních předpisů a bezpečnostních požadavků uživatelem výrobku, architektem, montážníkem nebo vlastníkem budovy.	NL	De fabrikant en verkoper zijn niet aansprakelijk voor gevolgen bij het niet opvolgen van toepasselijke wetten, bouwbesluiten en veiligheidsvoorschriften door de gebruiker van het product, de architect, de installateur of de eigenaar van het gebouw.
DE	Hersteller und Verkäufer übernehmen keine Haftung für Nichtbeachtung entsprechender Rechts- und Bauvorschriften sowie Sicherheitsanforderungen seitens Produktbenutzers, Architekten, Monteurs oder Gebäudebesitzers.	PL	Producent i Sprzedawca nie ponoszą żadnej odpowiedzialności za nieprzebranie stosownych przepisów prawa, przepisów budowlanych i wymogów bezpieczeństwa przez użytkownika produktu, architekta, montażystę lub właściciela budynku.
ES	El fabricante y el vendedor no tienen ninguna responsabilidad por el incumplimiento de la ley vigente, normas de construcción y exigencias de seguridad por parte del usuario del producto, arquitecto, instalador o el propietario del edificio.	PT	O fabricante e o vendedor não tem nenhuma responsabilidade pelo não cumprimento da lei, códigos de construção e as exigências de segurança por parte do usuário do produto, arquiteto, instalador ou proprietário do edifício.
FR	Le fabricant et le revendeur ne prend aucune responsabilité de ne pas respecter les lois applicables, les règlements sur les bâtiments et les exigences de sécurité par l'utilisateur du produit, l'architecte, l'installateur ou le propriétaire du bâtiment.	RO	Nici producătorul, nici distribuitorul nu își vor asuma niciun fel de răspundere pentru nerespectarea legilor în vigoare, a legilor din domeniul construcțiilor sau a măsurilor de siguranță impuse utilizatorilor produsului, arhitecților, montajorilor sau proprietarilor clădirii.
GB	Manufacturer and Seller shall bear no liability for failure to comply with the applicable laws, building codes and safety requirements by the user of the product, architect, fitter or owner of the building.	RU	В случае несоблюдения архитектором, монтажником или владельцем здания строительных правил и норм безопасности ответственность с производителя и продавца снимается.
HU	A Gyártó és a Forgalmazó nem vállal semmilyen felelősséget a vonatkozó törvényi, építési és biztonsági előírások temétfelhasználó, építész, beépítőmester vagy épületlajdosos által be nem tartásáért.	SK	Výrobca a predajca nenesú žiadnu zodpovednosť za nedodržanie príslušných ustanovení zákona, stavebných predpisov a bezpečnostných požiadaviek užívateľom výrobku, architektom, montérom alebo majiteľom objektu.