

VEVOR

Affordable. Reliable. Home Improvement.





KIDS STORAGE CUBES

MODEL:ZD-25A01

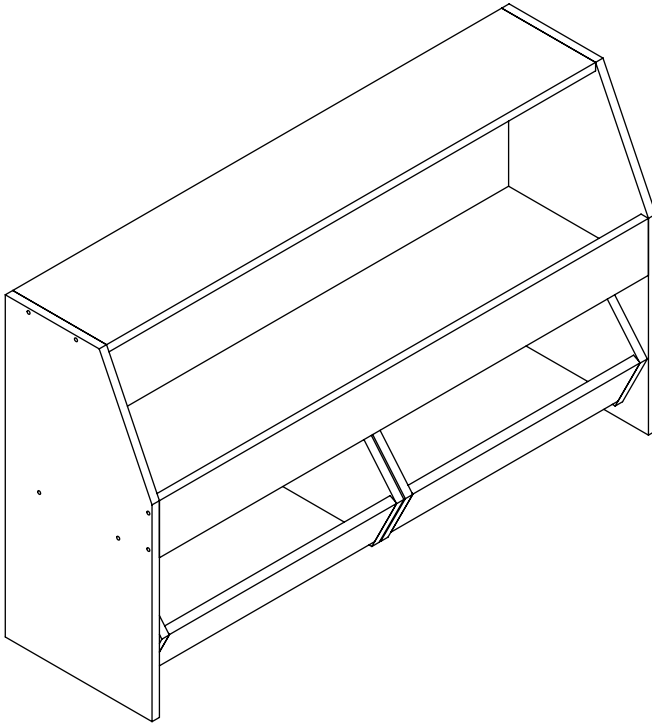
MODEL:ZD-25A01



This is the original instruction, please read all manual instructions carefully before operating. VEVOR reserves a clear interpretation of our user manual. The appearance of the product shall be subject to the product you received. Please forgive us that we won't inform you again if there are any technology or software updates on our product.

	<p>Warning-To reduce the risk of injury, user must read instructions manual carefully.</p> <p>Note: Adult assembly required !</p>
	<p>Compliance is a CE security certification.</p>
<p>Ages</p>	<p>3 Years +</p>

SAFETY INSTRUCTIONS

WARNING:

Read this material before using this product. Failure to do so may result in serious injury.

Assembly precautions







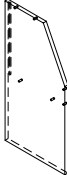
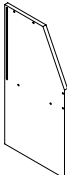
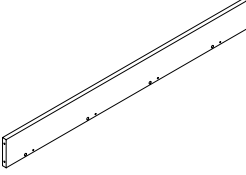
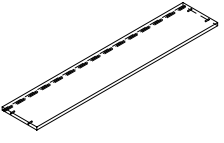
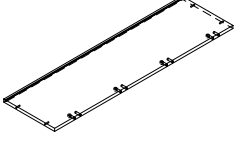
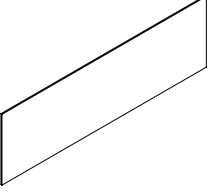
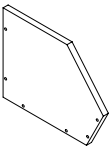
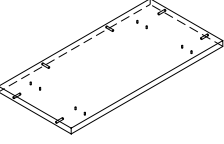
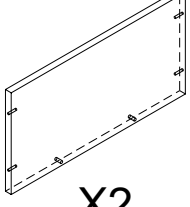
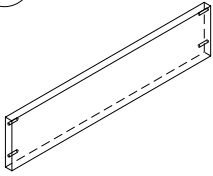

1. Assemble only according to these instructions. Improper assembly may create hazards.
2. Keep the assembly area clean and well-lit.
3. The product capabilities apply to properly and completely assembled products only.
4. Assemble on a flat, level, hard and smooth surface capable of safely supporting the Kids Storage Cubes.
5. For additional information regarding the parts listed in the following pages, please refer to the Assembly Diagram of this manual. Unwrap and separate all parts in a clean work area.

Use precautions

1. DO NOT SIT OR STAND ON THIS ITEM.
2. This product is not a toy. Do not allow children to play with or near this item.
3. Do not exceed specified weight capacities.
4. Use only on a flat, level, hard, and smooth surface that can safely support a fully loaded Kids Storage Cubes.
5. Use as intended only.
6. Inspect before every use; do not use if parts are loose or damaged.

SAVE THIS MANUAL



PARTS LIST

<p>①</p>  <p style="text-align: center; font-weight: bold;">X1</p>	<p>②</p>  <p style="text-align: center; font-weight: bold;">X1</p>	<p>③</p>  <p style="text-align: center; font-weight: bold;">X1</p>	<p>④</p>  <p style="text-align: center; font-weight: bold;">X1</p>				
<p>⑤</p>  <p style="text-align: center; font-weight: bold;">X1</p>	<p>⑥</p>  <p style="text-align: center; font-weight: bold;">X1</p>	<p>⑦</p>  <p style="text-align: center; font-weight: bold;">X4</p>	<p>⑧</p>  <p style="text-align: center; font-weight: bold;">X2</p>				
<p>⑨</p>  <p style="text-align: center; font-weight: bold;">X2</p>	<p>⑩</p>  <p style="text-align: center; font-weight: bold;">X2</p>						
A		5X35mm	X36	E			X1
B			X1	F			X8
C			X8	G			X8
D		3.5X8mm	X16	H		Φ8X35mm	X4

ASSEMBLY STEP

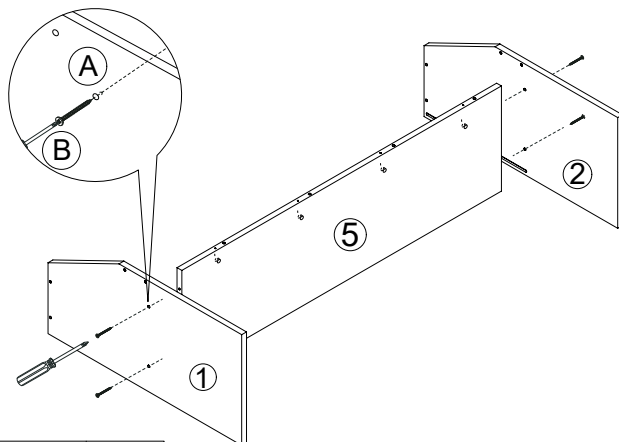
1





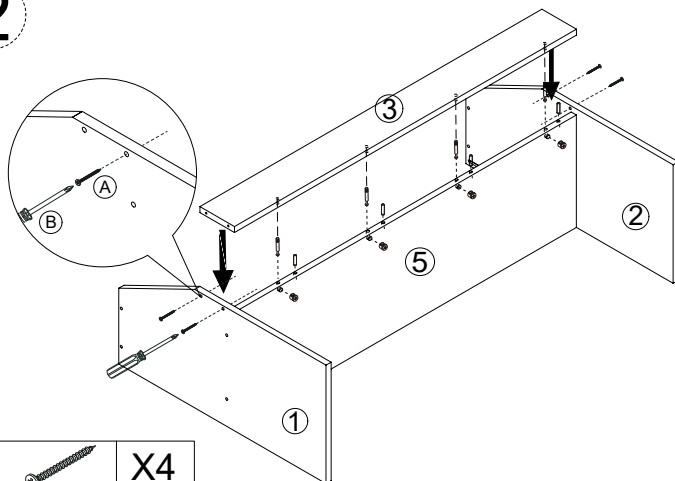

A		X4
B		X1

Don't tighten all the screws until the product is fully assembled!

2



A		X4
B		X1

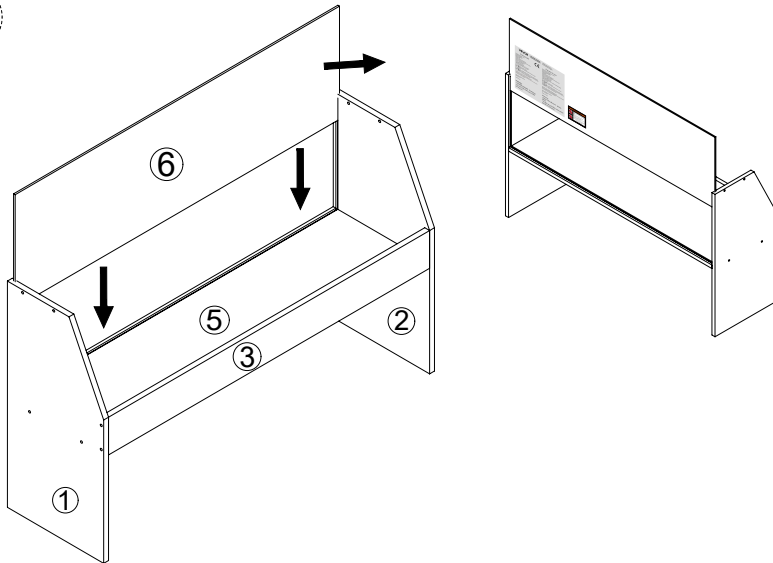

F		X4	G		X4	H		X4
---	---	----	---	---	----	---	---	----

3

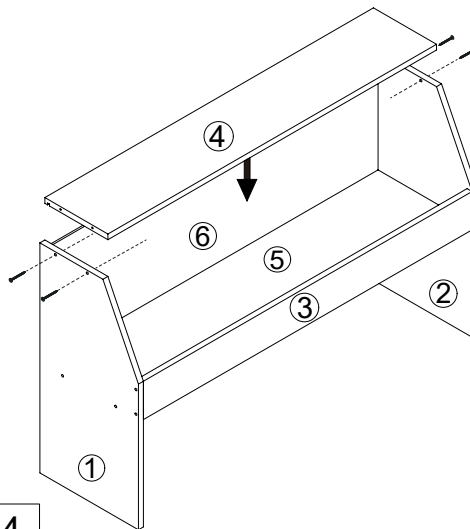

4



A		X4
B		X1

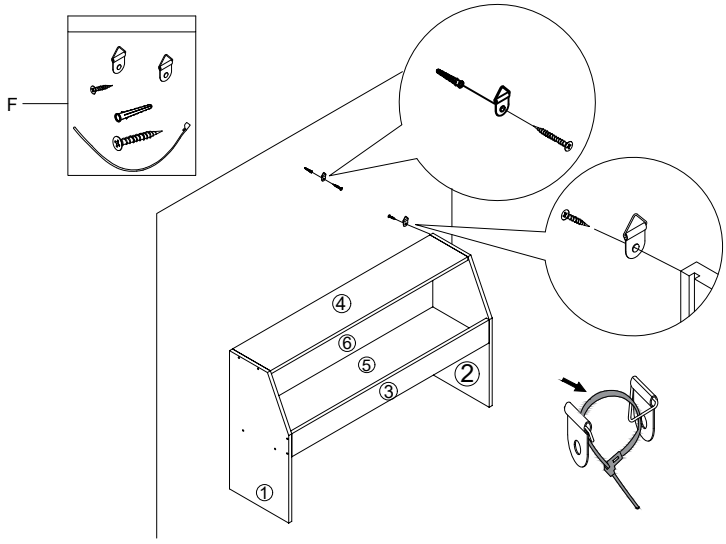

5



F		X1
---	---	----

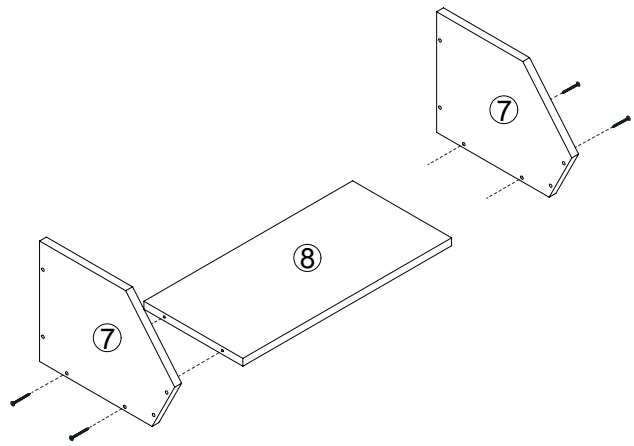



6

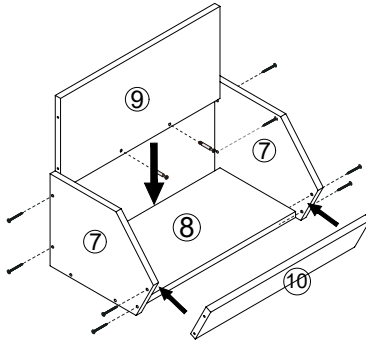

A		X4
B		X1



7

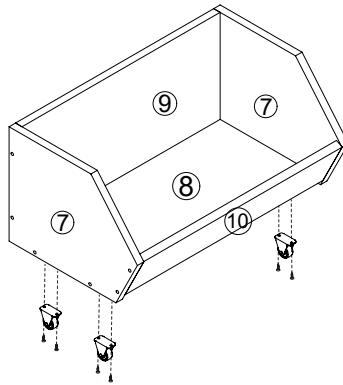

A		X8
B		X1
F		X2
G		X2

8



C		X4
D		X8
B		X1

9

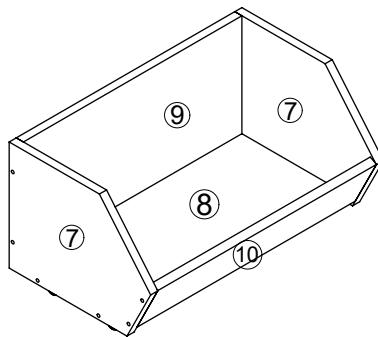

10

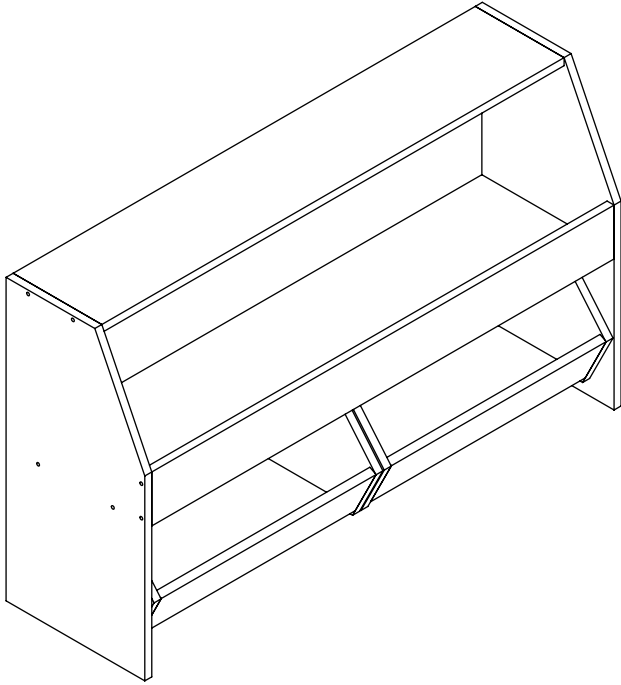

PRODUCT PARAMETER

Model	ZD-25A01
Number Of Storage Compartments	3
Colour	White
Product Size	1020*297*600mm

⚠ WARNING



Children have died from furniture tipover. To reduce the risk of furniture tipover:

- ALWAYS install Anti-tip device provided.
- NEVER put a TV on this product.
- NEVER allow children to stand, climb or hang on drawers, doors, or shelves.
- NEVER open more than one drawer at a time.
- Place heaviest items in the lowest drawers.

***This is a permanent label.
Do not remove!***

Manufacturer: Shanghaimuxinmuyeyouxiangongsi

Address: Shuangchenglu 803nong11hao1602A-1609shi, baoshanqu, shanghai 200000 CN.

Imported to AUS: SIHAO PTY LTD. 1 ROKEVA STREETEASTWOOD NSW 2122 Australia

Imported to USA: Sanven Technology Ltd. Suite 250, 9166 Anaheim Place, Rancho Cucamonga, CA 91730

UK	REP
-----------	------------

YH CONSULTING LIMITED. C/O YH Consulting Limited Office 147, Centurion House, London Road, Staines-upon-Thames, Surrey, TW18 4AX

EC	REP
-----------	------------

E-CrossStu GmbH
Mainzer Landstr.69,
60329 Frankfurt am Main.



VEVOR

Affordable. Reliable. Home Improvement.



CUBES DE RANGEMENT POUR ENFANTS

MODÈLE : ZD-25A01

VEVOR



Affordable. Reliable. Home Improvement.

KIDS STORAGE CUBES

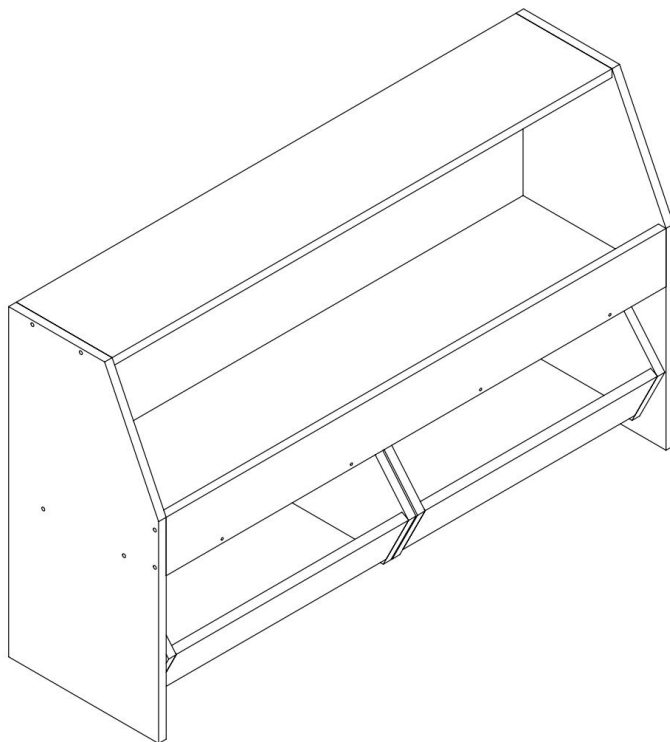
MODÈLE : ZD-25A01



Ceci est le mode d'emploi d'origine. Veuillez lire attentivement l'intégralité du manuel avant utilisation. VEVOR se réserve le droit d'interpréter clairement ce manuel d'utilisation. L'apparence du produit dépend du produit que vous avez reçu. Veuillez nous excuser pour les éventuelles mises à jour technologiques ou logicielles.

	Avertissement - Pour réduire le risque de blessure, l'utilisateur doit lire attentivement le manuel d'instructions . Remarque : assemblage par un adulte requis !
	La conformité est une certification de sécurité CE .
Âge	3 ans et plus

SAFETY INSTRUCTIONS

AVERTISSEMENT:

Veillez lire ce document avant d'utiliser ce produit. Le non-respect de ces instructions peut entraîner des blessures graves.

Précautions de montage

1. Assemblez uniquement conformément à ces instructions. Un assemblage incorrect peut créer des dangers.
2. Gardez la zone de montage propre et bien éclairée.
3. Les capacités du produit s'appliquent uniquement aux produits correctement et entièrement assemblés.
4. Assemblez-les sur une surface plane, de niveau, dure et lisse capable de supporter en toute sécurité les cubes de rangement pour enfants.
5. Pour plus d'informations sur les pièces listées dans les pages suivantes, veuillez vous référer au schéma d'assemblage de ce manuel. Déballez et séparez toutes les pièces dans un espace de travail propre.











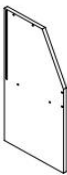

Précautions d'emploi

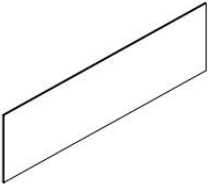
1. NE PAS S'ASSEOIR NI SE TENIR DEBOUT SUR CET ARTICLE.
2. Ce produit n'est pas un jouet. Ne laissez pas les enfants jouer avec ou à proximité de cet article.
3. Ne pas dépasser la dose spécifiée capacités de poids.
4. Utiliser uniquement sur une surface plane, de niveau, dure et lisse pouvant supporter en toute sécurité des cubes de rangement pour enfants entièrement chargés.
5. Utiliser uniquement comme prévu.
6. Inspectez avant chaque utilisation ; ne pas utiliser si des pièces sont

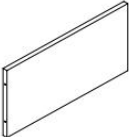
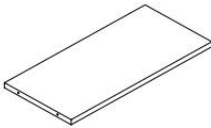
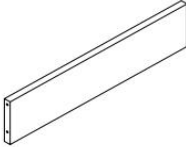
desserrées ou endommagées.

CONSERVEZ CE MANUEL

PARTS LIST

①		X1	②		X1	③		X1	④		X1
⑤		X1	⑥		X1	⑦		X4	⑧		X2
⑨		X2	⑩		X2						
A		5X35mm	X40	F				X1			
B			X1								
C			X8								
D		3.5X8mm	X16								

ASSEMBLY STEP

1

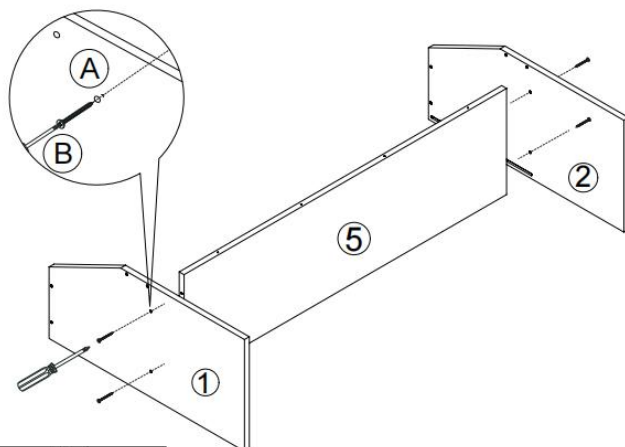

A		X4
B		X1

2

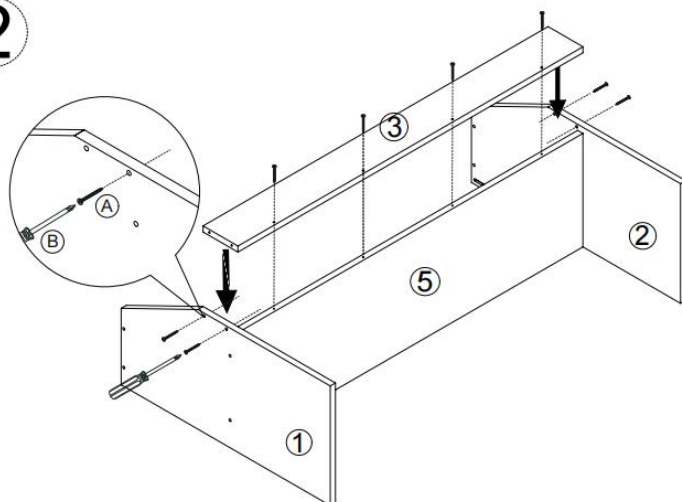

A		X8
B		X1

3

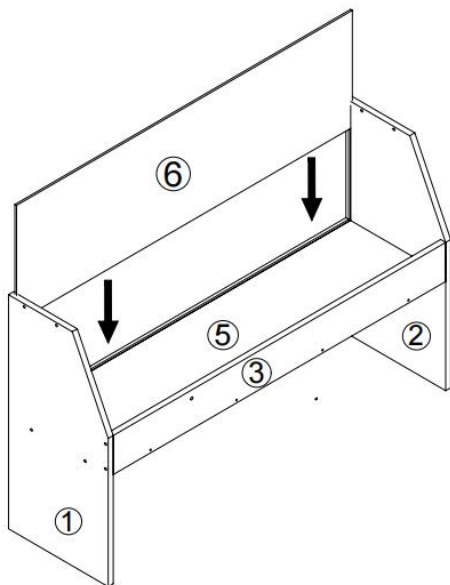

4

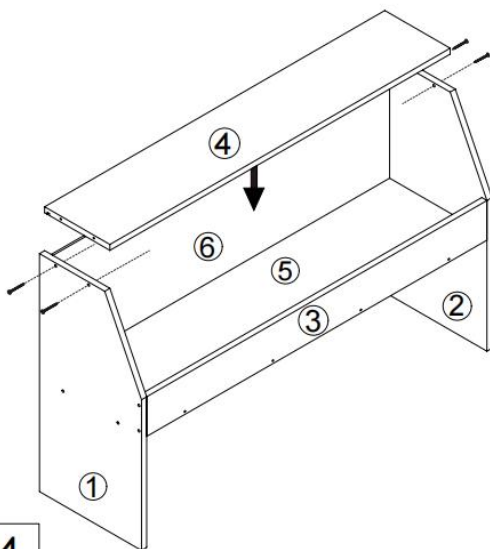

A		X4
B		X1

5

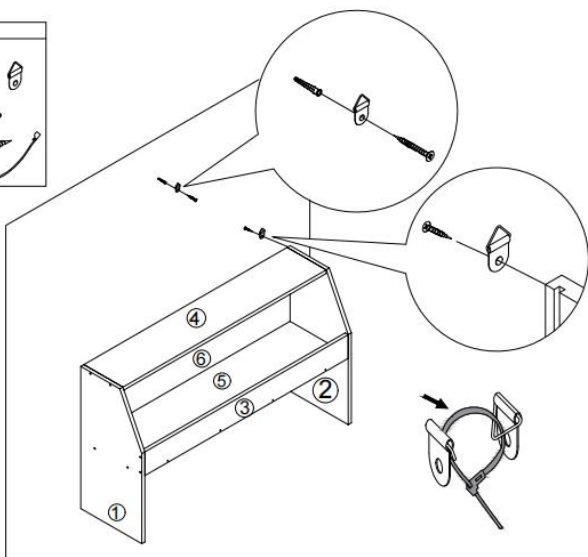
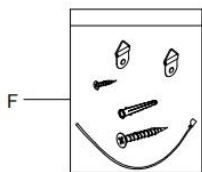

F



X1

6

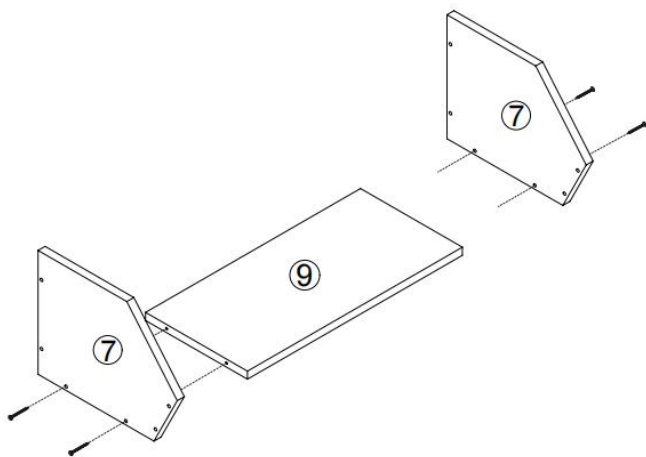

A



X4

B



X1

7

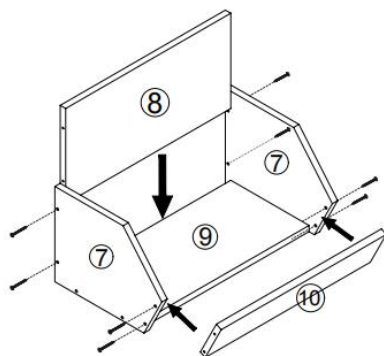

A		X8
B		X1

8

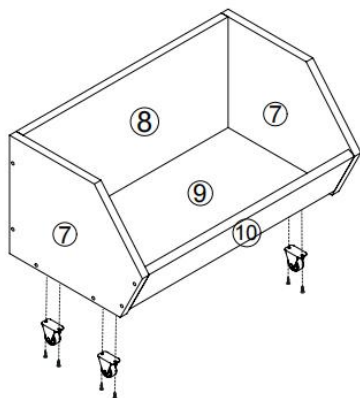

D		X8
B		X1

9

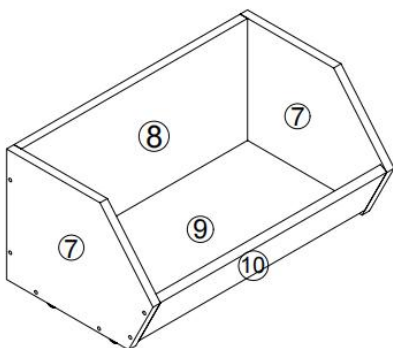

10

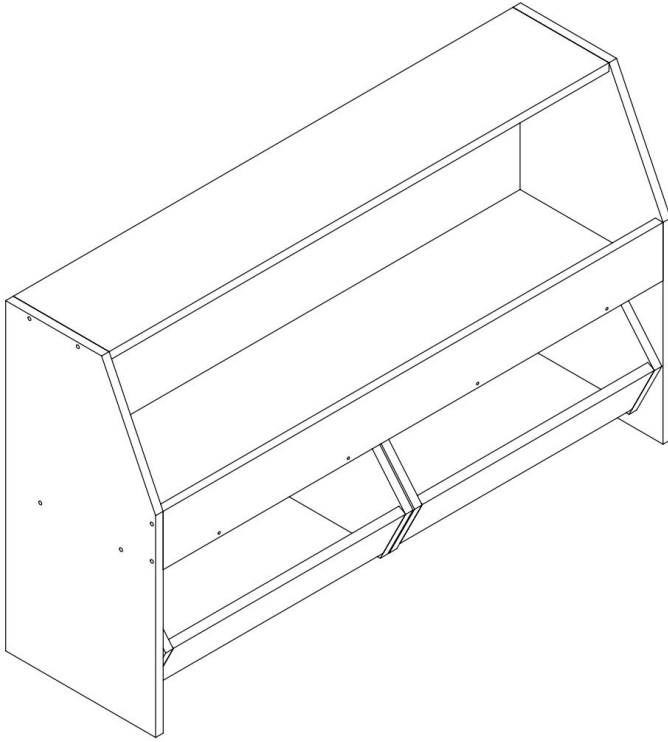

PRODUCT PARAMETER

Modèle	ZD-25A01
Nombre de compartiments de rangement	3
Couleur	Blanc
Taille du produit	1020 * 297 * 600mm

⚠ WARNING

	<p>Children have died from furniture tipover. To reduce the risk of furniture tipover:</p> <ul style="list-style-type: none">● ALWAYS install Anti-tip device provided.● NEVER put a TV on this product.● NEVER allow children to stand, climb or hang on drawers, doors, or shelves.● NEVER open more than one drawer at a time.● Place heaviest items in the lowest drawers. <p style="text-align: center;"><i>This is a permanent label. Do not remove!</i></p>
	

Fabricant : Shanghaimuxinmuyeyouxiangongsi

Adresse : Shuangchenglu 803nong11hao1602A-1609shi, baoshanqu, Shanghai 200 000 CN.

Importé en Australie : SIHAO PTY LTD. 1 ROKEVA STREET, ASTWOOD NSW 2122 Australie

Importé aux États-Unis : Sanven Technology Ltd. Suite 250, 9166 Anaheim

Lieu, Rancho Cucamonga, CA 91730

UK	REP
-----------	------------

YH CONSULTING LIMITED. C/O YH Consulting Limited Office 147, Centurion House, London Road, Staines-upon-Thames, Surrey, TW18 4AX

EC	REP
-----------	------------

E-CrossStu GmbH
Mainzer Landstr.69,
60329 Frankfurt am Main.



VEVOR

Affordable. Reliable. Home Improvement.





AUFBEWAHRUNGSWÜRFEL FÜR KINDER

MODELL: ZD-25A01

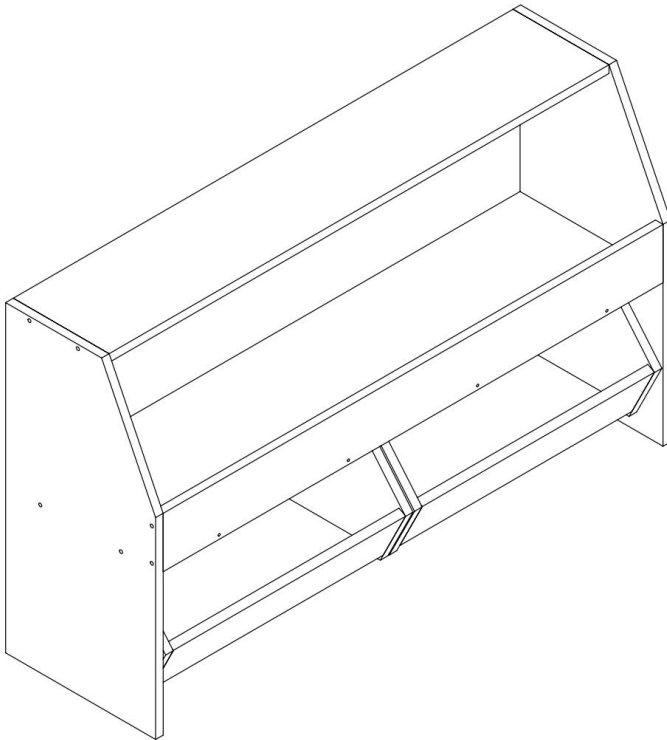
MODELL: ZD-25A01



Dies ist die Originalanleitung. Bitte lesen Sie alle Anweisungen sorgfältig durch, bevor Sie das Gerät in Betrieb nehmen. VEVOR behält sich das Recht vor, die Bedienungsanleitung klar und deutlich zu interpretieren. Das Aussehen des Produkts hängt vom gelieferten Produkt ab. Bitte haben Sie Verständnis dafür, dass wir Sie nicht erneut über Technologie- oder Software-Updates informieren.

	<p>Warnung: Um das Verletzungsrisiko zu verringern, muss der Benutzer die Bedienungsanleitung sorgfältig lesen . Hinweis: Montage durch Erwachsene erforderlich !</p>
	<p>Compliance ist eine CE- Sicherheitszertifizierung .</p>
<p>Alter</p>	<p>Ab 3 Jahren</p>

SAFETY INSTRUCTIONS

WARNUNG:

Lesen Sie dieses Material, bevor Sie dieses Produkt verwenden. Andernfalls kann es zu schweren Verletzungen kommen.

Vorsichtsmaßnahmen bei der Montage

6. Führen Sie die Montage ausschließlich gemäß dieser Anleitung durch. Eine unsachgemäße Montage kann zu Gefahren führen.
7. Halten Sie den Versammlungsbereich sauber und gut beleuchtet.
8. Die Produkteigenschaften gelten nur für ordnungsgemäß und vollständig montierte Produkte.
9. Montieren Sie die Einheit auf einer flachen, ebenen, harten und glatten Oberfläche, auf der die Kids Storage Cubes sicher stehen können.
10. Weitere Informationen zu den auf den folgenden Seiten aufgeführten Teilen finden Sie im Montagediagramm dieses Handbuchs. Packen Sie alle Teile an einem sauberen Arbeitsbereich aus und trennen Sie sie.











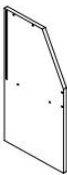

Vorsichtsmaßnahmen treffen

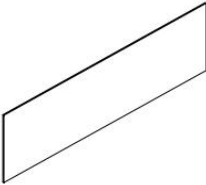
7. SITZEN ODER STEHEN SIE NICHT AUF DIESEM ARTIKEL.
8. Dieses Produkt ist kein Spielzeug. Erlauben Sie Kindern nicht, mit diesem Artikel oder in dessen Nähe zu spielen.
9. Überschreiten Sie nicht die angegebene Gewichtskapazitäten.
10. Nur auf einer flachen, ebenen, harten und glatten Oberfläche verwenden, die einen vollständig beladenen Kids Storage Cube sicher tragen kann.
11. Nur bestimmungsgemäß verwenden.
12. Vor jedem Gebrauch prüfen; nicht verwenden, wenn Teile lose oder

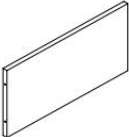
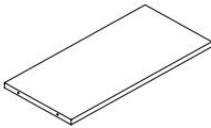
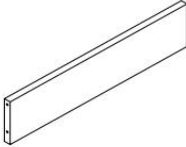
beschädigt sind.

BEWAHREN SIE DIESES HANDBUCH AUF

PARTS LIST

①		X1	②		X1	③		X1	④		X1
⑤		X1	⑥		X1	⑦		X4	⑧		X2
⑨		X2	⑩		X2						
A		5X35mm	X40	F				X1			
B			X1								
C			X8								
D		3.5X8mm	X16								

ASSEMBLY STEP

1

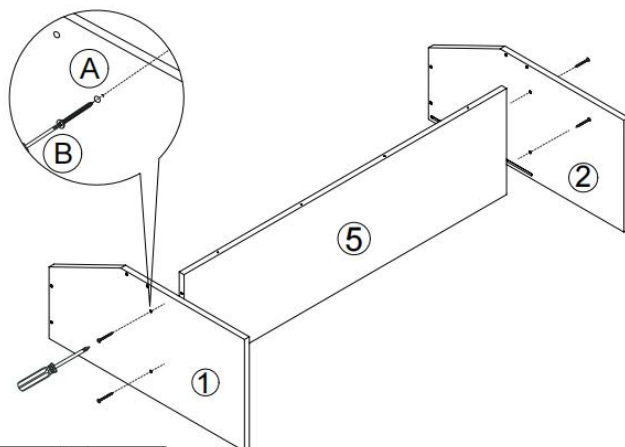

A		X4
B		X1

2

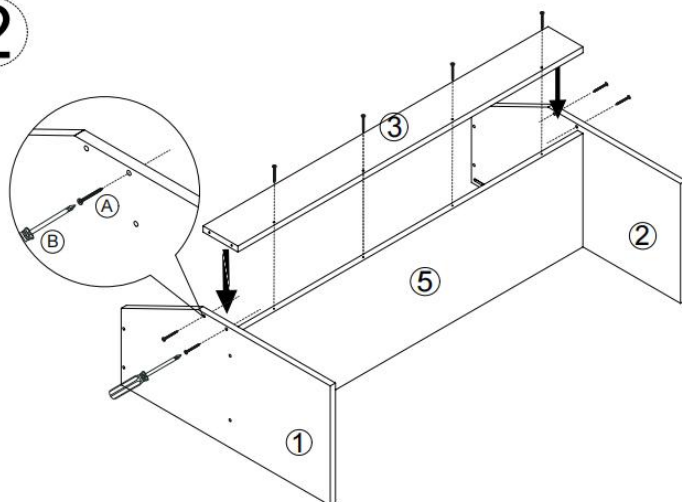

A		X8
B		X1

3

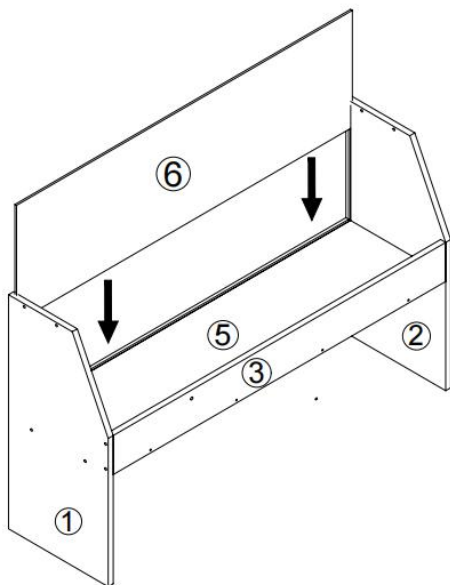

4

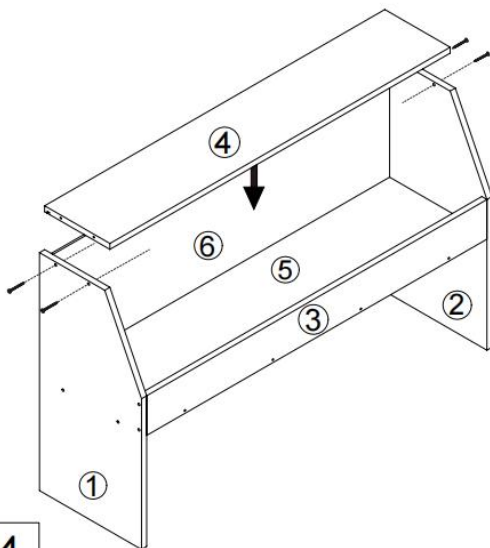

A



X4

B



X1

5

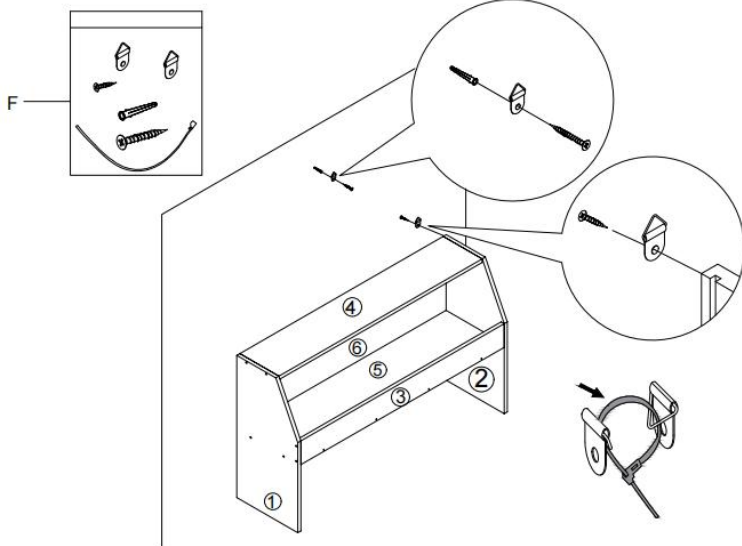

F



X1

6

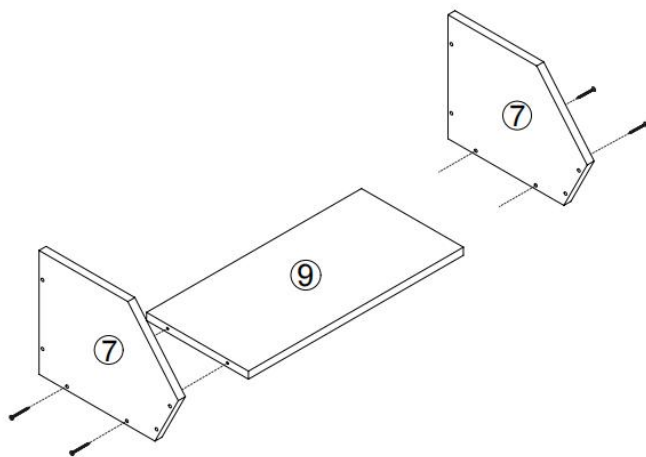

A



X4

B



X1

7

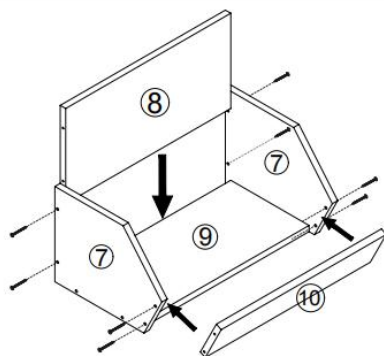

A		X8
B		X1

8

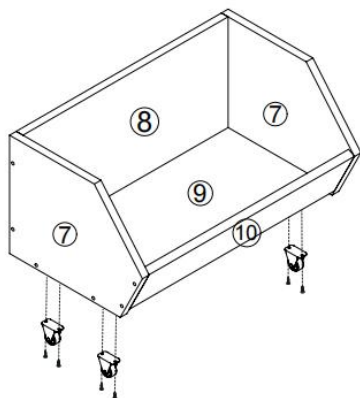

D		X8
B		X1

9

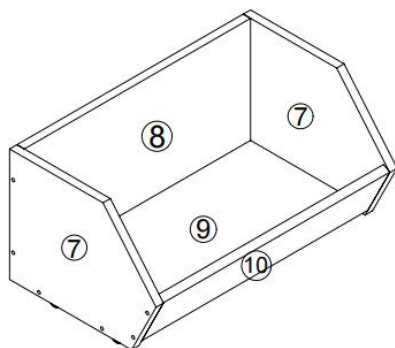

10

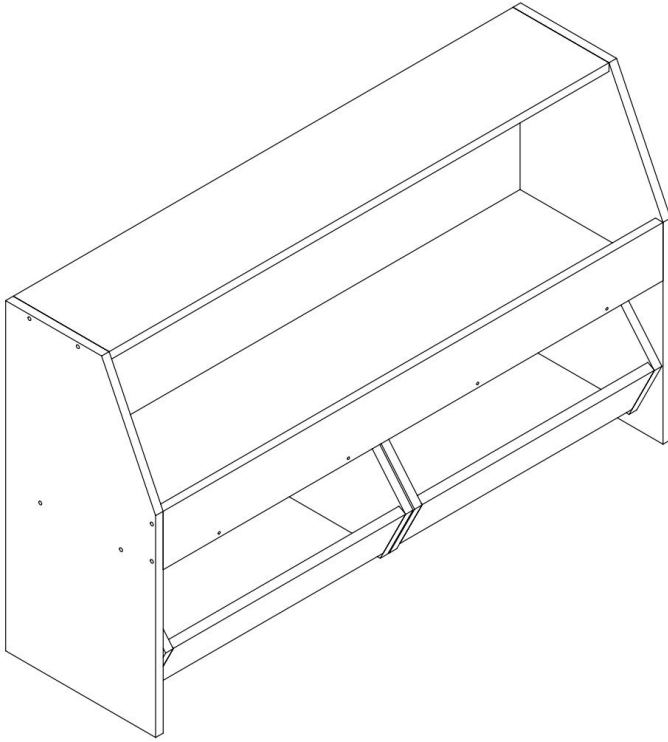

PRODUCT PARAMETER

Modell	ZD-25A01
Anzahl der Lagerfächer	3
Farbe	Weiß
Produktgröße	1020 * 297 * 600 mm

⚠ WARNING



Children have died from furniture tipover. To reduce the risk of furniture tipover:

- ALWAYS install Anti-tip device provided.
- NEVER put a TV on this product.
- NEVER allow children to stand, climb or hang on drawers, doors, or shelves.
- NEVER open more than one drawer at a time.
- Place heaviest items in the lowest drawers.

***This is a permanent label.
Do not remove!***

Hersteller: Shanghai muxinmuyeyouxiangongsi

Adresse: Shuangchenglu 803nong11hao1602A-1609shi, baoshanqu, Shanghai 200.000 CN.

Importiert nach AUS: SIHAO PTY LTD. 1 ROKEVA STREETEASTWOOD NSW 2122 Australien

Importiert in die USA: Sanven Technology Ltd. Suite 250, 9166 Anaheim Place, Rancho Cucamonga, CA 91730

UK	REP
-----------	------------

YH CONSULTING LIMITED. C/O YH Consulting Limited Office 147, Centurion House, London Road, Staines-upon-Thames, Surrey, TW18 4AX

EC	REP
-----------	------------

E-CrossStu GmbH
Mainzer Landstr.69,
60329 Frankfurt am Main.



VEVOR

Affordable. Reliable. Home Improvement.





CUBI PORTAOGGETTI PER BAMBINI

MODELLO: ZD-25A01

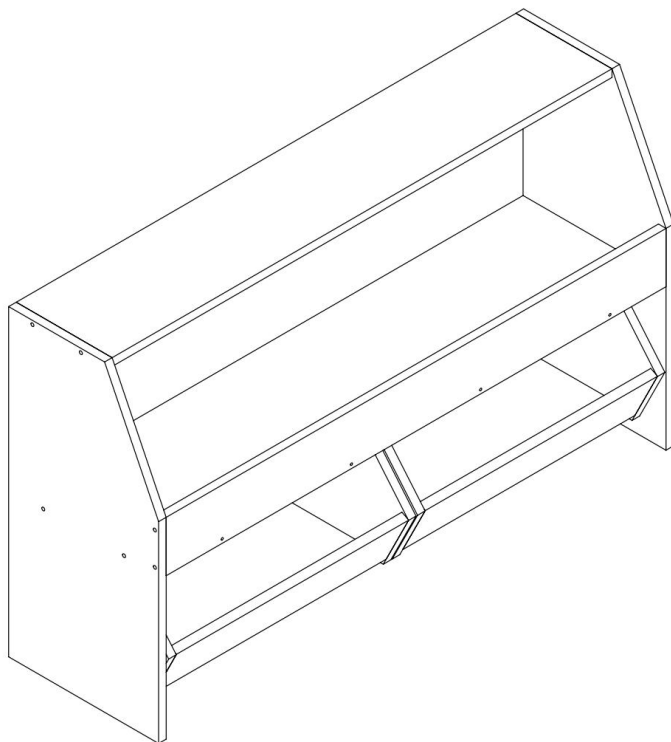
MODELLO: ZD-25A01



Queste sono le istruzioni originali, si prega di leggere attentamente tutte le istruzioni del manuale prima di utilizzare il prodotto. VEVOR si riserva la piena interpretazione del manuale utente. L'aspetto del prodotto dipenderà dal prodotto ricevuto. Vi preghiamo di non informarvi ulteriormente in caso di aggiornamenti tecnologici o software relativi al nostro prodotto.

	<p>Avvertenza: per ridurre il rischio di lesioni, l'utente deve leggere attentamente il manuale di istruzioni .</p> <p>Nota: è richiesto il montaggio da parte di un adulto !</p>
	<p>La conformità è una certificazione di sicurezza C E.</p>
<p>Età</p>	<p>3 anni +</p>

SAFETY INSTRUCTIONS

AVVERTIMENTO:

Leggere attentamente questo materiale prima di utilizzare il prodotto. La mancata osservanza di queste istruzioni può causare gravi lesioni.

Precauzioni di montaggio











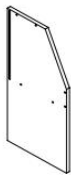

11. Montare solo secondo queste istruzioni. Un montaggio improprio può comportare pericoli.
12. Mantenere l'area di riunione pulita e ben illuminata.
13. Le capacità del prodotto si applicano solo ai prodotti correttamente e completamente assemblati.
14. Montare su una superficie piana, livellata, dura e liscia, in grado di sostenere in modo sicuro i cubi portaoggetti per bambini.
15. Per ulteriori informazioni sui componenti elencati nelle pagine seguenti, fare riferimento allo schema di montaggio di questo manuale.
Disimballare e separare tutti i componenti in un'area di lavoro pulita.

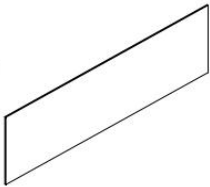
Usare precauzioni

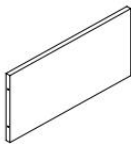
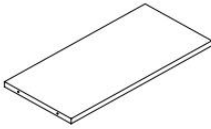
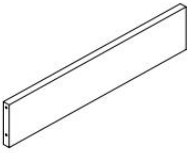
13. NON SEDERSI O STARE IN PIEDI SU QUESTO OGGETTO.
14. Questo prodotto non è un giocattolo. Non permettere ai bambini di giocare con questo articolo o nelle sue vicinanze.
15. Non superare il limite specificato capacità di peso.
16. Utilizzare solo su una superficie piana, livellata, dura e liscia in grado di sostenere in sicurezza un Kids Storage Cube completamente carico.
17. Da utilizzare solo come previsto.
18. Controllare prima di ogni utilizzo; non utilizzare se alcune parti risultano allentate o danneggiate.

CONSERVARE QUESTO MANUALE

PARTS LIST

<p>①</p>  <p>X1</p>	<p>②</p>  <p>X1</p>	<p>③</p>  <p>X1</p>	<p>④</p>  <p>X1</p>				
<p>⑤</p>  <p>X1</p>	<p>⑥</p>  <p>X1</p>	<p>⑦</p>  <p>X4</p>	<p>⑧</p>  <p>X2</p>				
<p>⑨</p>  <p>X2</p>	<p>⑩</p>  <p>X2</p>						
<p>A</p> 	<p>5X35mm</p>	<p>X40</p>	<p>F</p>				<p>X1</p>
<p>B</p> 		<p>X1</p>					
<p>C</p> 		<p>X8</p>					
<p>D</p> 	<p>3.5X8mm</p>	<p>X16</p>					

ASSEMBLY STEP

1

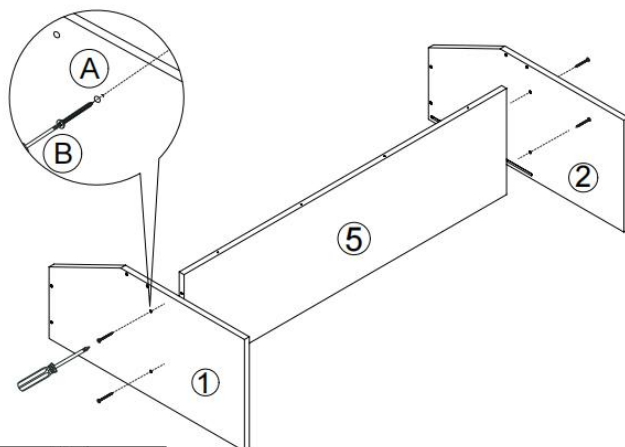

A		X4
B		X1

2

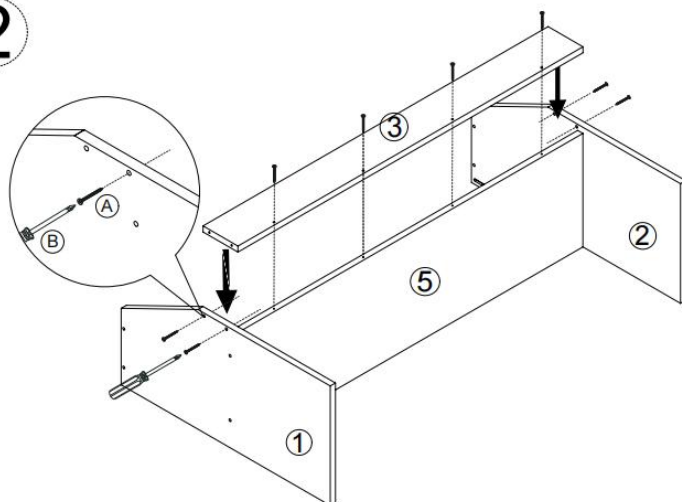

A		X8
B		X1

3

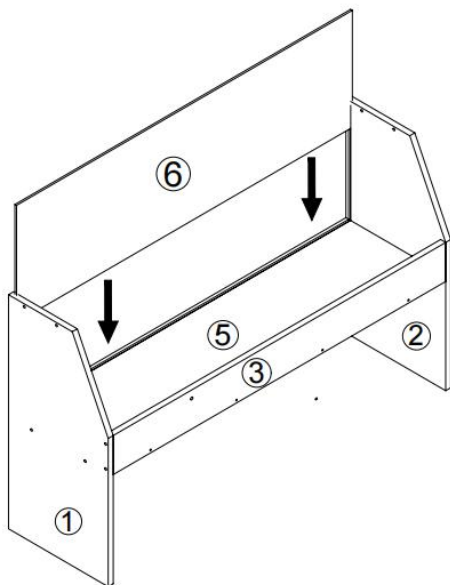

4

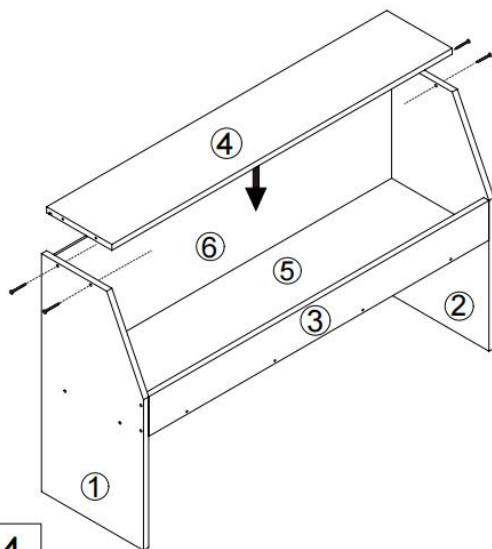

A		X4
B		X1

5

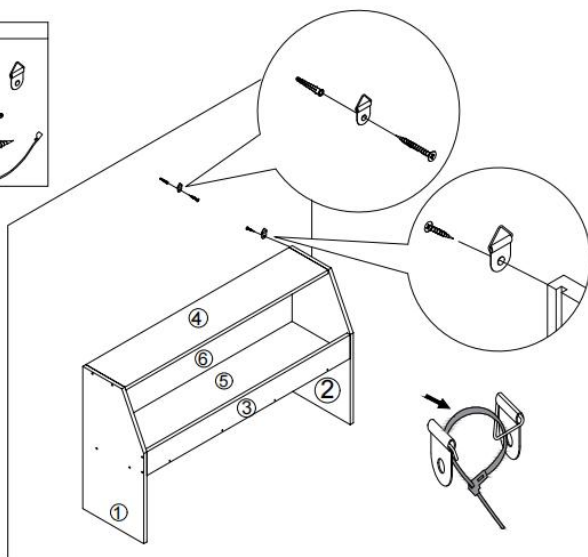
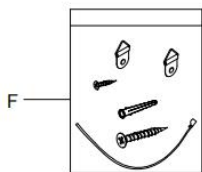

F



X1

6

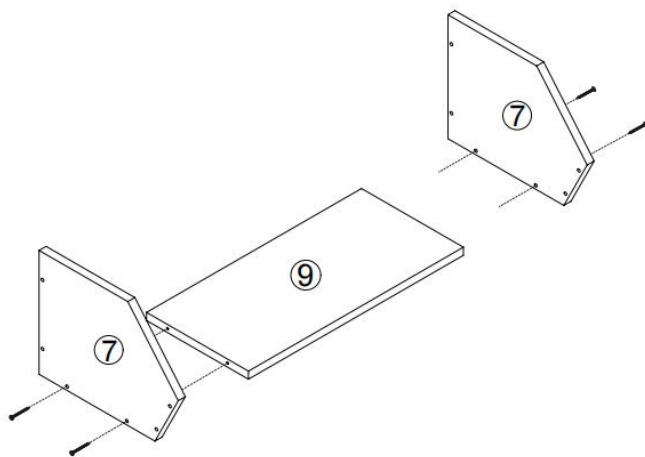

A



X4

B



X1

7

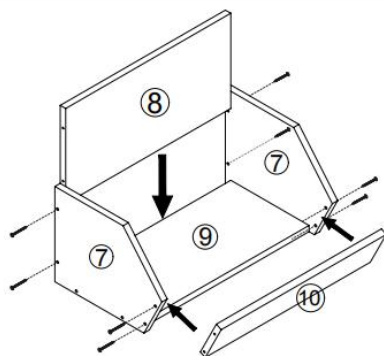

A		X8
B		X1

8

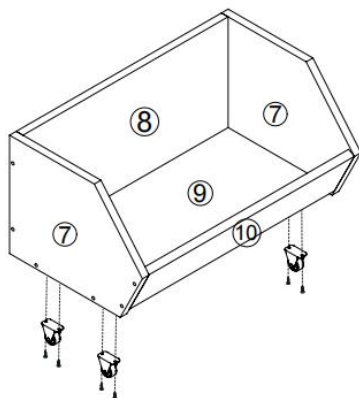

D		X8
B		X1

9

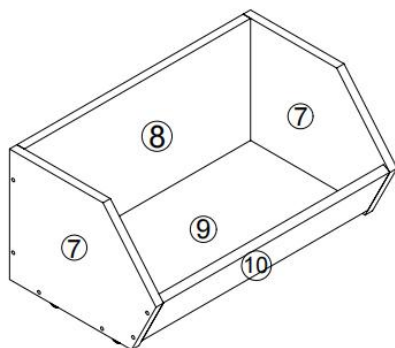

10

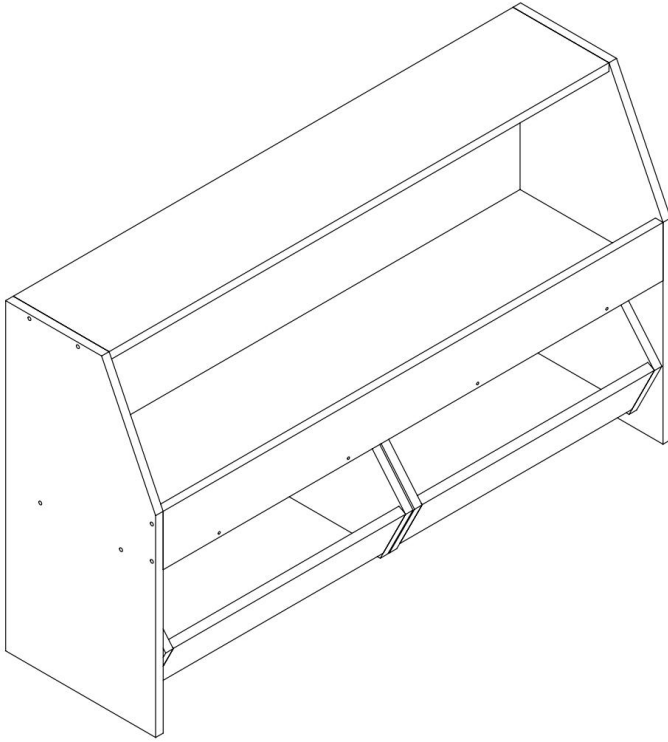

PRODUCT PARAMETER

Modello	ZD-25A01
Numero di scomparti di stoccaggio	3
Colore	Bianco
Dimensioni del prodotto	1020 * 297 * 600 mm

⚠ WARNING



Children have died from furniture tipover. To reduce the risk of furniture tipover:

- ALWAYS install Anti-tip device provided.
- NEVER put a TV on this product.
- NEVER allow children to stand, climb or hang on drawers, doors, or shelves.
- NEVER open more than one drawer at a time.
- Place heaviest items in the lowest drawers.

***This is a permanent label.
Do not remove!***

Produttore: Shanghaimuxinmuyeyouxiangongsi

Indirizzo: Shuangchenglu 803nong11hao1602A-1609shi, baoshanqu, shanghai 200000 CN.

Importato in AUS: SIHAO PTY LTD. 1 ROKEVA STREETEASTWOOD
Nuovo Galles del Sud 2122 Australia

Importato negli USA: Sanven Technology Ltd. Suite 250, 9166 Anaheim
Luogo, Rancho Cucamonga, CA 91730

UK	REP
-----------	------------

YH CONSULTING LIMITED. C/O YH Consulting
Limited Office 147, Centurion House, London
Road, Staines-upon-Thames, Surrey, TW18 4AX

EC	REP
-----------	------------

E-CrossStu GmbH
Mainzer Landstr.69,
60329 Frankfurt am Main.



VEVOR

Affordable. Reliable. Home Improvement.





**CUBOS DE ALMACENAMIENTO PARA
NIÑOS**

MODELO: ZD-25A01

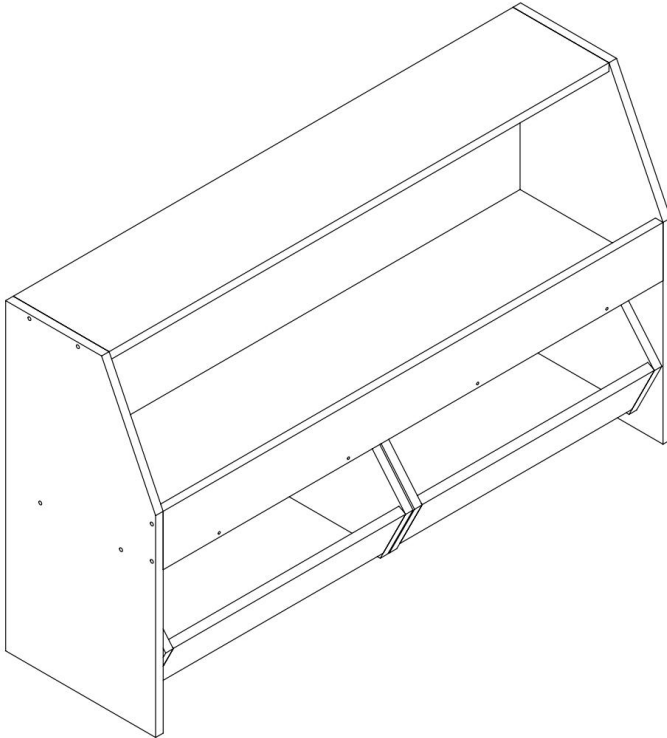
MODELO: ZD-25A01



Estas son las instrucciones originales; lea atentamente todas las instrucciones del manual antes de utilizarlo. VEVOR se reserva el derecho de interpretar su manual de usuario. La apariencia del producto dependerá del producto que haya recibido. Le rogamos que nos disculpe si no le informamos de nuevo si hay actualizaciones tecnológicas o de software en nuestro producto.

	<p>Advertencia: Para reducir el riesgo de lesiones, el usuario debe leer atentamente el manual de instrucciones .</p> <p>Nota: ¡ Requiere ensamblaje por parte de un adulto !</p>
	<p>Compliance es una certificación de seguridad CE .</p>
<p>Siglos</p>	<p>3 años +</p>

SAFETY INSTRUCTIONS

ADVERTENCIA:

Lea este material antes de usar este producto. De lo contrario, podría sufrir lesiones graves.

Precauciones de montaje

16. Ensamble únicamente según estas instrucciones. Un montaje incorrecto puede causar riesgos.
17. Mantenga el área de reunión limpia y bien iluminada.
18. Las capacidades del producto se aplican únicamente a productos ensamblados correcta y completamente.
19. Móntelo sobre una superficie plana, nivelada, dura y lisa capaz de soportar de forma segura los cubos de almacenamiento para niños.
20. Para obtener más información sobre las piezas que se enumeran en las páginas siguientes, consulte el diagrama de montaje de este manual. Desembale y separe todas las piezas en un área de trabajo limpia.











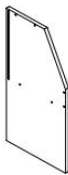

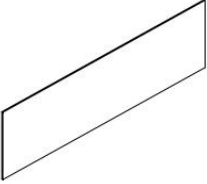

Precauciones de uso

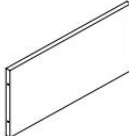
19. NO SE SIENTA NI SE PARE SOBRE ESTE ARTÍCULO.
20. Este producto no es un juguete. No permita que los niños jueguen con él ni lo acerquen.
21. No exceda lo especificado capacidades de peso.
22. Úselo solo sobre una superficie plana, nivelada, dura y lisa que pueda soportar de manera segura un Kids Storage Cubes completamente cargado.
23. Úselo únicamente según lo previsto.

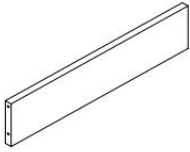
24. Inspeccione antes de cada uso; no lo utilice si las piezas están sueltas o dañadas.

GUARDE ESTE MANUAL

PARTS LIST

<p>①</p>  <p>X1</p>	<p>②</p>  <p>X1</p>	<p>③</p>  <p>X1</p>	<p>④</p>  <p>X1</p>				
<p>⑤</p>  <p>X1</p>	<p>⑥</p>  <p>X1</p>	<p>⑦</p>  <p>X4</p>	<p>⑧</p>  <p>X2</p>				
<p>⑨</p>  <p>X2</p>	<p>⑩</p>  <p>X2</p>						
<p>A</p> 	<p>5X35mm</p>	<p>X40</p>	<p>F</p>				<p>X1</p>
<p>B</p> 		<p>X1</p>					
<p>C</p> 		<p>X8</p>					
<p>D</p> 	<p>3.5X8mm</p>	<p>X16</p>					

ASSEMBLY STEP

1

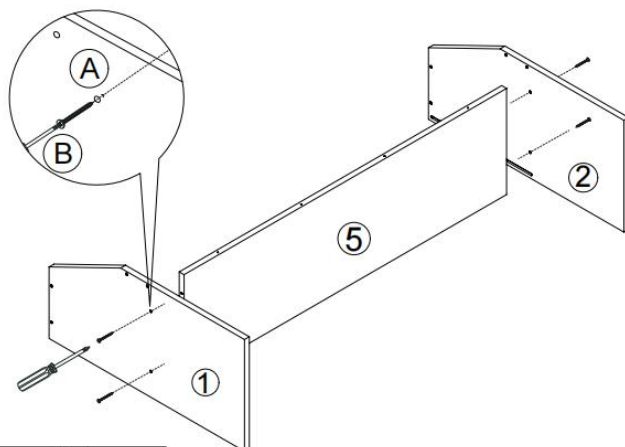

A		X4
B		X1

2

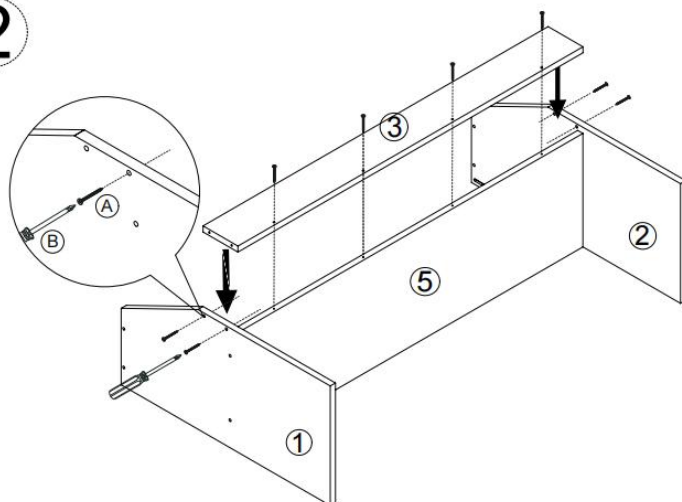

A		X8
B		X1

3

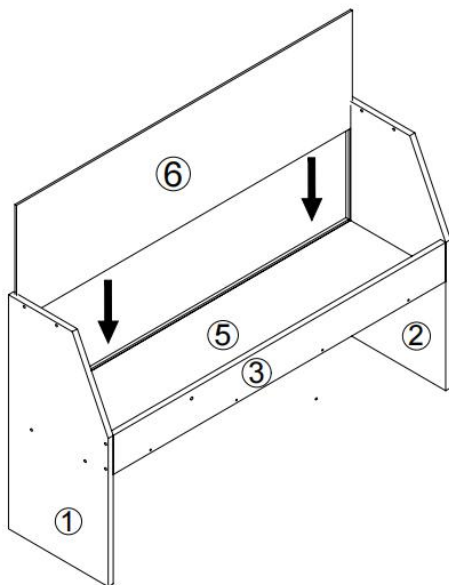

4

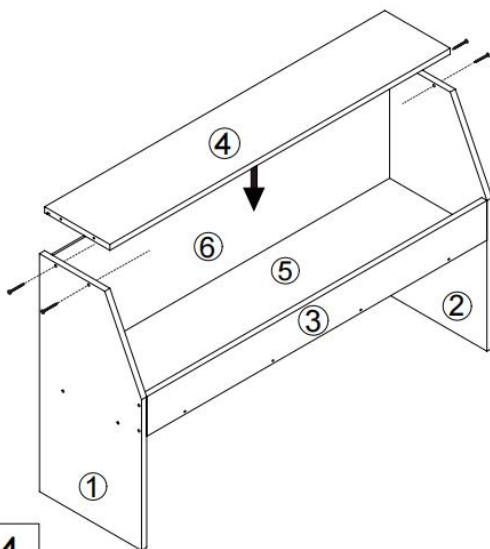

A



X4

B

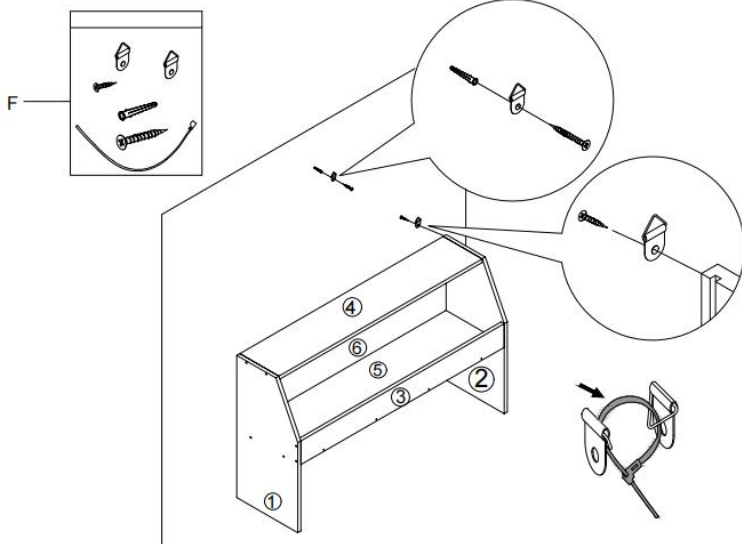

X1

5

F

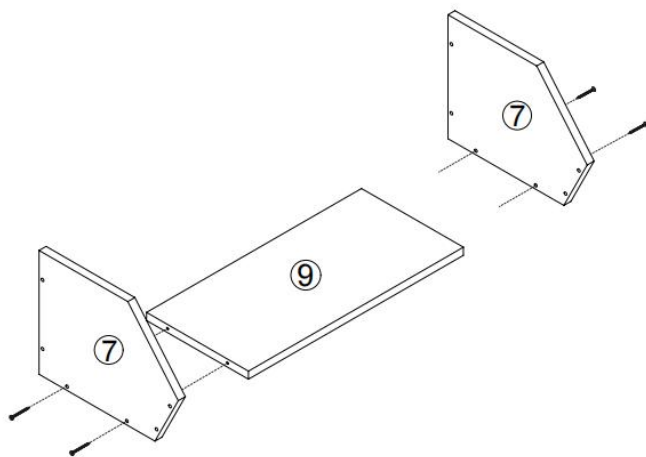

X1

6

A



X4

B



X1

7

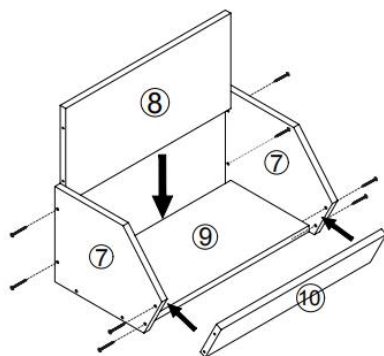

A		X8
B		X1

8

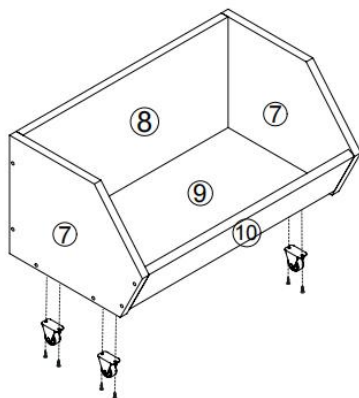

D		X8
B		X1

9

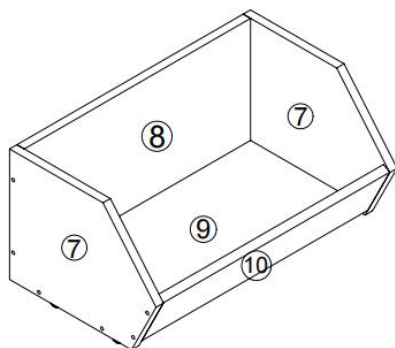

10

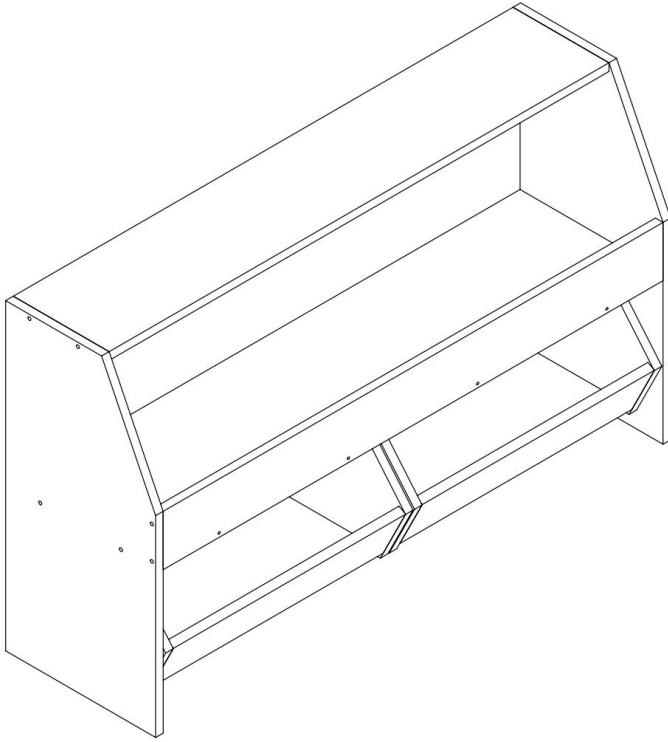

PRODUCT PARAMETER

Modelo	ZD-25A01
Número de compartimentos de almacenamiento	3
Color	Blanco
Tamaño del producto	1020 * 297 * 600 mm

⚠ WARNING

	<p>Children have died from furniture tipover. To reduce the risk of furniture tipover:</p> <ul style="list-style-type: none">● ALWAYS install Anti-tip device provided.● NEVER put a TV on this product.● NEVER allow children to stand, climb or hang on drawers, doors, or shelves.● NEVER open more than one drawer at a time.● Place heaviest items in the lowest drawers.
	<p style="text-align: center;"><i>This is a permanent label. Do not remove!</i></p>

Fabricante: Shanghaimuxinmuyeyouxiangongsi

Dirección: Shuangchenglu 803nong11hao1602A-1609shi, baoshanqu, Shanghai 200000 CN.

Importado a AUS: SIHAO PTY LTD. 1 ROKEVA STREET, EASTWOOD NSW 2122 Australia

Importado a EE. UU.: Sanven Technology Ltd. Suite 250, 9166 Anaheim Lugar, Rancho Cucamonga, CA 91730

UK	REP
-----------	------------

YH CONSULTING LIMITED. C/O YH Consulting Limited Office 147, Centurion House, London Road, Staines-upon-Thames, Surrey, TW18 4AX

EC	REP
-----------	------------

E-CrossStu GmbH
Mainzer Landstr.69,
60329 Frankfurt am Main.



VEVOR

Affordable. Reliable. Home Improvement.





**KOSTKI DO PRZECHOWYWANIA DLA
DZIECI**

MODELE: ZD-25A01

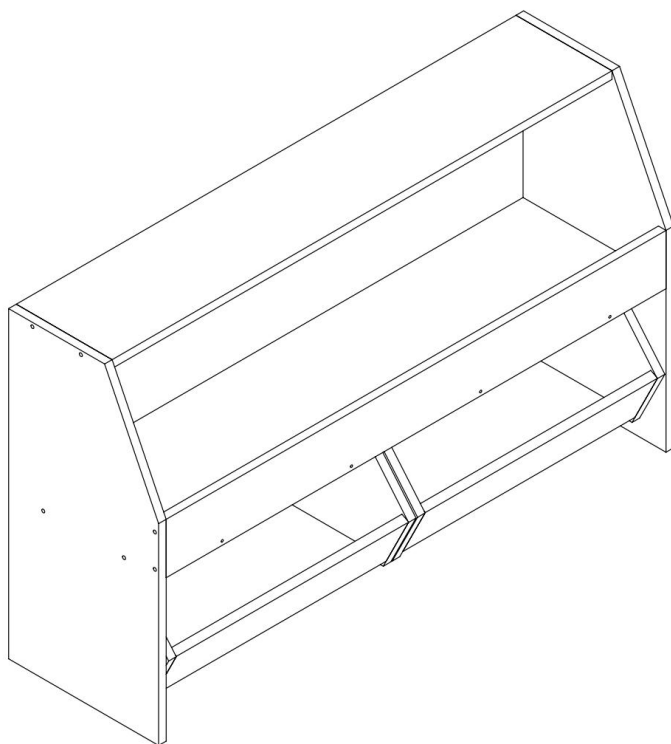
MODELE: ZD-25A01



To jest oryginalna instrukcja, przed użyciem należy uważnie przeczytać wszystkie instrukcje. VEVOR zastrzega sobie jasną interpretację naszej instrukcji obsługi. Wygląd produktu będzie zależał od produktu, który otrzymałeś. Prosimy o wybaczenie, że nie poinformujemy Cię ponownie, jeśli w naszym produkcie pojawią się jakiegokolwiek aktualizacje technologiczne lub oprogramowania.

	<p>Ostrzeżenie: Aby zminimalizować ryzyko obrażeń, użytkownik powinien uważnie przeczytać instrukcję obsługi . Uwaga: Wymagany montaż przez osobę dorosłą !</p>
	<p>Zgodność oznacza certyfikat bezpieczeństwa CE .</p>
<p>Wieczność</p>	<p>3 lata +</p>

SAFETY INSTRUCTIONS

OSTRZEŻENIE:

Przeczytaj ten materiał przed użyciem tego produktu.

Nieprzestrzeżenie tego może spowodować poważne obrażenia.

Środki ostrożności podczas montażu

21. Montaż należy wykonywać wyłącznie zgodnie z niniejszą instrukcją. Nieprawidłowy montaż może stwarzać zagrożenia.
22. Utrzymuj miejsce zgromadzenia w czystości i zapewnij dobre oświetlenie.
23. Możliwości produktu odnoszą się wyłącznie do produktów prawidłowo i kompletnie zmontowanych.
24. Złóż na płaskiej, równej, twardej i gładkiej powierzchni, która będzie w stanie bezpiecznie utrzymać dziecięce kostki do przechowywania.
25. Aby uzyskać dodatkowe informacje dotyczące części wymienionych na kolejnych stronach, zapoznaj się ze schematem montażu w tym podręczniku. Rozpakuj i oddziel wszystkie części w czystym miejscu pracy.











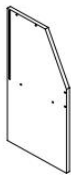

Stosuj środki ostrożności

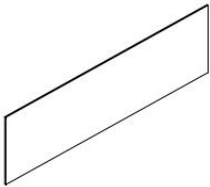
25. **NIE SIADAĆ ANI NIE STAWAĆ NA TYM PRZEDMIOCIE.**
26. Ten produkt nie jest zabawką. Nie pozwalaj dzieciom bawić się tym przedmiotem ani przebywać w jego pobliżu.
27. Nie przekraczać określonej wartości nośności.
28. Używaj wyłącznie na płaskiej, równej, twardej i gładkiej powierzchni, która może bezpiecznie utrzymać w pełni załadowane kostki do przechowywania dla dzieci.
29. Stosować wyłącznie zgodnie z przeznaczeniem.

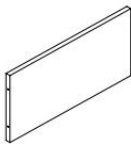
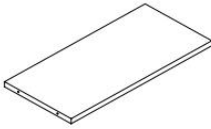
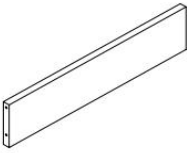
30. Przed każdym użyciem należy przeprowadzić kontrolę. Nie należy używać produktu, jeśli jakieś części są luźne lub uszkodzone.

ZAPISZ TĘ INSTRUKCJĘ

PARTS LIST

<p>①</p>  <p>X1</p>	<p>②</p>  <p>X1</p>	<p>③</p>  <p>X1</p>	<p>④</p>  <p>X1</p>				
<p>⑤</p>  <p>X1</p>	<p>⑥</p>  <p>X1</p>	<p>⑦</p>  <p>X4</p>	<p>⑧</p>  <p>X2</p>				
<p>⑨</p>  <p>X2</p>	<p>⑩</p>  <p>X2</p>						
<p>A</p> 	<p>5X35mm</p>	<p>X40</p>	<p>F</p>				<p>X1</p>
<p>B</p> 		<p>X1</p>					
<p>C</p> 		<p>X8</p>					
<p>D</p> 	<p>3.5X8mm</p>	<p>X16</p>					

ASSEMBLY STEP

1

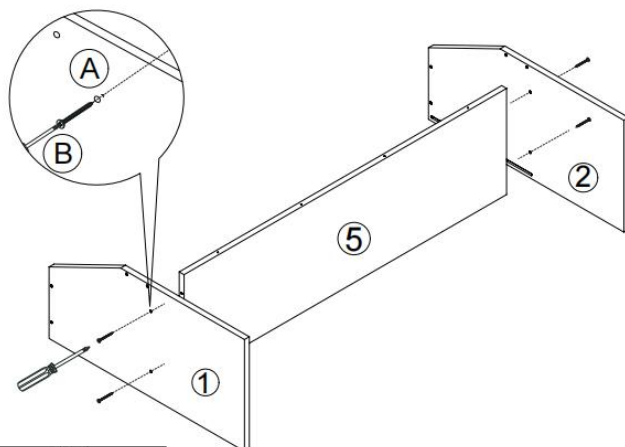

A		X4
B		X1

2

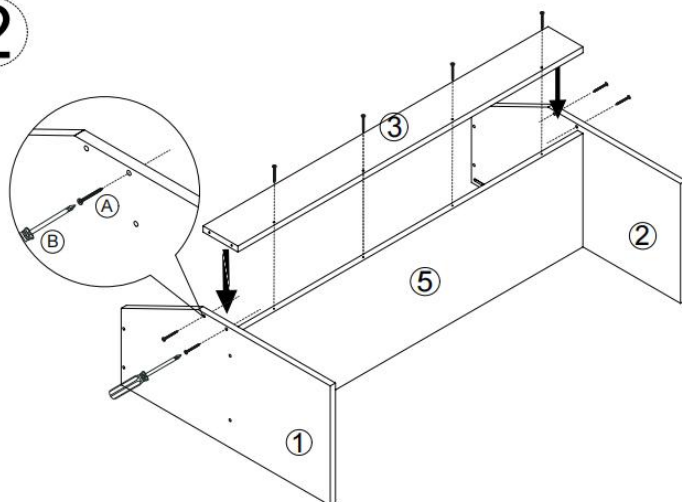

A		X8
B		X1

3

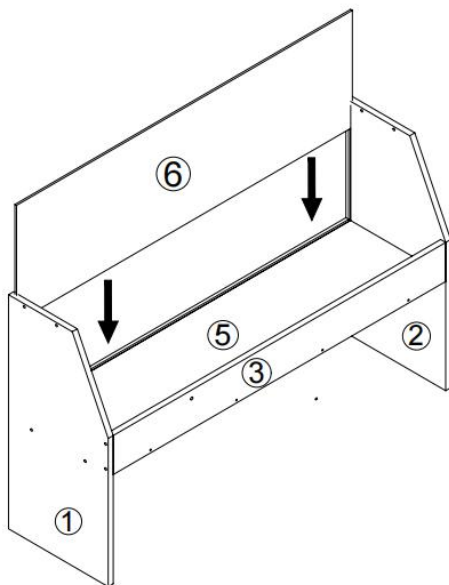

4

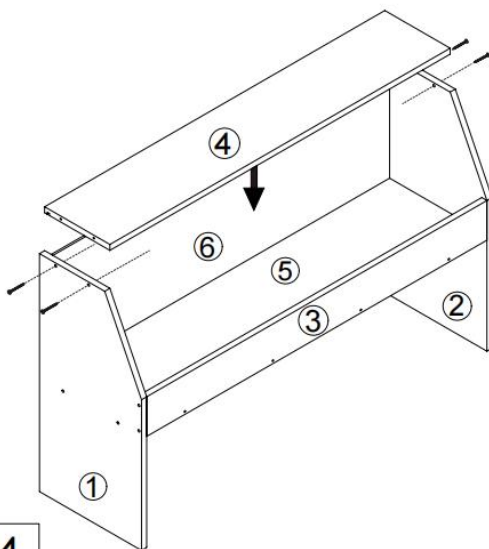

A		X4
B		X1

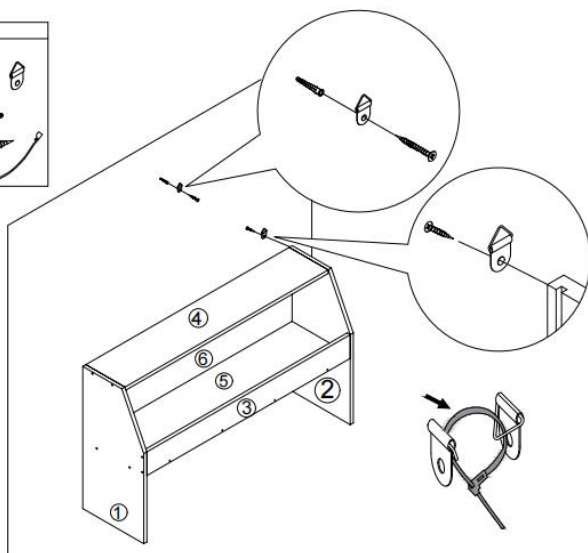
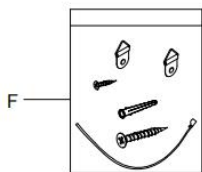
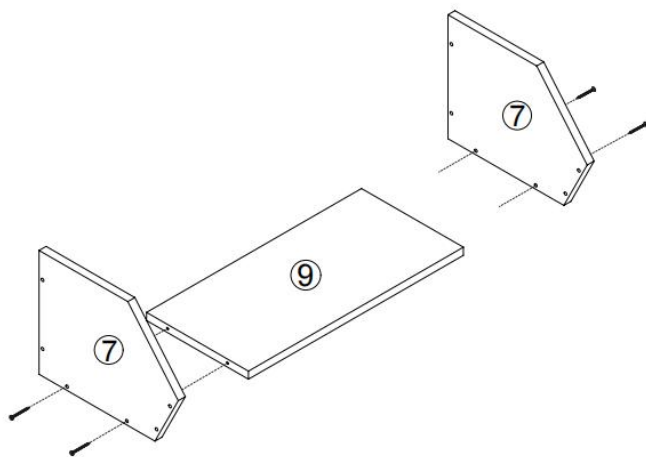
5**F****X1****6****A****X4****B****X1**

7

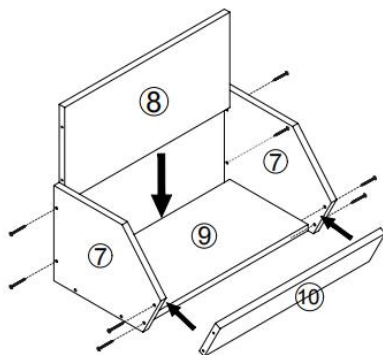

A		X8
B		X1

8

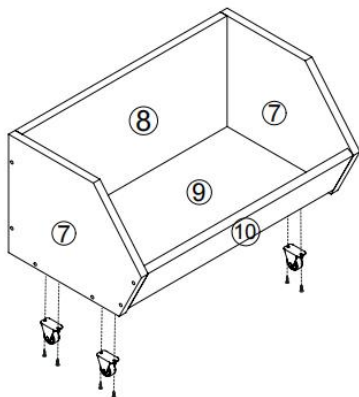

D		X8
B		X1

9

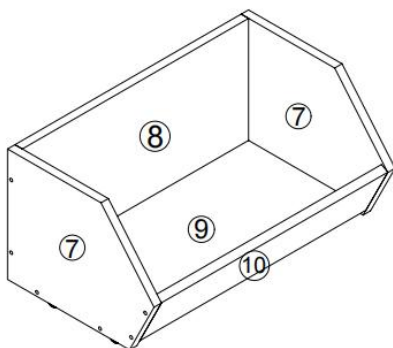

10

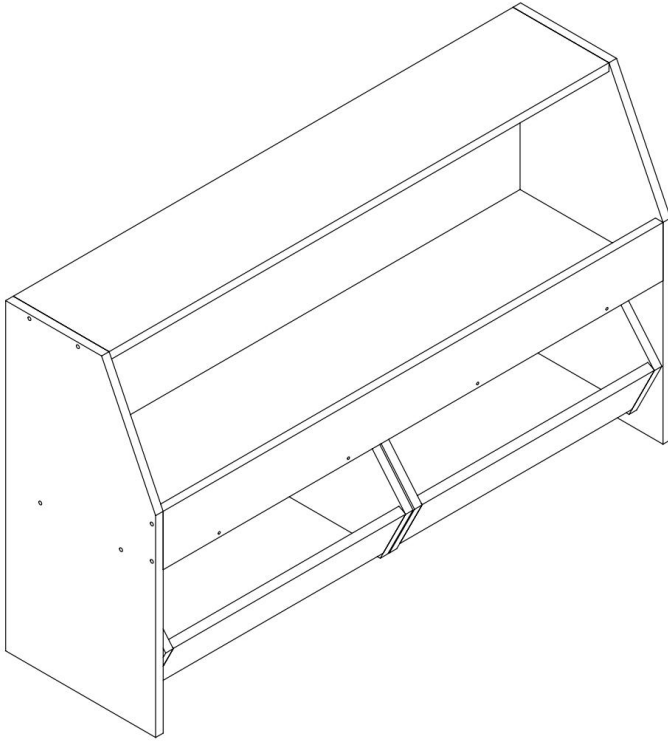

PRODUCT PARAMETER

Model	ZD-25A01
Liczba przegródek do przechowywania	3
Kolor	Biały
Rozmiar produktu	: 1020 * 297 * 600 mm

⚠ WARNING

	<p>Children have died from furniture tipover. To reduce the risk of furniture tipover:</p> <ul style="list-style-type: none">● ALWAYS install Anti-tip device provided.● NEVER put a TV on this product.● NEVER allow children to stand, climb or hang on drawers, doors, or shelves.● NEVER open more than one drawer at a time.● Place heaviest items in the lowest drawers.
	<p style="text-align: center;"><i>This is a permanent label. Do not remove!</i></p>

Producent: Shanghaimuxinmuyeyouxiangongsi

Adres: Shuangchenglu 803nong11hao1602A-1609shi, baoshanqu,
Szanghaj 200000 CN.

Importowane do AUS: SIHAO PTY LTD. 1 ROKEVA
STREETEASTWOOD

NSW 2122 Australia

Importowane do USA: Sanven Technology Ltd. Suite 250, 9166 Anaheim
Miejsce, Rancho Cucamonga, CA 91730

UK	REP
-----------	------------

YH CONSULTING LIMITED. C/O YH Consulting
Limited Office 147, Centurion House, London
Road, Staines-upon-Thames, Surrey, TW18 4AX

EC	REP
-----------	------------

E-CrossStu GmbH
Mainzer Landstr.69,
60329 Frankfurt am Main.



VEVOR

Affordable. Reliable. Home Improvement.





OPBERGKUBUSSEN VOOR KINDEREN

MODEL: ZD-25A01

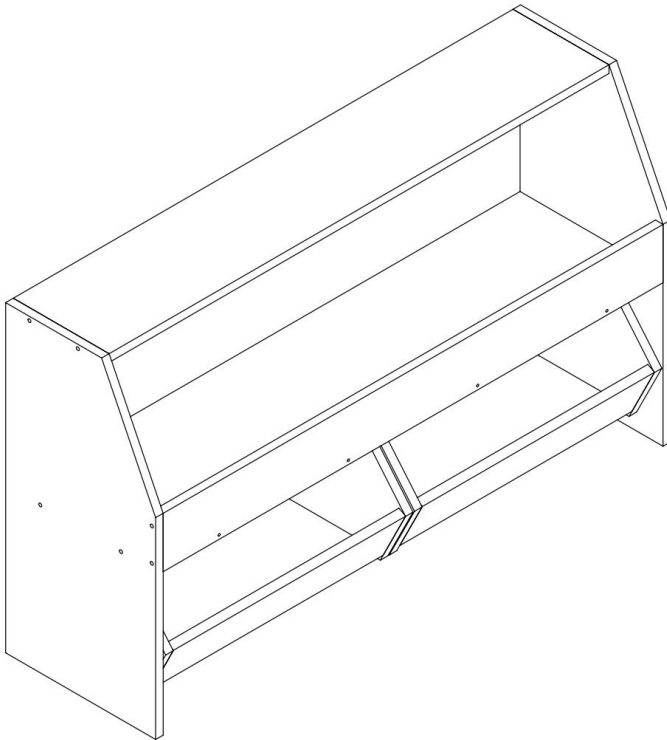
MODEL: ZD-25A01



Dit is de originele handleiding. Lees alle instructies zorgvuldig door voordat u het product gebruikt. VEVOR behoudt zich het recht voor om de gebruiksaanwijzing duidelijk te interpreteren. Het uiterlijk van het product is afhankelijk van het product dat u hebt ontvangen. Neemt u het ons niet kwalijk dat we u niet meer op de hoogte stellen van eventuele technologische of software-updates voor ons product.

	<p>Waarschuwing: om het risico op letsel te verminderen, moet de gebruiker de gebruiksaanwijzing zorgvuldig lezen .</p> <p>Let op: Montage door volwassenen vereist !</p>
	<p>Compliance is een C E- beveiligingscertificering.</p>
<p>Leeftijden</p>	<p>3 jaar +</p>

SAFETY INSTRUCTIONS

WAARSCHUWING:

Lees dit materiaal voordat u dit product gebruikt. Het niet naleven hiervan kan ernstig letsel tot gevolg hebben.

Vorzorgsmaatregelen voor montage

26. Monteer uitsluitend volgens deze instructies. Onjuiste montage kan gevaarlijk zijn.
27. Houd de verzamelplaats schoon en goed verlicht.
28. De producteigenschappen gelden uitsluitend voor volledig en correct gemonteerde producten.
29. Monteer de set op een vlak, egaal, hard en glad oppervlak dat de Kids Storage Cubes veilig kan dragen.
30. Raadpleeg voor meer informatie over de onderdelen die op de volgende pagina's worden vermeld het montageschema in deze handleiding. Pak alle onderdelen uit en scheid ze van elkaar op een schone werkplek.











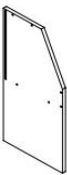

Gebruik voorzorgsmaatregelen

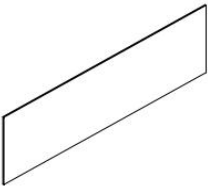
31. NIET OP DIT ONDERDEEL ZITTEN OF STAAN.
32. Dit product is geen speelgoed. Laat kinderen niet met of in de buurt van dit artikel spelen.
33. Niet overschrijden aangegeven gewichtscapaciteiten.
34. Gebruik de Kids Storage Cubes alleen op een vlak, egaal, hard en glad oppervlak dat een volledig gevulde Kids Storage Cubes veilig kan dragen.
35. Alleen gebruiken zoals bedoeld.
36. Controleer het product voor elk gebruik. Niet gebruiken als er

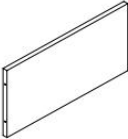
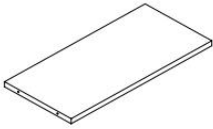
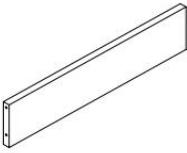
onderdelen loszitten of beschadigd zijn.

BEWAAR DEZE HANDLEIDING

PARTS LIST

<p>①</p>  <p>X1</p>	<p>②</p>  <p>X1</p>	<p>③</p>  <p>X1</p>	<p>④</p>  <p>X1</p>				
<p>⑤</p>  <p>X1</p>	<p>⑥</p>  <p>X1</p>	<p>⑦</p>  <p>X4</p>	<p>⑧</p>  <p>X2</p>				
<p>⑨</p>  <p>X2</p>	<p>⑩</p>  <p>X2</p>						
<p>A</p> 	<p>5X35mm</p>	<p>X40</p>	<p>F</p>				<p>X1</p>
<p>B</p> 		<p>X1</p>					
<p>C</p> 		<p>X8</p>					
<p>D</p> 	<p>3.5X8mm</p>	<p>X16</p>					

ASSEMBLY STEP

1

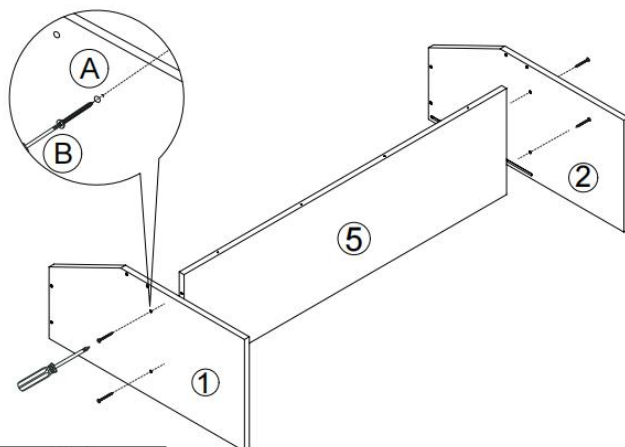

A		X4
B		X1

2

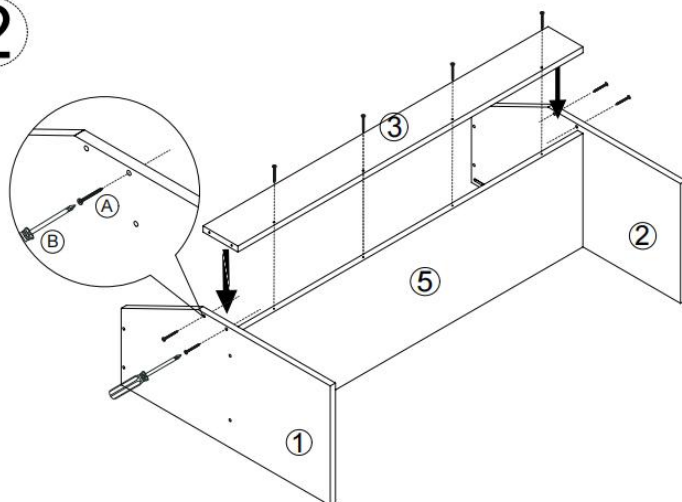

A		X8
B		X1

3

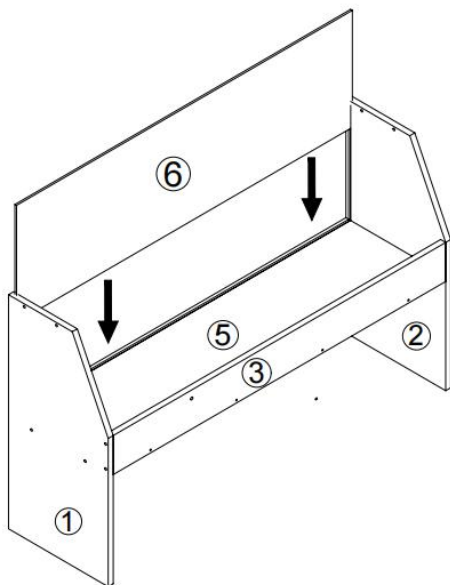

4

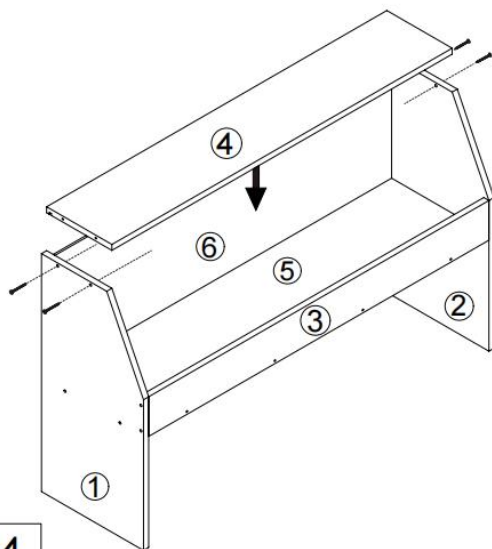

A		X4
B		X1

5

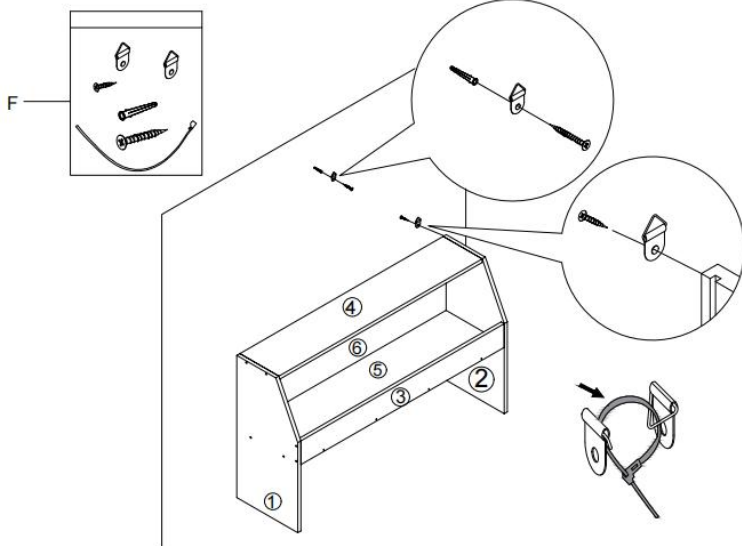

F



X1

6

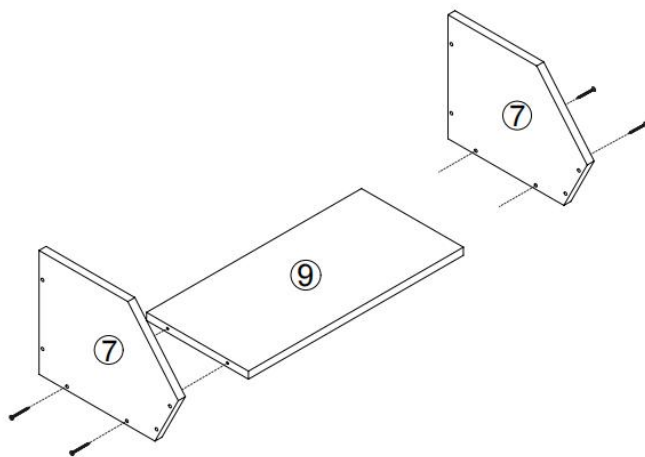

A



X4

B



X1

7

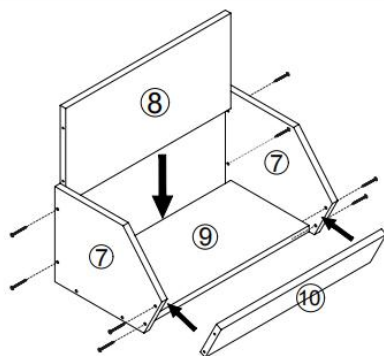

A		X8
B		X1

8

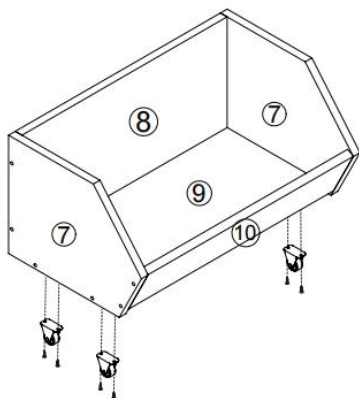

D		X8
B		X1

9

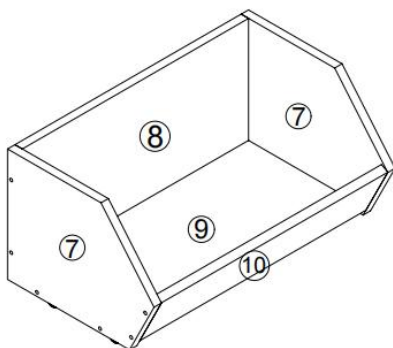

10

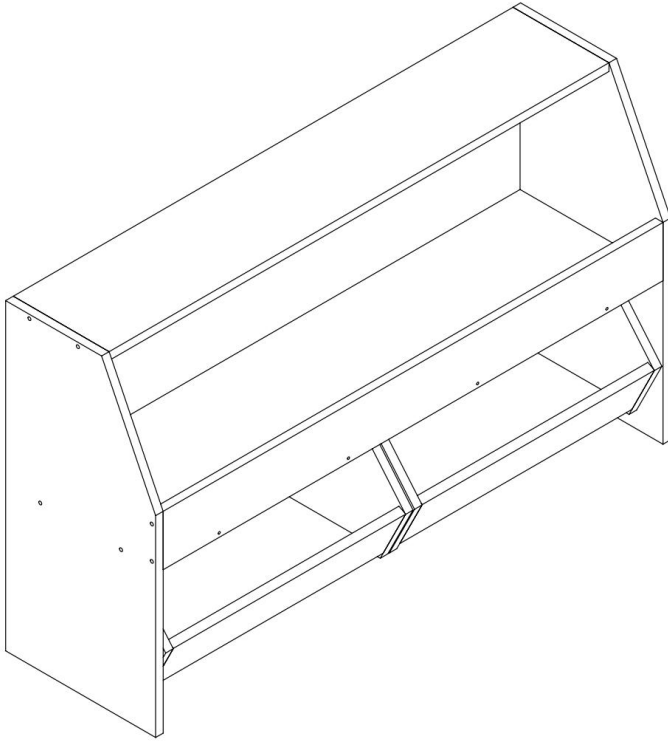

PRODUCT PARAMETER

Model	ZD-25A01
Aantal opbergvakken	3
Kleur	Wit
Productgrootte	1020 * 297 * 600 mm

⚠ WARNING



Children have died from furniture tipover. To reduce the risk of furniture tipover:

- ALWAYS install Anti-tip device provided.
- NEVER put a TV on this product.
- NEVER allow children to stand, climb or hang on drawers, doors, or shelves.
- NEVER open more than one drawer at a time.
- Place heaviest items in the lowest drawers.

***This is a permanent label.
Do not remove!***

Fabrikant: Shanghaimuxinmuyeyouxiangongsi

Adres: Shuangchenglu 803nong11hao1602A-1609shi, baoshanqu, shanghai 200000 CN.

Geïmporteerd naar AUS: SIHAO PTY LTD. 1 ROKEVA STREETEASTWOOD

NSW 2122 Australië

Geïmporteerd naar de VS: Sanven Technology Ltd. Suite 250, 9166 Anaheim

Plaats, Rancho Cucamonga, CA 91730

UK	REP
-----------	------------

YH CONSULTING LIMITED. C/O YH Consulting Limited Office 147, Centurion House, London Road, Staines-upon-Thames, Surrey, TW18 4AX

EC	REP
-----------	------------

E-CrossStu GmbH
Mainzer Landstr.69,
60329 Frankfurt am Main.



VEVOR

Affordable. Reliable. Home Improvement.





FÖRVARINGSKUBER FÖR BARN

MODELL: ZD-25A01

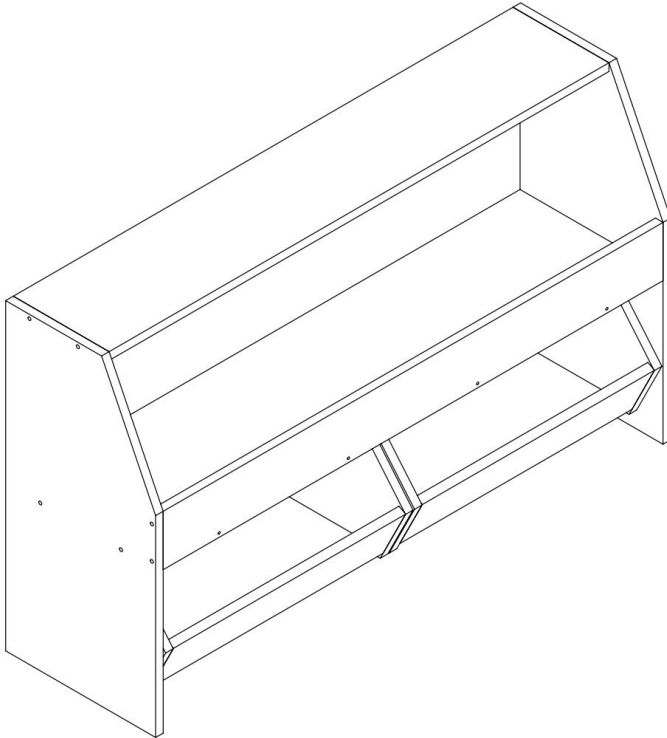
MODELL: ZD-25A01



Detta är originalinstruktionerna, vänligen läs alla instruktioner noggrant innan du använder produkten. VEVOR förbehåller sig en tydlig tolkning av vår användarmanual. Produktens utseende ska vara beroende av den produkt du mottagit. Vi ber om ursäkt för att vi inte kommer att informera dig igen om det finns några teknik- eller programuppdateringar för vår produkt.

	<p>Varning – För att minska risken för skador måste användaren läsa instruktionsmanualen noggrant .</p> <p>Obs: Montering krävs av vuxna !</p>
	<p>Efterlevnad är en CE- säkerhetscertifiering .</p>
<p>Åldrar</p>	<p>3 år +</p>

SAFETY INSTRUCTIONS

WARNING:

Läs detta material innan du använder produkten. Underlåtenhet att göra det kan leda till allvarliga skador.

Monteringsförsiktighetsåtgärder











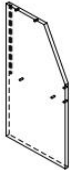
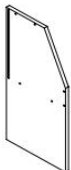

31. Montera endast enligt dessa instruktioner. Felaktig montering kan orsaka risker.
32. Håll samlingsområdet rent och väl upplyst.
33. Produktens egenskaper gäller endast korrekt och fullständigt monterade produkter.
34. Montera på en plan, jämn, hård och slät yta som säkert kan bära förvaringskuberna för barn.
35. För ytterligare information om delarna som listas på följande sidor, se monteringsdiagrammet i denna manual. Packa upp och separera alla delar på en ren arbetsyta.

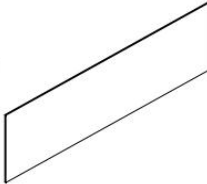
Använd försiktighetsåtgärder

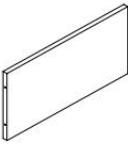
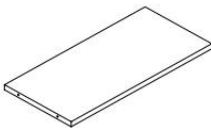
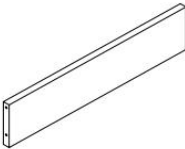
37. SITTA ELLER STÅ INTE PÅ DENNA FÖRENING.
38. Denna produkt är inte en leksak. Låt inte barn leka med eller i närheten av denna produkt.
39. Överskrid inte angivna viktkapacitet.
40. Använd endast på en plan, jämn, hård och slät yta som säkert kan bära en fulladdad förvaringskub för barn.
41. Använd endast som avsett.
42. Kontrollera före varje användning; använd inte om delar är lösa eller skadade.

SPARA DENNA HANDBOK

PARTS LIST

①		X1					
②		X1					
③		X1					
④		X1					
⑤		X1					
⑥		X1					
⑦		X4					
⑧		X2					
⑨		X2					
⑩		X2					
A		5X35mm	X40	F			X1
B			X1				
C			X8				
D		3.5X8mm	X16				

ASSEMBLY STEP

1

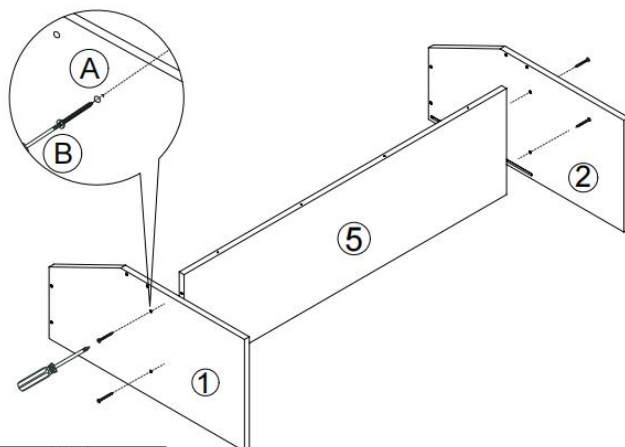

A		X4
B		X1

2

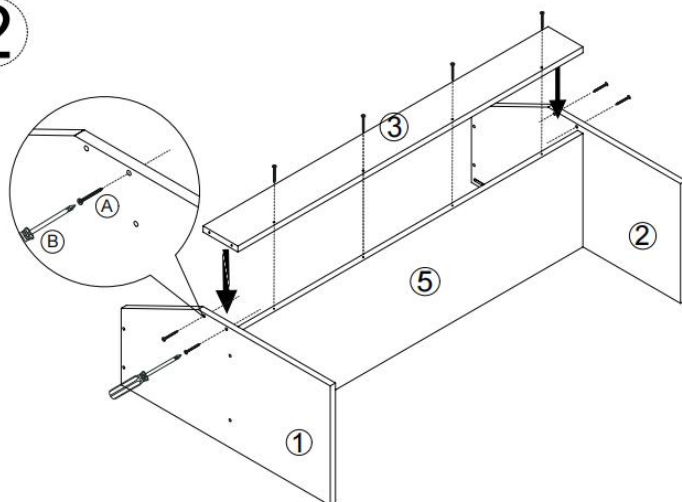

A		X8
B		X1

3

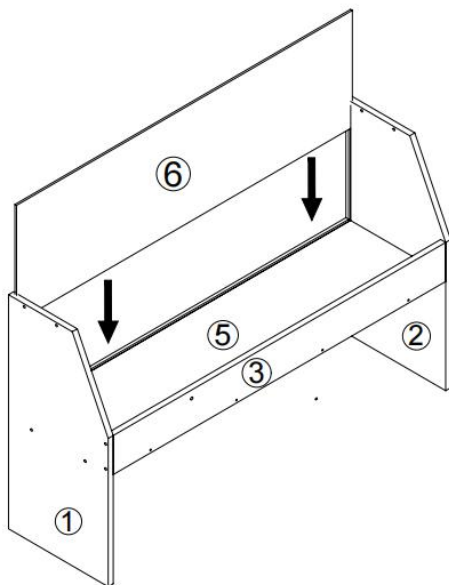

4

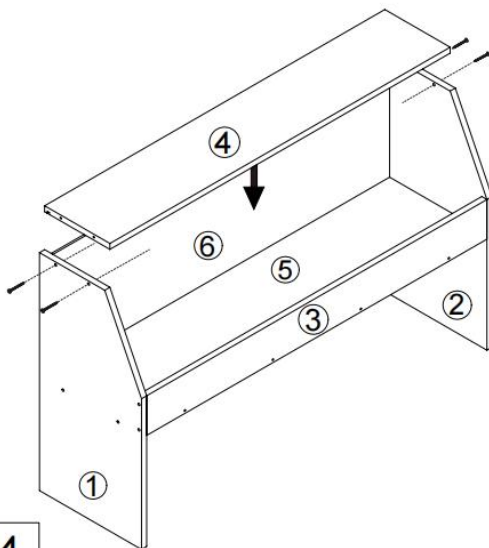

A		X4
B		X1

5

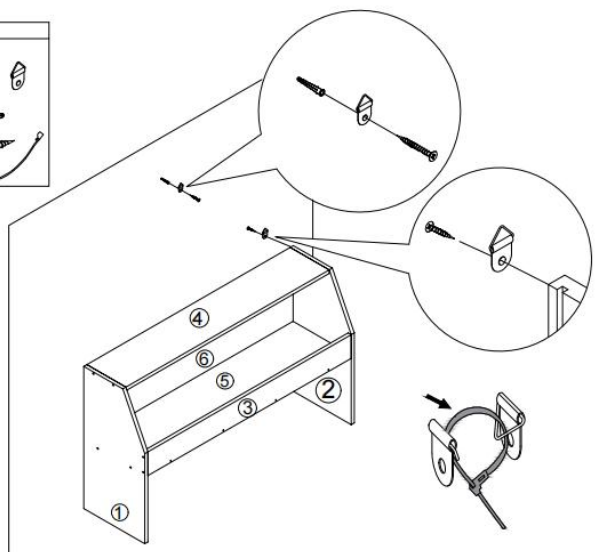
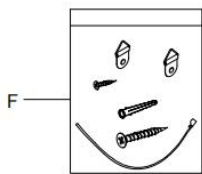

F



X1

6

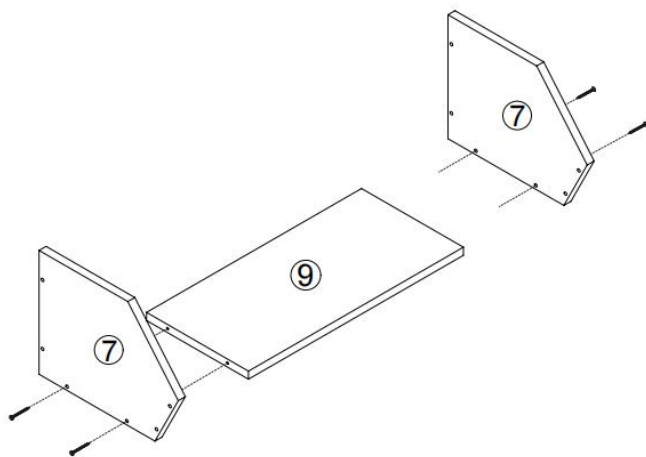

A



X4

B



X1

7

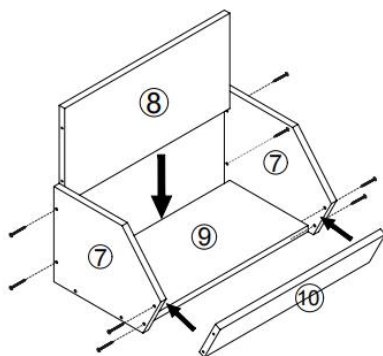

A		X8
B		X1

8

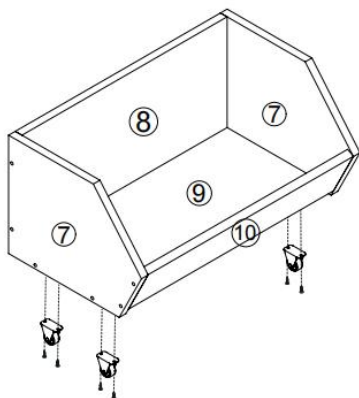

D		X8
B		X1

9

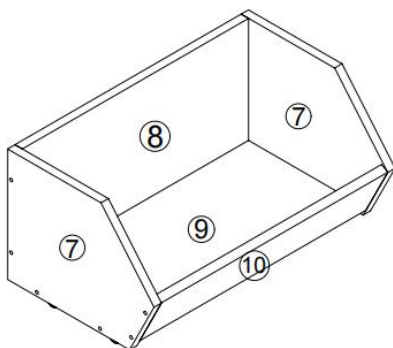

10

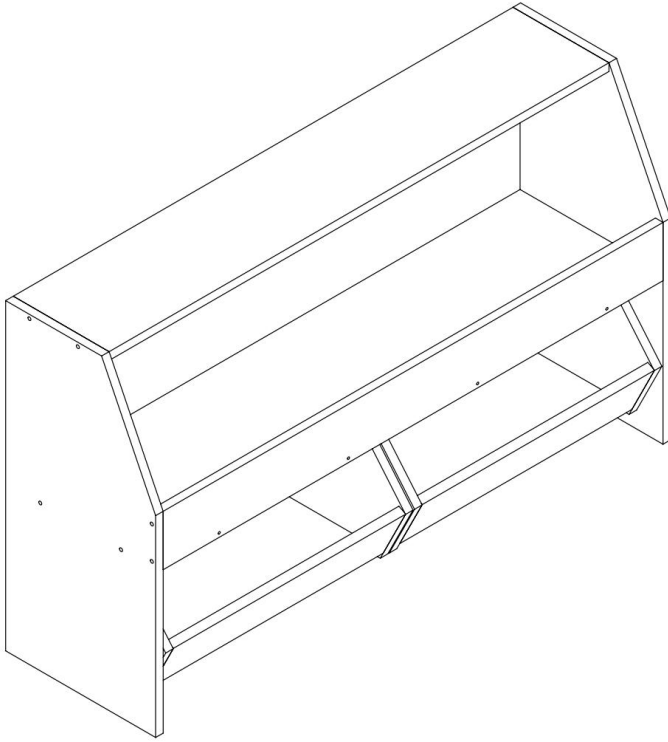

PRODUCT PARAMETER

Modell	ZD-25A01
Antal förvaringsfack	3
Färg	Vit
Produktstorlek	1020 * 297 * 600 mm

⚠ WARNING



Children have died from furniture tipover. To reduce the risk of furniture tipover:

- ALWAYS install Anti-tip device provided.
- NEVER put a TV on this product.
- NEVER allow children to stand, climb or hang on drawers, doors, or shelves.
- NEVER open more than one drawer at a time.
- Place heaviest items in the lowest drawers.

***This is a permanent label.
Do not remove!***

Tillverkare: Shanghaimuxinmuyeyouxiangongsi

Adress: Shuangchenglu 803nong11hao1602A-1609shi, baoshanqu,
Shanghai 200 000 kanadensiska republiken.

Importerad till Australien: SIHAO PTY LTD. 1 ROKEVA
STREETEASTWOOD

NSW 2122 Australien

Importerad till USA: Sanven Technology Ltd. Suite 250, 9166 Anaheim
Plats, Rancho Cucamonga, Kalifornien 91730

UK	REP
-----------	------------

YH CONSULTING LIMITED. C/O YH Consulting
Limited Office 147, Centurion House, London
Road, Staines-upon-Thames, Surrey, TW18 4AX

EC	REP
-----------	------------

E-CrossStu GmbH
Mainzer Landstr.69,
60329 Frankfurt am Main.

