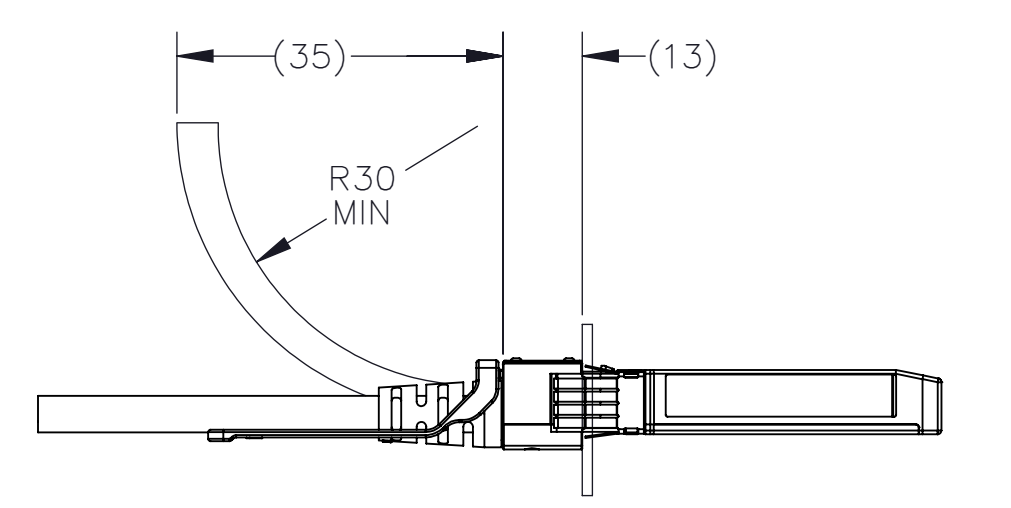
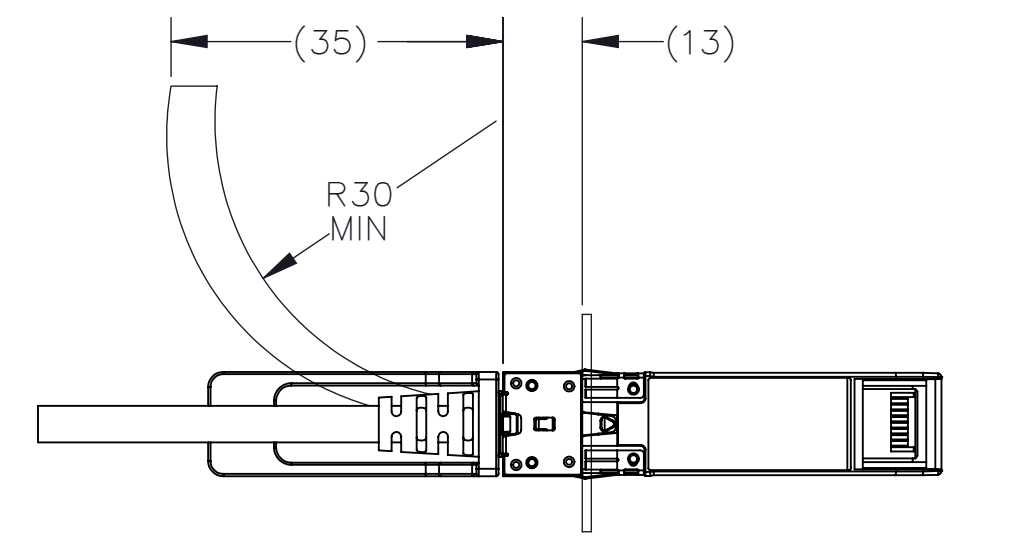
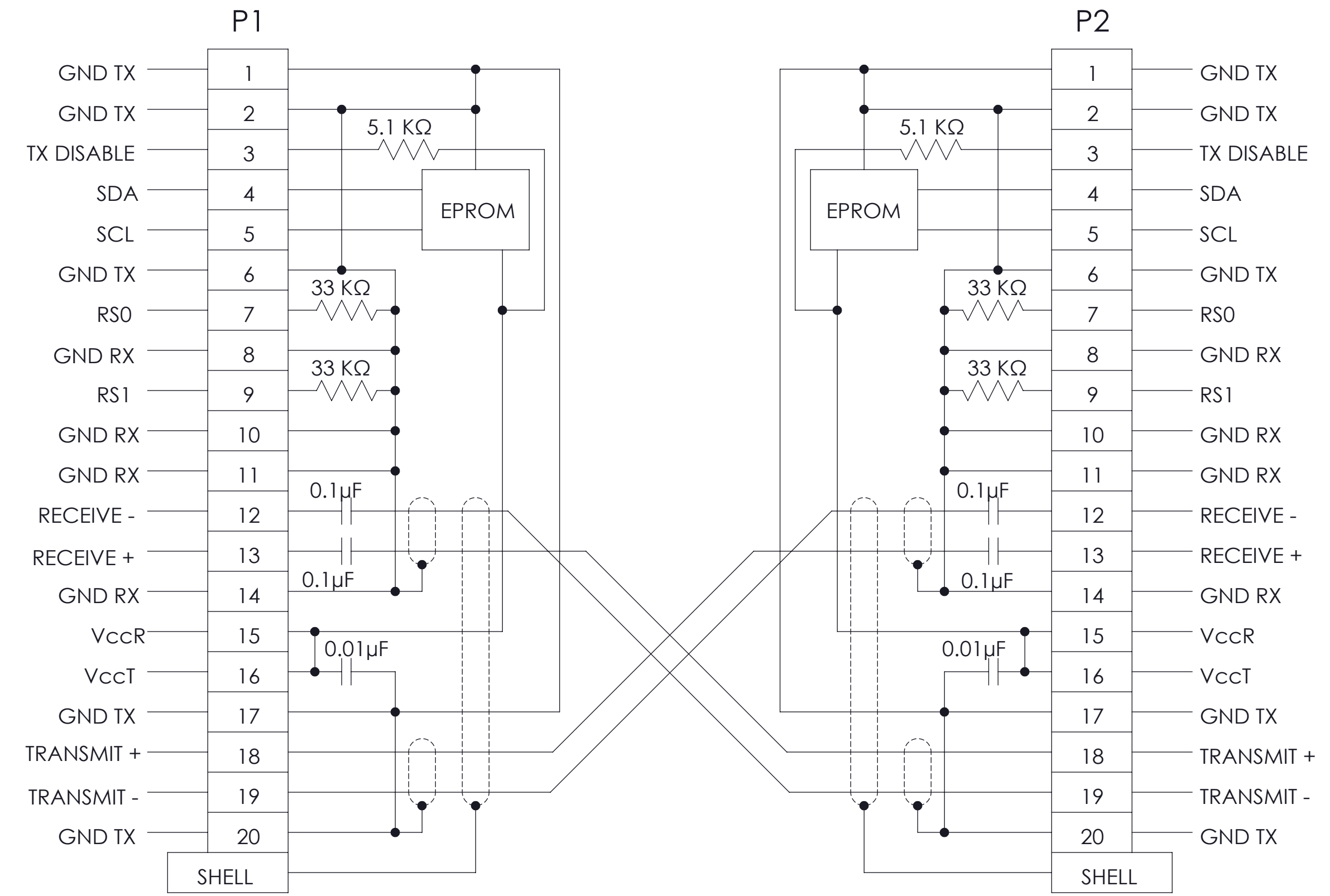
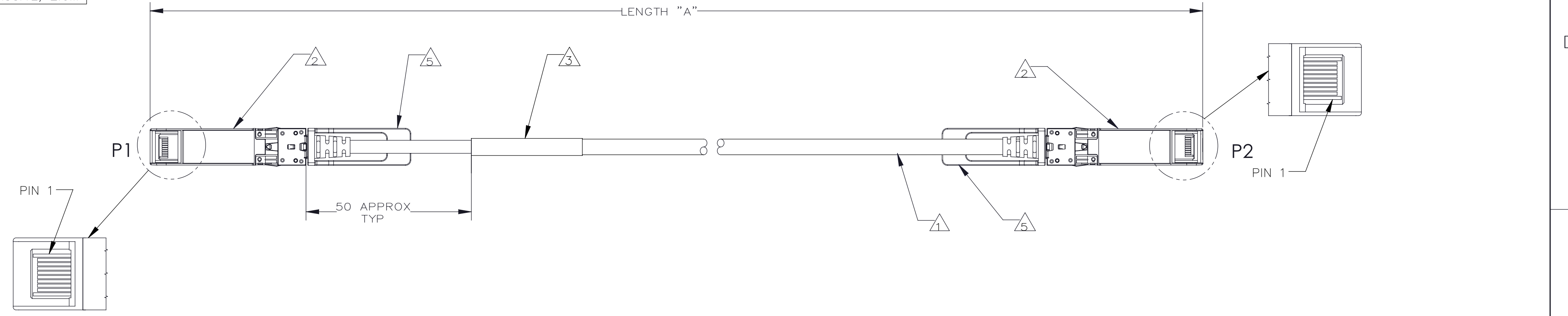

TABLE 1			
AHSP P/N	LENGTH "A"	CUSTOMER P/N	DESCRIPTION
NDCCGF-C101	1000 ±25	SF-NDCCGF28GB-001M	SFP+/SFP+ 30AWG PASSIVE, 1M
NDCCGF-C102	2000 ±50	SF-NDCCGF28GB-002M	SFP+/SFP+ 30AWG PASSIVE, 2M
NDCCGF-C103	3000 ±75	SF-NDCCGF28GB-003M	SFP+/SFP+ 30AWG PASSIVE, 3M
NDCCGF-C104	500 ±12	SF-NDCCGF28GB-000.5M	SFP+/SFP+ 30AWG PASSIVE, 0.5M
NDCCGF-C105	1500 ±38	SF-NDCCGF28GB-001.5M	SFP+/SFP+ 30AWG PASSIVE, 1.5M
NDCCGF-C106	2500±60	SF-NDCCGF28GB-002.5M	SFP+/SFP+ 30AWG PASSIVE, 2.5M

REVISIONS						
ZONE	REV.	ECN NUMBER	DESCRIPTION	BY	DATE	APPROVED
	F	BZHU-20042101	ADD REF VALUE	R.LI	04/29/2020	W.ZHANG
	G	RGAO-21020307	ADDED DESCRIPTION COLUMN TO TABLE 1.	N.ZENG	2/4/2021	A.LI
	H	ALII-21042002	ADDED -C106 IN TABLE 1, DELETED CE LABEL & (1) LABEL WRAPPED IN VIEWS, DELETED NOTES #5.	R.LI	04/16/2021	J.CHN

NOTE: ONLY THREE MOST RECENT RELEASED REVISIONS DISPLAYED.

TABLE 2	
ITEM No.	DESCRIPTION
1	30 AWG EXD, 2-PR., PVC BLACK, AWM STYLE 20276 80°C VW-1
2	PLUG, SFP+, REFERENCE SFF-8432, PULL TO RELEASE
3	LABEL, WRAPPED - AHSP P/N, REV, DATE CODE, LENGTH, CoO, & SERIAL NUMBER
5	LANYARD, GREEN



BEND DISTANCE FROM EDGE OF DIECAST

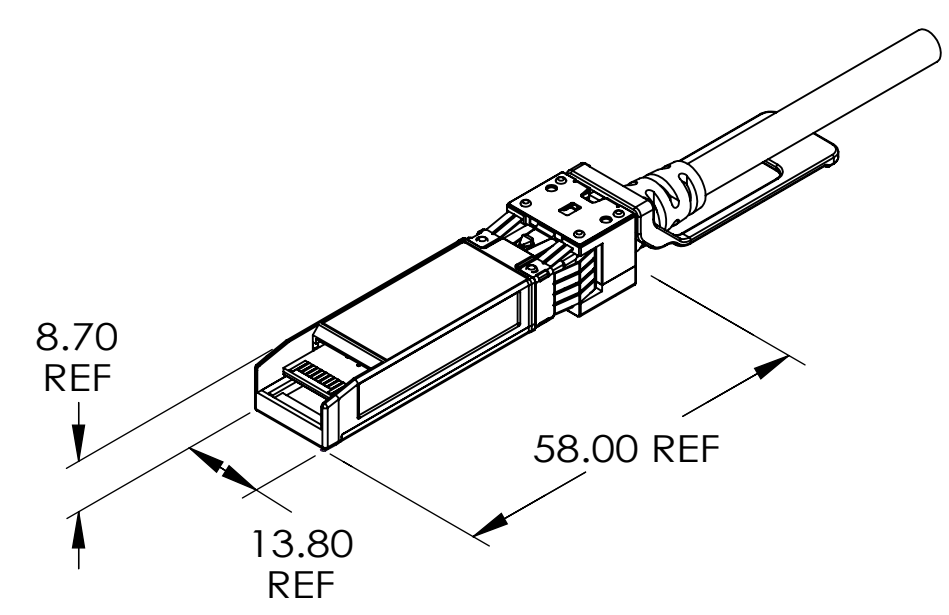

SFP+ DIECAST DIMENSIONS

- UL LABEL MUST BE ON SHIPPING CARTON PER SUBJECT 764 OF THE UL COMPONENT WIRING HARNESS (ZPFW2) FILE #E86140. CSA LABEL MUST BE ON SHIPPING CARTON.
 - PACKAGE COMPLETED ASSY IN AN APPROPRIATELY SIZED ESD BAG.
 - EPROM CONTENT SHALL BE COMPLIANT WITH SFF-8472 SPECIFICATION. EPROM REVISION IS EQUAL TO AHSP PART NUMBER REVISION UNLESS OTHERWISE NOTED.
 - CABLE ASSEMBLIES MUST MEET SHIELDING EFFECTIVENESS REQUIREMENTS OF 35dB MINIMUM FROM 1-10GHz AND 30dB FROM 10-18 GHz.
 - CABLE ASSEMBLIES, COMPONENTS AND SUB-COMPONENTS SHALL BE COMPLIANT TO EU DIRECTIVE 2011/65/EU-RoHS2.
 - ASSEMBLIES SHALL BE COMPLIANT TO SFF-8431 (APPENDIX E) SPECIFICATION.
 - THIS DRAWING IS RESERVED FOR AMPHENOL CABLES ON DEMAND.
- NOTES: UNLESS OTHERWISE SPECIFIED

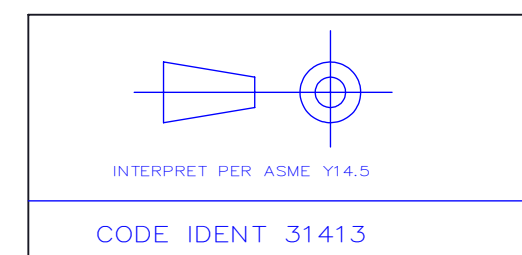

TOLERANCES	DWN 10/12/2015	DC	Amphenol AHSP A Division of Amphenol Corporation 200 Innovative Way, Suite 201, Nashua, NH 03062 (603) 879-3000
0.0 ± 0.25	CHK 10/12/2015	DD	
0.00 ± 0.08	APVD 10/12/2015	EM	
0.000 ± -			
ANGLES ± 1.0°			
UNLESS OTHERWISE SPECIFIED DIMENSIONS ARE IN MM			TITLE CABLE ASSEMBLY, SFP+/SFP+, 28Gbps, PASSIVE, 1000, 30 AWG EXD
PART NO.		SEE TABLE 1	REV N/A
DRAWING NO.		C-NDCCGF-C199	REV H
SIZE D	SCALE 1:1	SHEET 1 of 1	

CUSTOMER USE DRAWING