



TEST REPORT
EN 15194:2017+A1:2023
Cycles - Electrically power assisted cycles - EPAC Bicycles

Report Reference No.....: STL2024S0923223C-Y1R01

Tested by (name and signature).....: Sunny

Approved by (name and signature): Barry

Date of issue.....: Sep .23,2024

Total number of pages.....: 48 pages



Testing Laboratory.....: Shenzhen STL Testing Technology Co., Ltd.

Address.....: Unit C, 4F, Building A, ShengHengji Industrial Park, No. 137 FuYuan 1 Road, Heping Community, Fuyong Street, Baoan District, Shenzhen, China

Testing location.....: Same as above

Applicant's name.....: QINGYUAN HAORUND TECHNOLOGY CO.,LTD.

Address.....: Floor 3, Building 2, No.2, Huangpu 3rd Road, Guangqing Industrial Park, Shijiao Town, Qingcheng District, Qingyuan City, Guangdong Province

Test specification:

Standard.....: EN 15194:2017+A1:2023

Test procedure.....: N/A

Non-standard test method.....: N/A

Test Report Form No.....: EN 15194

Test Report Form(s) Originator.....: STL

Master TRF.....: Dated 2017-03

This test report is specially limited to the above client company and product model only. It may not be duplicated without prior written consent of STL Test.

Test item description.....: Electric bicycle

Trade Mark.....: TT GO

Manufacturer.....: Sencycle Europe sp. z o. o.

Address.....: ul. Magazynowa 1,55-040 Bielany Wrocławskie, Poland

Model/Type reference.....: HZ-28ST

Ratings.....: Power Adapter:Input:100-240V~,50/60Hz,2.A Max

Output:42.0V ---3.0A 126W

Battery capacity: 36V--- 20Ah,720Wh



Possible test case verdicts:	
- test case does not apply to the test object.....:	N/A
- test object does meet the requirement.....:	P (Pass)
- test object does not meet the requirement.....:	F (Fail)

Testing.....:	
Date of receipt of test item.....:	Sep .16,2024
Date (s) of performance of tests.....:	Sep .16-23,2024

General remarks:	List of Attachments :
<p>"(see remark #)" refers to a remark appended to the report.</p> <p>"(see appended table)" refers to a table appended to the report.</p> <p>Throughout this report a comma is used as the decimal separator.</p> <p>The test results presented in this report relate only to the object tested.</p> <p>This report shall not be reproduced except in full without the written approval of the testing laboratory.</p> <p>When determining the test conclusion, the Measurement Uncertainty of test has been considered.</p> <p>Unless otherwise specified, test are made under normal conditions at an ambient temperature within the range of 15°C to 35°C, RH45% to 75% and an air pressure of 860mbar of 1060mbar</p>	<p>-Appendix 1: Photo document. (4 pages)</p>

EN 15194

Clause	Requirement	Test	Result – Remark	Verdict
4	Safety requirements and/or protective measures			-
4.1	General			-
	EPAC shall be designed according to the principles of EN ISO 12100 for relevant but not significant hazards, which are not dealt with by this document. It includes evaluation of such risks for all relevant components. Means shall be provided to the user to prevent an unauthorized use of the EPAC e.g. key, locks, electronic control device.			P
4.2	Electrical requirements			-
4.2.1	Electric circuit			-
	The electrical control system shall be designed so that, should it malfunction in a hazardous manner, it shall switch off power to the electric motor without causing a hazardous situation and it requires user interaction to switch on again. NOTE The mechanical brakes serve as an emergency stop device and provide fast and safe stopping in emergency situations.			P
4.2.2	Controls and symbols			-
	If symbols are used, their meaning shall be described in the instructions for use. “On” “Off” symbols, lightings symbols, start-up assistance symbols, audible warning device symbols design shall be in accordance with those described in Annex I and Annex J. A master control device shall be fitted to switch on and shut off the assistance, which shall be apparent, easy to reach and unmistakable. This master control device shall be activated by voluntary action to enable all assistance modes (start up and pedalling) before use of the EPAC.			P

EN 15194				
Clause	Requirement	Test	Result – Remark	Verdict
4.2.3	Batteries			-
4.2.3.1	Requirements			-
	a) The EPAC and batteries pack shall be designed in order to avoid risk of fire and mechanical deterioration resulting from abnormal use. Compliance is checked by the test described in 4.2.3.2. b) During the test the EPAC and the batteries shall not emit flames, molten metal or poisonous ignitable gas in hazardous amounts and any enclosure shall show no damage that could impair compliance with this European Standard. Safety and compatibility of the battery/charger combination shall be ensured, according to the manufacturer's specifications. c) The battery terminals shall be protected against creating an accidental short circuit. d) An appropriate care shall be taken to ensure that the batteries are protected against overcharging. An appropriate overheating and short circuit protection device shall be fitted.			P
4.2.4	Battery charger			-
	Chargers for EPAC are considered to be operated in a residential (household) environment. NOTE 1 For integrated battery charger with a 230V a.c. input the charger and the EPAC and for external battery charger supplied with an EPAC the requirements of the Low Voltage Directive are applicable.		Approved Li-ion Battery Charger Used	P
4.2.5	Electric cables and connections			-
4.2.5.1	General			-
	All connectors for cable and wire shall be selected to prevent corrosion of electrical contact conductance.			P
4.2.5.2	Requirements			-
	Cable and plug temperature shall be lower than that specified by the manufacturer of the cables and plugs. Damage to cable and plug insulation shall be prevented. The cable cross sections shall be selected in accordance to EN 60335-1:2012, Table 11. If these requirements are not met, a temperature rise test shall be performed, in accordance to 4.2.5.3. NOTE Cables used exclusively for communication lines are excluded.			P
4.2.6	Wiring			-
	Requirements on wiring shall be checked according to the following sequence at an ambient room temperature (20 ± 5) °C.			P

EN 15194				
Clause	Requirement	Test	Result – Remark	Verdict
	<p>a) Wire ways shall be smooth and free from sharp edges.</p> <p>b) Wires shall be protected so that they do not come into contact with burrs, cooling fins or similar sharp edges that may cause damage to their insulation. Holes in metal through which insulated wires pass shall have smooth well-rounded surfaces or be provided with bushings.</p> <p>c) Wiring shall be effectively prevented from coming into contact with moving parts. Compliance with a), b), c) shall be checked by inspection.</p> <p>d) Separate parts of the EPAC that can move in normal use or during user maintenance relative to each other, shall not cause undue stress to electrical connections and internal conductors, including those providing ground continuity.</p> <p>If an open coil spring is used to protect wire, it shall be correctly installed and insulated. Flexible metallic tubes shall not cause damage to the insulation of the conductors contained within them. Compliance with d) shall be checked by inspection and by the following test method.</p> <p>If flexing occurs in normal use, the appliance is placed in its normal operational position and is supplied at rated voltage under normal operation.</p> <p>The movable part is moved backwards and forwards through the largest angle permitted by its construction, so that the conductor is flexed.</p> <p>For conductors that are flexed in normal use, flex movable part for 10 000 cycles at a test frequency of 0,5 Hz.</p> <p>For conductors that are flexed during user maintenance, flex the movable part for 100 cycles at the same frequency.</p>			
4.2.7	Power cables and conduits			-
	<p>Conduit entries, cable entries and knockouts shall be constructed or located so that the introduction of the conduit or cable does not reduce the protection measures adopted by the manufacturer.</p> <p>Compliance is checked by inspection. Guidance for power cables size selection is given in HD 60364-5-52:2011, 5.22.1.2, 523.1523.3 and Table A. The insulation of internal wiring shall withstand the electrical stress likely to occur in normal use. The wiring and its connections shall withstand the electrical strength test. The test voltage expressed in V shall be equal to $1.5 \times U_r$ for 2 min and applied between live parts and other metal parts only.</p> <p>NOTE U_r is the rated voltage.</p>			P
4.2.8	External and internal electrical connections			-

EN 15194				
Clause	Requirement	Test	Result – Remark	Verdict
	Electrical connection shall comply with HD 60364-5-52:2011, 526.1 and 526.2.			P
4.2.9	Moisture resistance			-
	The electrical components of a fully assembled EPAC shall be tested and shall comply with IPX4 requirements according to EN 60529:1991.			P
4.2.10	Mechanical strength test			-
	<p>The electrical components including the battery shall have adequate mechanical strength and be constructed to withstand such rough handling that may be expected in normal use. Compliance is checked by:</p> <p>— Applying impacts to the battery pack mounted on the EPAC by means of the spring hammer as specified in EN 60068-2-75. The battery pack is rigidly supported and three impacts are applied to every point of the enclosure that is likely to be weak with an impact energy of $(0,7 \pm 0,05)$ J. After the test the battery pack shall show no damage that could impair compliance with this European Standard;</p> <p>— Detachable batteries are submitted to free fall on a rigid surface as specified in EN 22248 at a height of 0,90 m in three different positions. The positions shall be one surface, one edge and one corner of the enclosure that is likely to be weak. After the test the battery pack shall show no damage that could lead to emission of dangerous substances (gas or liquid) ignition, fire or overheating.</p> <p>NOTE 1 Other standards and transportation regulation given in national and international regulations, give additional requirements for general design of the battery and battery pack.</p> <p>NOTE 2 It is advised that the bicycle manufacturer make a risk analysis for the battery and battery holder interface with regard to bicycle tip over. It may be possible for damage to occur to the battery or battery interface when the bicycle falls over (see also the Introduction).</p>			P
4.2.11	Maximum speed for which the electric motor gives assistance			-
4.2.11.1	Requirements			-
	<p>The electrical motor assistance shall stop when the EPAC reaches a speed of 25 km/h or lower speed if limited by design.</p> <p>The maximum speed of the EPAC for which the electric motor gives assistance shall not differ by more than +10 % from the maximum assistance speed indicated in the marking required by Clause 5 when determined according to the test method described in 4.2.11.2.</p>			P
4.2.12	Start-up assistance mode			-

EN 15194				
Clause	Requirement	Test	Result – Remark	Verdict
4.2.12.1	Requirements			-
	<p>An EPAC can be equipped with a start-up assistance mode that operates up to a maximum speed of 6 km/h.</p> <p>This mode shall be activated by the voluntary and maintained action of the user either when riding without pedalling or when the user is pushing the cycle.</p>			P
4.2.13	Power management			-
4.2.13.1	Requirements			-
	<p>a) When tested by the method described in 4.2.13.2 the recordings shall show that assistance shall be provided only when the cyclist pedals forward. This requirement shall be checked according to the test methods described in 4.2.13.2.3;</p> <p>b) assistance shall be cut off when the cyclist stops pedalling forward and the cut-off distance shall not exceed 2 m;</p>			P
	<p>c) If all braking devices (e.g. levers, back pedal) are equipped with cut-off switches, the cut off distance shall not exceed 5 m;</p> <p>d) the power output or assistance shall be progressively reduced (see Annex B) and finally cut off as the EPAC reaches the maximum assistance speed as designed. This requirement shall be checked according to the test methods described in 4.2.13.2;</p> <p>e) the assistance shall be progressively and smoothly managed (e.g. no hunting);</p> <p>f) two independent applying actions shall be required to start the electrical assistance mode (e.g. power switch and forward pedalling activation); a traffic caused stop (e.g. traffic lights) is not subject to this requirement;</p> <p>g) after a deactivation of the electrical assistance mode due to any hazardous electric drive malfunction, the electric drive shall not start automatically without rider intervention (pedalling is not considered as rider intervention).</p>			P
4.2.13.2	Test method – Electric motor management			-
4.2.13.2.1	Test conditions			-
	<p>a) The test may be performed either on a test track, a test bench or on a stand which keeps the motor driven wheel free of the ground;</p> <p>b) The test track shall be according to</p>			P

EN 15194				
Clause	Requirement	Test	Result – Remark	Verdict
	4.2.13.2.2; c) The time-measuring device shall have an accuracy of $\pm 2\%$; d) The ambient temperature shall be between $5\text{ }^{\circ}\text{C}$ and $35\text{ }^{\circ}\text{C}$; e) Maximum wind speed shall not exceed 3 m/s; f) The battery shall be fully charged according to the manufacturer's instructions; g) Speed measurement shall have an accuracy of $\pm 2\%$. The test to ensure the compliance to this clause shall be adapted to the technology used; for example: — pedal backwards and check the no load current point (see 3.48); or			
	— pedal backwards and check that no torque is delivered on the driving wheel. For the test, the worst case conditions of gear ratio and speed shall be applied. The worst condition for speed is defined as 90 % of cut off speed (see 3.23).			P
4.2.13.2.2	Test track			-
	The gradient of the track shall not exceed 0,5 %. If the gradient is less than 0,2 % carry out all runs in the same direction. If the gradient lies between 0,2 % and 0,5 % carry out alternate runs in opposite directions. The surface shall be hard, of concrete or fine asphalt free from loose dirt or gravel. The minimum coefficient of friction between the dry surface and the bicycle tyre shall be 0,75.			P
4.2.13.2.3	Test procedure			-
	a) Pedal backwards and check that no electric motor assistance is provided. The test to ensure the compliance to this clause shall be adapted to the technology used. b) Check the cut off distance: 1) pedal so that the EPAC reach 90 % of the cut off speed; 2) stop pedalling without braking; 3) measure the cut off distance; 4) carry out the test three times; the result is the average of this measurement after rejection of invalid points. c) If braking device cut-off switches are fitted, actuate each brake device separately and verify the initiation of the cut off signal while pedalling.			P
4.2.14	Maximum power measurement — Measurement at the engine shaft			-
	The maximum continuous rated power shall be measured according to EN 60034-1 when the motor reaches its thermal equilibrium as specified by the manufacturer. NOTE Thermal equilibrium: temperatures of motor parts do not vary more than 2K per hour.			P

EN 15194				
Clause	Requirement	Test	Result – Remark	Verdict
	In circumstance where the power is measured directly at the shaft of the electronic motor, the result of the measurement shall be divided by 1,10 to consider the measurement uncertainty and then divided by 1,05 to include for example the transmission losses, unless the real values of these losses are determined.			
4.2.15	Electro Magnetic Compatibility			-
4.2.15.1	Emission			-
	The EPAC and ESA shall fulfil the requirements of Annex C.			P
4.2.15.2	Immunity			-
	The EPAC and ESA shall fulfil the requirements of Annex C.			P
4.2.15.3	Battery charger			-
	As an EPAC is not intended to be used while charging on the electric network, for integrated charger the whole EPAC plus integrated charger shall be tested for EMC according to the applicable standards based on the European EMC directive. NOTE The following European Standards are applicable for battery chargers to be used in residential environment: EN 55014–1, EN 55014–2, EN 61000–3-2, EN 61000–3-3.			P
4.2.16	Failure mode			-
4.2.16.1	Requirements			-
	It shall be possible to ride the EPAC by pedalling even if the assistance failed.			P
4.2.17	Anti-tampering measure			-
4.2.17.1	General			-
	Anti-tampering measures apply to tampering or modifications that general consumers carry out concerning the control unit, drive unit or other parts of power assisting system by using commercially available tools, equipment or parts.			P
4.2.17.2	Prevention of tampering of the motor			-
	The following anti-tampering requirements shall be taken into account: a) Anti-tampering relevant parameters indicated below shall only be accessible to the manufacturer or authorized persons and changes of software configuration parameters require programming tools that are not commercially available or security protected: 1) maximum speed with motor assistance (all systems), 2) parameters affecting the maximum vehicle speed limited by design, 3) maximum gear ratio (system with middle motors), 4) maximum motor power (all systems), 5) maximum speed of starting up			P

EN 15194				
Clause	Requirement	Test	Result – Remark	Verdict
	<p>assistance;</p> <p>b) Assumable manipulations on the approval relevant configuration shall be prevented or compensated by effective counter measures, i.e. plausibility logics to detect manipulations on sensors;</p> <p>c) Closed set of components (i.e. operation only with released battery);</p> <p>d) Protection against opening of relevant components without traces (sealing).</p>			
4.3	Mechanical requirements			-
4.3.1	General			-
4.3.1.1	Definition of brake tests			-
	Brake tests to which accuracy requirements apply, as in 4.3.1.4, are those specified in 4.3.5.3 to 4.3.5.6 inclusive.			P
4.3.1.2	Definition of strength tests			-
	Strength tests to which accuracy requirements apply, as in 4.3.1.4, are those involving static, impact or fatigue loading as specified in 4.3.5.6 to 4.3.12, 4.3.13 inclusive and 4.3.19.2.			P
4.3.1.3	Numbers and condition of specimens for the strength tests			-
	<p>In general, for static, impact and fatigue tests, each test shall be conducted on a new test sample, but if only one sample is available, it is permissible to conduct all of these tests on the same sample with the sequence of testing being fatigue, static and impact.</p> <p>When more than one test is conducted on the same sample, the test sequence shall be clearly recorded in the test report or record of testing.</p> <p>NOTE It will be noted that if more than one test is conducted on the same sample, earlier tests can influence the results of subsequent tests.</p> <p>Also, if a sample fails when it has been subjected to more than one test, a direct comparison with single testing is not possible.</p> <p>In all strength tests, specimens shall be in the fully-finished condition.</p>			P
4.3.1.4	Accuracy tolerances of test conditions for brake tests and strength tests			-
	<p>Unless stated otherwise, accuracy tolerances based on the nominal values shall be as follows:</p> <p>Forces and torques 0/+5 %</p> <p>Masses and weights ±1 %</p> <p>Dimensions ±1 mm</p> <p>Angles ±1°</p> <p>Time duration ±5 s</p> <p>Temperatures ±2 °C</p> <p>Pressures ±5 %</p>			P
4.3.1.5	Fatigue test			-
	<p>The force for fatigue tests shall be applied and released progressively, not to exceed 10 Hz.</p> <p>The tightness of fasteners according to</p>			P

EN 15194				
Clause	Requirement	Test	Result – Remark	Verdict
	manufacturer's recommended torque can be re-checked not later than 1 000 test cycles to allow for the initial settling of the component assembly. (This is considered applicable to all components, where fasteners are present for clamping.) The test bench shall be qualified to meet dynamic requirements of 4.3.1.4. NOTE Examples of suitable methods are listed in Bibliography [6].			
4.3.1.6	Fatigue test for composite components			-
	For fatigue test for composite components, the initial value of displacement (peak-to-peak value) is taken after 1 000 cycles and before 2 000 cycles.			P
4.3.1.7	Plastic material test ambient temperature			-
	All strength tests involving any plastic materials shall be pre-conditioned for two hours and tested at an ambient temperature of 23 °C ± 5 °C.			P
4.3.1.8	Crack detection methods			-
	Standardized methods should be used to emphasize the presence of cracks where visible cracks are specified as criteria of failure in tests specified in this standard. NOTE For example, suitable dye-penetrant methods are specified in EN ISO 3452-1 [18], EN ISO 3452-2 [19], EN ISO 3452-3 [20] and EN ISO 3452-4 [21]. In addition, white paint or surface treatment can be used to aid in detection for composite materials.			P
4.3.2	Sharp edges			-
	Exposed edges that could come into contact with the rider's hands, legs, etc., during normal riding or normal handling and normal maintenance shall not be sharp, e.g. deburred, broken, rolled or processed with comparable techniques. NOTE It is advised to refer to ISO 13715 [29].			P
4.3.3	Security and strength of safety-related fasteners			-
4.3.3.1	Security of screws			-
	Any screws used in the assembly of suspension systems or screws used to attach bracket attached electric generators, brake-mechanisms and mud-guards to the frame or fork, and the saddle to the seat-post shall be provided with suitable locking devices, e.g. lock-washers, lock-nuts, thread locking compound or stiff nuts. NOTE 1 The screws used to attach hub-generator are not included. NOTE 2 Fasteners used to assemble hub and disc brakes will preferably have heat-resistant locking devices.			P
4.3.3.2	Minimum failure torque			-
	The minimum failure torque of bolted joints for the fastening of handle bars, handlebar-stems,			P

EN 15194				
Clause	Requirement	Test	Result – Remark	Verdict
	bar-ends, saddle and seat-posts shall be at least 50 % greater than the manufacturer's recommended tightening torque.			
4.3.3.3	Folding bicycles mechanism			-
	If provided, folding bicycle mechanism shall be designed so that EPAC can be locked for use in a simple, stable, safe way and when folded no damage shall occur to any cables. No locking mechanism shall contact the wheels or tyres during riding, and it shall be impossible to unintentionally loosen or unlock the folding mechanisms during riding.			N/A
4.3.4	Protrusions			-
	These requirements are intended to address the hazards associated with the users of EPACs falling on projections or rigid components (e.g. handlebars, levers) on EPAC possibly causing internal injury or skin puncture. Tubes and rigid components in the form of projections which constitute a puncture hazard to the rider should be protected. The size and shape of the end protection has not been stipulated, but an adequate shape shall be given to avoid puncturing of the body. Screw threads which constitute a puncture hazard shall be limited to a protrusion length of one major diameter of the screw beyond the internally threaded mating part. NOTE Handlebar-ends are covered by the paragraph in 4.3.6.2.			P
4.3.5	Brakes			-
4.3.5.1	Braking-systems			-
	EPAC shall be equipped with at least two independently actuated braking-systems. At least one shall operate on the front wheel and one on the rear wheel. The braking-systems shall operate without binding and shall be capable of meeting the braking-performance requirements of 4.3.5.9. No hand shall need to be taken from the handlebar to operate the brake levers. If additional braking-systems are implemented, they shall meet the brake requirements of 4.3.5. Brake-blocks containing asbestos shall not be used.			P
4.3.5.2	Hand-operated brakes			-
4.3.5.2.1	Brake-lever position			-
	The brake levers for front and rear brakes shall be positioned according to the legislation or custom and practice of the country in which EPAC is to be sold, and EPAC manufacturer shall state in the manufacturer's instructions which levers operate the front and rear brakes (see also Clause 6 i)).			P
4.3.5.2.2	Brake-lever grip dimensions			-

EN 15194

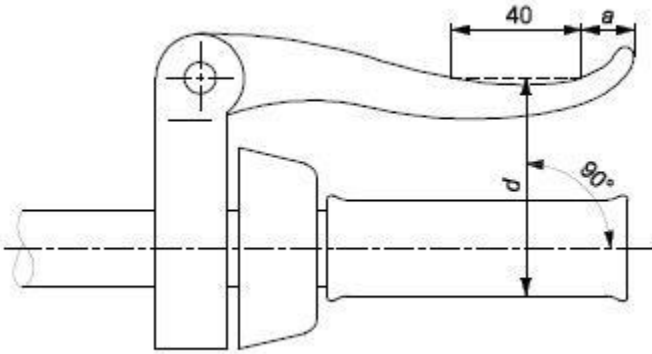
Clause	Requirement	Test	Result – Remark	Verdict
4.3.5.2.2.1	<p>Requirement</p> <p>The dimension, d, measured between the outer surfaces of the brake-lever in the region intended for contact with the rider's fingers and the handlebar or any other covering present shall over a distance of not less than 40 mm as shown in Figure 1 not exceed 90 mm. Conformance shall be established by the method detailed in 4.3.5.2.2.2.</p> <p>The range of adjustment on the brake-lever ought to permit these dimensions to be obtained.</p>			- P
 <p>Key</p> <p>a distance between the last part of the lever intended for contact with the rider's fingers and the end of the lever</p> <p>d brake-lever grip dimension</p> <p>Figure 1 — Brake-lever grip dimensions</p>				
4.3.5.2.2.2	<p>Test method for the brake-lever similar</p> <p>Fit the gauge illustrated in Figure 2 — over the handlebar-grip or the handlebar (when the manufacturer does not fit a grip) and the brake-lever as shown in Figure 3 — so that the face A is in contact with the handlebar or grip and the side of the brake-lever. Ensure that the face B spans an area of that part of the brake-lever which is intended for contact with the rider's fingers without the gauge causing any movement of the brake-lever towards the handlebar or grip. Measure the distance a, the distance between the last part of the lever intended for contact with the rider's fingers and the end of the lever.</p> <p>The measurement ought to be conducted only on a fully-assembled bicycle.</p>			- P

EN 15194

Clause	Requirement	Test	Result – Remark	Verdict
--------	-------------	------	-----------------	---------

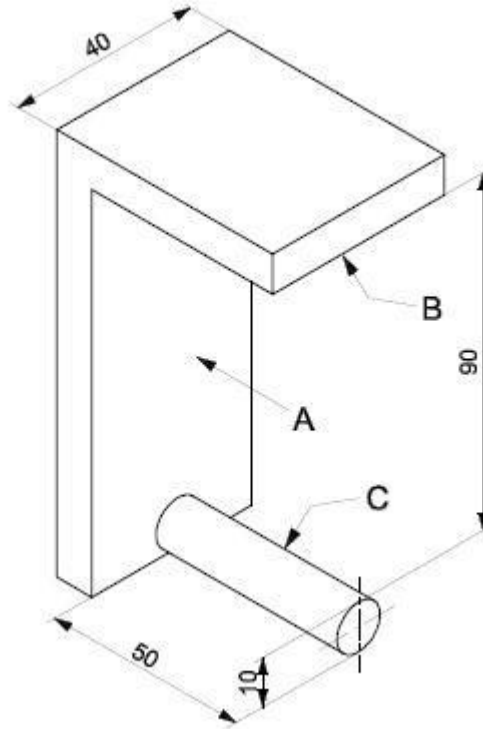

Key

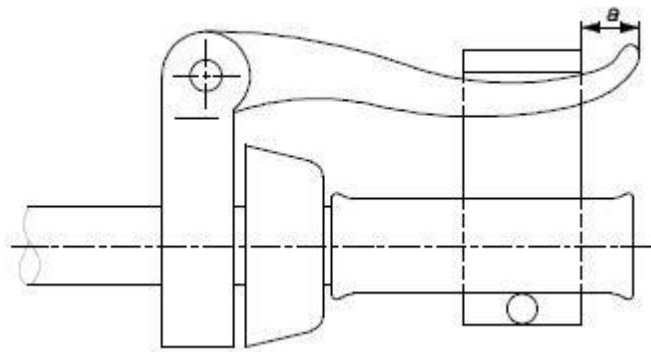
- A face A
- B face B
- C rod

Figure 2 — Brake-lever grip dimension gauge

Figure 3 — Method of fitting the gauge to the brake-lever and handlebar (Minimum grip length is shown)

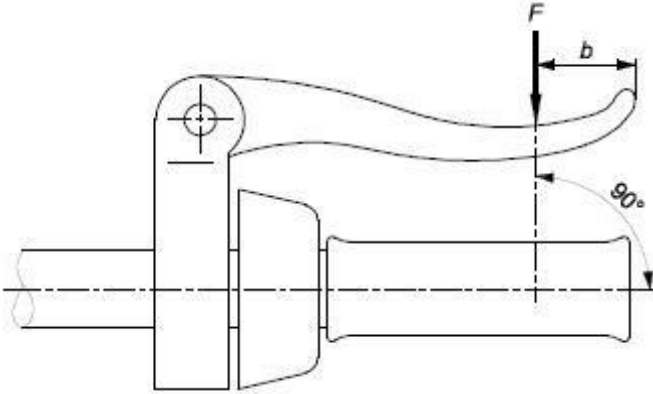
4.3.5.3	Attachment of brake assembly and cable requirements		-
	Cable pinch-bolts shall not sever any of the cable strands when assembled to the manufacturer's instructions. In the event of a cable failing, no part of the brake mechanism shall inadvertently inhibit the rotation of the wheel. The cable end shall either be protected with a cap that shall withstand a removal force of not		P

EN 15194

Clause	Requirement	Test	Result – Remark	Verdict
	less than 20 N or be otherwise treated to prevent unravelling. NOTE See 4.3.3 in relation to fasteners.			
4.3.5.4	Brake-levers – Position of applied force			-
	For the purposes of braking tests in this standard, for brake-levers similar to Type A, the test force shall be applied at a distance, b , which is equal to either dimension a as determined in 4.3.5.2.2.2 or 25 mm from the free end of the brake-lever, whichever is the greater (see Figure 4).			P
 <p>Key F applied force $B = 25$ mm or dimension a, whichever is greater</p> <p>Figure 4 — Position of applied force on the brake-lever type A</p>				
4.3.5.5	Brake-block and brake-pad assemblies – Safety test			-
4.3.5.5.1	Requirement			-
	The friction material shall be securely attached to the holder, backing-plate, or shoe and there shall be no failure of the braking system or any component thereof when tested by the method specified in 4.3.5.5.2.			P
4.3.5.6	Brake adjustment			-
	Each brake shall be equipped with an adjustment mechanism either manual or automatic. Each brake shall be capable of adjustment with or without the use of a tool to an efficient operating position until the friction material has worn to the point of requiring replacement as recommended in the manufacturer's instructions. Also, when correctly adjusted, the friction material shall not contact anything other than the intended braking surface. The brake blocks of a bicycle with rod brakes shall not come into contact with the rim of the wheels when the steering angle of the handlebars is set at 60° , nor shall the rods be bent, or be twisted after the handlebars are reset to the central position.			P

EN 15194				
Clause	Requirement	Test	Result – Remark	Verdict
4.3.5.7	Hand-operated braking-system – Strength test			-
4.3.5.7.1	Requirement			-
	When tested by the method described in 4.3.5.7.2, there shall be no failure of the braking-system or of any component thereof.			P
4.3.5.8	Back-pedal braking system – Strength test			-
4.3.5.8.1	General			-
	If a back-pedal braking system is fitted, the brake shall be actuated by the operator's foot applying force to the pedal in a direction opposite to that of the drive force. The brake mechanism shall function regardless of any drive-gear positions or adjustments. The differential between the drive and brake positions of the crank shall not exceed 60°. The measurement shall be taken with the crank held against each position with a pedal force of at least 250 N. The force shall be maintained for 1 min in each position.			N/A
4.3.5.8.2	Requirement			-
	When tested in accordance with 4.3.5.8.3, there shall be no failure of the brake system or any component thereof.			N/A
4.3.5.9	Braking performance			-
4.3.5.9.1	General			-
	The progressive characteristics of the brake are determined by linearity measurements. A final, simple track test checks for smooth, safe, stopping characteristics. NOTE See 4.3.5.9.5.6 h) "Test method —simple track test". Conduct the braking-performance test on a fully-assembled bicycle after the brakes have been subjected to the strength test detailed in 4.3.5.7, 4.3.5.8. Before testing the bicycle, inflate the tyres and adjust the brakes all according to the manufacturer's instructions, but in the case of rim-brakes to the maximum clearance specified by the manufacturer.			P
4.3.5.9.2	Requirements			-
	Where EPAC is fitted with secondary brake-levers attached to brake-levers, bar-ends or aerodynamic extensions, separate tests shall be conducted for the operation of the secondary brake-levers in addition to tests with the normal levers.			P
	When tested in accordance with 4.3.5.9.5, the bicycle shall fulfil the requirements shown in Table 1.			P

EN 15194

Clause	Requirement	Test	Result – Remark	Verdict
--------	-------------	------	-----------------	---------

Table 1 — Calculated braking performance value
Forces in N

Condition	Brake in use	Minimum braking performance value, B_p
Dry	Front only	340
	Rear only	220
Wet	Front only	220
	Rear only	140

NOTE These values are based on the reference mass "m" (100 kg).

4.3.5.9.3	Linearity requirements		-
	When tested by the methods described in 4.3.5.9.5.6 c) 1) and 2), the braking force <i>FBr average</i> shall be linearly proportional (within $\pm 20\%$) to the progressively increasing intended operating forces <i>FOp intend</i> . The requirement applies to braking forces <i>FBr average</i> equal to and greater than 80 N (according to Annex F).		P
4.3.5.9.4	Ratio between wet and dry braking performance requirements		-
4.3.5.10	Brakes – Heat-resistance test		-
4.3.5.10.1	General		-
	This test applies to all disc- and hub-brakes but to rim-brakes only where they are known or suspected to be manufactured from or include thermoplastic materials. Each brake on the bicycle shall be tested individually, but where the front and rear brakes are identical only one brake need be tested.		P
4.3.5.10.2	Requirement		-
	Throughout the test described in 4.3.5.10.3, the brake-lever shall not touch the handlebar-grip, the operating force shall not exceed 180 N, and the braking force shall not deviate outside the range 60 N to 115 N. Immediately after having been subjected to the test described in 4.3.5.10.3, the brakes shall achieve at least 60 % of the braking performance which was recorded at the highest operating force used during the performance tests 4.3.5.9.5.6 c) 1) and 2).		P
4.3.5.11	Back-pedal brake linearity test		-
	This test shall be conducted on a fully assembled EPAC. The output force for a back-pedal brake shall be measured tangentially to the circumference of the rear tyre, when the wheel is rotated in the direction of forward movement, while a force of between 90 N and 300 N is being applied to the pedal at right		P

EN 15194

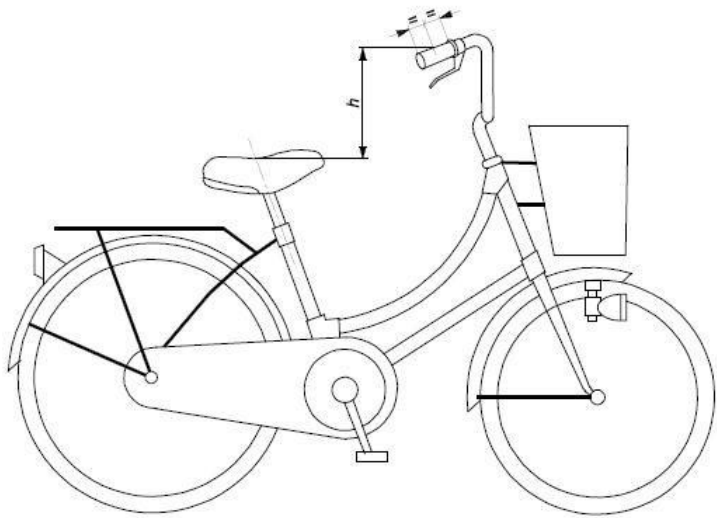
Clause	Requirement	Test	Result – Remark	Verdict
	angles to the crank and in the direction of braking. The braking force reading shall be taken during a steady pull and after one revolution of the wheel. A minimum of five results, each at a different pedal force level, shall be taken. Each result shall be the average of three individual readings at the same load level. The results shall be plotted on a graph, showing the line of best fit and the $\pm 20\%$ limit lines obtained by the method of least squares outlined in Annex F.			
4.3.6	Steering			-
4.3.6.1	Handlebar – Dimensions			-
	Adjust the handlebar height to its highest normal riding position and the saddle to its lowest normal riding position as specified by the manufacturer (see Clause 6 i)). Measure the vertical distance from the centre and top of the handlebar grips to a point where the saddle surface is intersected by the seat post axis (see Figure 9). This dimension shall not exceed 400 mm.			P
 <p>Key H vertical distance</p> <p>Figure 9 — Vertical distance between the handlebar grips and the seat surface</p>				
4.3.6.2	Handlebar grips and plugs			-
4.3.6.2.1	Requirements			-
	The ends of the handlebar shall be fitted with handgrips or end plugs. When tested by the method described in 4.3.6.2.2 and 4.3.6.2.3, the handgrips or plugs shall withstand the specified removal forces.			P
4.3.6.2.2	Freezing test method			-
	Immerse the handlebar, with handlebar grips or plugs fitted, in water at room temperature for			P

EN 15194

Clause	Requirement Test	Result – Remark	Verdict
	<p>one hour and then place the handlebar in a freezer until the handlebar is at a temperature lower than -5°C. Remove the handlebar from the freezer and allow the temperature of the handlebar to reach -5°C, and then apply a force of 70 N to the grip or plug in the loosening direction as shown in Figure 10. Maintain the force until the temperature of the handlebar has reached $+5^{\circ}\text{C}$.</p> <p>It shall be permitted to create a hole in the plug to allow for the testing fixture to be fitted so long as the hole does not affect the seat of the plug in the handlebar and the fixture does not contact the handlebar during the test.</p>		
<div style="text-align: center;"> <p>Key</p> <ul style="list-style-type: none"> 1 handlebar grip 2 handlebar 3 drawing attachment 4 hooking ring 5 clearance <p>NOTE It is possible that the hooking ring be divided.</p> <p>Figure 10 — Example of handlebar grip drawing attachment</p> </div>			
4.3.6.3	<p>Handlebar stem – Insertion-depth mark or positive stop</p>		-
	<p>The handlebar-stem shall be provided with one of the two following alternative means of ensuring a safe insertion depth into the fork steerer:</p> <p>a) it shall contain a permanent, transverse mark, of length not less than the external diameter of the stem, that clearly indicates the minimum insertion depth of the handlebar-stem into the fork steerer. The insertion mark shall be located at a position not less than 2,5 times the external diameter of the handlebar-stem from the bottom of the stem, and there shall be at least one</p>		P

EN 15194

Clause	Requirement	Test	Result – Remark	Verdict
	stem diameter's length of contiguous, circumferential stem material below the mark; b) it shall incorporate a permanent stop to prevent it from being drawn out of the fork steerer such as to leave the insertion less than the amount specified in a) above.			
4.3.6.4	Handlebar stem to fork steerer – Clamping requirements			-
	The distance <i>g</i> , see Figure 11, between the top of the handlebar stem and the top of the fork steerer to which the handlebar stem is clamped shall not be greater than 5 mm. The upper part of the fork steerer to which the handlebar stem is clamped shall not be threaded. The dimension <i>g</i> shall also ensure that the proper adjustment of the steering system can be achieved. For aluminium and composite fork steerer any internal device that could damage the internal surface of the fork steerer shall be avoided.			P
Key <i>g</i> distance between the upper, clamping part of the handlebar stem and the upper, part of the fork steerer 1 handlebar stem 2 fork steerer 3 spacer-rings 4 head set 5 head-tube				
Figure 11 — Clamping between the handlebar stem and fork steerer				
4.3.6.5	Steering stability			-
	The steering shall be free to turn through at least 60° either side of the straight-ahead position and shall exhibit no tight spots, stiffness or slackness in the bearings when correctly adjusted. A minimum of 25 % of the total mass of EPAC and rider shall act on the front wheel when the rider is holding the handlebar grips and sitting on the saddle, with the saddle and rider in their most rearward positions. NOTE Recommendations for steering geometry			P

EN 15194				
Clause	Requirement	Test	Result – Remark	Verdict
		are given in Annex E.		
4.3.6.6	Steering assembly – Static strength and safety tests			-
4.3.6.6.1	Handlebar and stem assembly – Lateral bending test			-
4.3.6.6.1.1	General			-
		This test is for manufacturers who produce handlebars and stems or for cycle manufacturers.		P
4.3.6.6.1.2	Requirement			-
		When tested by the method described in 4.3.6.6.1.3, there shall be no cracking or fracture of the handlebar, stem or clamp-bolt and the permanent deformation measured at the point of application of the test force shall not exceed 15 mm.		P
4.3.6.6.2	Handlebar-stem – Forward bending test			-
4.3.6.6.2.1	General			-
		Conduct the test in two stages on the same assembly as follows.		P
4.3.6.6.2.2	Requirement for Stage 1			-
		When tested by the method described in 4.3.6.6.2.3, there shall be no visible cracks or fractures and the permanent deformation measured at the point of application of the test force and in the direction of the test force shall not exceed 10 mm.		P
4.3.6.6.3	Handlebar to handlebar-stem – Torsional safety test			-
4.3.6.6.4	Handlebar-stem to fork steerer – Torsional safety test			-
4.3.6.6.5	Bar-end to handlebar – Torsional safety test			-
4.3.6.7	Handlebar and stem assembly – Fatigue test			-
4.3.6.7.1	General			-
		Handlebar-stems can influence test failures of handlebars and for this reason, a handlebar shall always be tested mounted in a stem, but it is permitted to test a stem with a solid bar in place of the handlebar and bar-ends with dimensions corresponding to handlebars/bar-ends suitable for that stem. When the fatigue test is for the stem only, the manufacturer of the stem shall specify the types and sizes of handlebar for which the stem is intended and the test shall be based on the most severe combination. Conduct the test in two stages on the same assembly.		P
4.3.7	Frames			-
4.3.7.1	Suspension-frames – Special requirement			-
		The design shall be such that if the spring or damper fails, neither the tyre shall contact any part of the frame nor the assembly carrying the rear wheel become detached from the rest of the frame.		P
4.3.7.2	Frame – Impact test (falling mass)			-

EN 15194

Clause	Requirement	Test	Result – Remark	Verdict						
4.3.7.2.1	Requirements			-						
	<p>When tested by the method described in 4.3.7.2.3, there shall be no visible cracks or fractures of the frame.</p> <p>The permanent deformation measured between the axes of the wheel axles shall not exceed the following values:</p> <p>a) 30 mm where a fork is fitted;</p> <p>b) where a dummy fork is fitted in place of a fork, the values are given in Table 9.</p> <p>NOTE See Annex E (normative) Dummy fork characteristics.</p>			P						
Table 9 — The values of permanent deformation										
<table border="1"> <thead> <tr> <th>Fork type</th> <th>Real fork</th> <th>Dummy fork</th> </tr> </thead> <tbody> <tr> <td>Permanent deformation</td> <td>30 mm</td> <td>10 mm</td> </tr> </tbody> </table>					Fork type	Real fork	Dummy fork	Permanent deformation	30 mm	10 mm
Fork type	Real fork	Dummy fork								
Permanent deformation	30 mm	10 mm								
4.3.7.2.2	General			-						
	<p>Manufacturers of frames are permitted to conduct the test with a dummy fork (see Annex E) fitted in place of a front fork.</p> <p>Where a frame is convertible for male and female riders by the removal of a bar, test it with the bar removed.</p> <p>Where a suspension fork is fitted, test the assembly with the fork extended to its unloaded free length. Where a rear suspension system is incorporated in the frame, secure the suspension in a position equivalent to that which would occur with a 90 kg rider seated on the bicycle. If the type of suspension system does not permit it to be locked, then replace the spring/damper unit by a solid link of the appropriate size and with end fittings similar to those of the spring/damper unit.</p>			P						
4.3.7.3	Frame and front fork assembly – Impact test (falling frame)			-						
4.3.7.3.1	General			-						
	<p>Manufacturers of complete EPACs shall conduct the test with the frame fitted with the appropriate front fork.</p> <p>Where a frame is convertible for male and female riders by the removal of a bar, test it with the bar removed.</p> <p>Where a suspension fork is fitted, it shall be at its unloaded length prior to the impact. If the spring damper unit can be locked, it shall be locked in its unloaded length position. If the spring/damper cannot be locked, use one of the two following alternative procedures:</p> <p>a) secure the fork at its extended length by an external locking method, or</p> <p>b) replace the fork by a rigid fork which is known to meet the requirements of the</p>			P						

EN 15194				
Clause	Requirement	Test	Result – Remark	Verdict
	<p>impact test described in 4.3.8.5 and of a length which is consistent with an 90 kg rider seated in a normal riding position on the bicycle when it is equipped with the suspension fork.</p> <p>Where a rear suspension system is incorporated in the frame, secure the spring/damper unit in a position equivalent to that which would occur with an 90 kg rider seated on the bicycle; if the type of suspension system does not permit it to be locked, then replace the spring/damper unit by a solid link of the appropriate size and with end fittings similar to those of the spring/damper unit.</p>			
4.3.7.4	Frame – Fatigue test with pedalling forces			-
4.3.7.4.1	General			-
	<p>All types of frame shall be subjected to this test. In tests on suspension-frames with pivoted joints, adjust the spring, air-pressure, or damper to provide maximum resistance, or, for a pneumatic damper in which the air-pressure cannot be adjusted, replace the suspension-unit with a rigid link, ensuring that its end fixings and lateral rigidity accurately simulate those of the original unit. For suspension-frames in which the chain-stays do not have pivots but rely on flexing, ensure that any dampers are set to provide the minimum resistance in order to ensure adequate testing of the frame.</p> <p>Where a suspension-frame has adjustable brackets or linkages to vary the resistance of the bicycle against the ground-contact forces or to vary the attitude of the bicycle, arrange the positions of these adjustable components to ensure maximum forces in the frame.</p>			P
4.3.7.4.2	Requirement			-
	<p>When tested by the method described in 4.3.7.4.3, there shall be no visible cracks or fractures in any part of the frame, and there shall be no separation of any parts of the suspension system.</p> <p>For composite frames, the running displacements (peak-to-peak values) at the points where the test forces are applied shall not increase by more than 20 % of the initial values (see 4.3.1.6).</p>			P
4.3.7.5	Frame – Fatigue test with horizontal forces			-
4.3.7.5.1	General			-
	<p>Where a frame is convertible for male and female riders by the removal of a bar, remove the bar.</p> <p>It is not necessary for a genuine fork to be fitted, provided that any substitute fork is of the same length as the intended fork (see Annex F) and it is correctly installed in the steering-head bearings. For a suspension fork, lock it at a</p>			P

EN 15194				
Clause	Requirement	Test	Result – Remark	Verdict
	<p>length equivalent to that with an 90 kg rider seated on the bicycle either by adjusting the spring/damper or by external means.</p> <p>In tests on suspension frames with pivoted joints, lock the moving part of the frame into a position as would occur with a 90 kg rider seated on the bicycle. This may be achieved by locking the suspension unit in an appropriate position or, if the type of suspension system does not permit it to be locked, then the suspension system may be replaced by a solid link of the appropriate compressed size. Ensure that the axes of the front and rear axles are horizontally in line, as shown in Figure 22. For suspension-frames in which the chain-stays do not have pivots but rely on flexing, ensure that any dampers are set to provide the minimum resistance in order to ensure adequate testing of the frame.</p> <p>Where a suspension frame has adjustable brackets or linkages to vary the resistance of the bicycle against the ground-contact forces or to vary the attitude of the bicycle, arrange the positions of these adjustable components to ensure maximum forces in the frame.</p>			
4.3.7.5.2	Requirement			-
	<p>When tested by the method described in 4.3.7.5.3, there shall be no visible cracks or fractures in the frame and there shall be no separation of any parts of any suspension system.</p> <p>For composite frames, the running displacement (peak-to-peak value) at the point where the test forces are applied shall not increase by more than 20 % of the initial values (see 4.3.1.6).</p>			P
4.3.7.6	Frame – Fatigue test with a vertical force			-
4.3.7.6.1	General			-
	<p>Where a frame is convertible for male and female riders by the removal of a bar, remove the bar.</p> <p>Where a suspension frame has adjustable brackets or linkages to vary the resistance of the bicycle against the ground-contact forces or to vary the attitude of the bicycle, arrange the positions of these adjustable components to ensure maximum forces in the frame. Secure the rear suspension as described in 4.3.7.4.1.</p> <p>If a suspension fork is fitted lock it at a length equivalent to that with an 90 kg rider seated on the bicycle either by adjusting the spring/damper or by external means.</p>			P
4.3.7.6.2	Requirement			-
	<p>When tested by the method described in 4.3.7.6.3, there shall be no visible cracks or fractures in the frame and there shall be no</p>			P

EN 15194

Clause	Requirement	Test	Result – Remark	Verdict
	separation of any parts of the suspension system. For composite frames, the running displacement (peak-to-peak value) at the point where the test forces are applied shall not increase by more than 20 % of the initial value (see 4.3.1.6).			
4.3.8	Front fork			-
4.3.8.1	General			-
	4.3.8.2, 4.3.8.4, 4.3.8.5 and 4.3.8.6 apply to all types of fork. In the strength tests, 4.3.8.4, 4.3.8.5, 4.3.8.6 and 4.3.8.7, a suspension-fork shall be tested in its free, uncompressed length condition.			P
4.3.8.2	Means of location of the axle and wheel retention			-
	The slots or other means of location for the wheel-axle within the front fork shall be such that when the axle or cones are firmly abutting the top face of the slots, the front wheel remains central within the fork. The front fork and wheel shall also fulfil the requirements of 4.3.9.4 and 4.3.9.5.			P
4.3.8.3	Suspension-forks – Special requirements			-
4.3.8.3.1	Tyre-clearance test			-
4.3.8.3.1.1	Requirement			-
	When tested by the method described in 4.3.8.3.1.2, the tyre shall not contact the crown of the fork nor shall the components separate.			P
4.8.3.2	Tensile test			-
4.8.3.2.1	Requirement			-
	When tested by the method described in 4.3.8.3.2.2, there shall be no detachment or loosening of any parts of the assembly and the tubular, telescopic components of any fork-leg shall not separate under the test force.			P
4.3.8.4	Front fork – Static bending test			-
4.3.8.4.1	Requirement			-
	When tested by the method described in 4.3.8.4.2, there shall be no fractures or visible cracks in any part of the fork, and the permanent deformation, measured as the displacement of the axis of the wheel-axle or simulated axle in relation to the axis of the fork steerer, shall not exceed 10 mm.			P
4.3.8.5	Front fork – Rearward impact test			-
4.3.8.5.1	Forks made entirely of metal			-
4.3.8.5.1.1	Crown/steerer joint assembled by welding or brazing			-
	When tested by the method described in 4.3.8.5.3, there shall be no fractures or visible cracks in any part of the fork, and the permanent deformation, measured as the displacement of the axis of the wheel-axle or simulated axle in relation to the axis of the fork steerer, shall not exceed 45 mm.			P

EN 15194				
Clause	Requirement	Test	Result – Remark	Verdict
	If the fork is used in the frame impact test (falling-mass), 4.3.7.2, there is no need to perform this test.			
4.3.8.5.1.2	Crown/steerer joint assembled by press-fitting, bonding, or clamping			-
	When tested by the method described 4.3.8.5.4 a), if there are any fractures or visible cracks in any part of the fork, and the permanent deformation, measured as the displacement of the axis of the wheel-axle or simulated axle in relation to the axis of the fork steerer, exceeds 45 mm, the fork shall be considered to have failed. If the fork meets these criteria then it shall be subjected to a second test as described in 4.3.8.5.4 b), after which, it shall exhibit no fractures, then it shall be subjected to a third test as described in 4.3.8.5.4 c), irrespective of the amount of permanent deformation, there shall be no relative movement between the steerer and the crown.			P
4.3.8.5.2	Forks which have composite parts			-
	When tested by the method described in 4.3.8.5.3, there shall be no fractures in any part of a fork and the permanent deformation, measured as the displacement of the axis of the wheel-axle or simulated axle in relation to the axis of the fork steerer, shall not exceed 45 mm. After which, it shall exhibit no fractures, then it shall be subjected to a second test as described in 4.3.8.5.4 c) Torque on fork, irrespective of the amount of permanent deformation, there shall be no relative movement between the steerer and the crown.			P
4.3.8.6	Front fork – Bending fatigue test plus rearward impact test			-
4.3.8.6.1	Requirement			-
	When tested by the method described in 4.3.8.6.2, there shall be no fractures in any part of the fork, and the permanent deformation, measured as the displacement of the axis of the wheel-axle or simulated axle in relation to the axis of the fork steerer, shall not exceed 45 mm. For composite forks, the running displacement (peak-to-peak value) at the points where the test forces are applied shall not increase by more than 20 % of the initial values (see 4.3.1.6).			P
4.3.8.7	Forks intended for use with hub- or disc-brakes			-
4.3.8.7.1	General			-
	When a fork is intended for use with a hub- or disc-brake and whether supplied as original equipment or as an accessory, the fork manufacturer shall provide an attachment point on the fork-blade for the torque-arm or calliper. In tests conducted by the methods described in 4.3.8.7.3 and 4.3.8.7.5 and where more than			P

EN 15194

Clause	Requirement	Test	Result – Remark	Verdict
	one mounting-point is provided for a hub- or disc-brake, the following shall apply: a) Where a complete EPAC is supplied, the test adaptor shall be secured to the mounting-point used on EPAC. If bracket is supplied, it shall be used to perform the test; b) Where a fork is supplied as an accessory with more than one mounting-point, separate tests shall be conducted on each of the mounting-points on separate forks.			
4.3.8.7.2	Static brake-torque test			-
	When tested by the method described in 4.3.8.7.3, there shall be no fractures or visible cracks in any part of the fork.			P
4.3.8.7.3	Fork for hub/disc-brake – Static brake-torque test			-
	Mount the fork in a fixture representative of the head-tube according to Annex G and gripped in the normal head-bearings, fit an axle to the fork, and mount on the axle a pivoted, straight adaptor as shown in Figure 29 to provide a torque-arm of L_2 in length (see Table 20) and a suitable attachment for the brake mounting-point. If the wheel size is not listed in Table 20, the length L_2 shall be equal to one half of the wheel diameter. Apply a rearward force of 1 000 N to the torque arm perpendicular to the fork steerer axis and in the plane of the wheel. Maintain this force for 1 min, then reduce the force to 100 N and record any permanent deformation.			P
Table 20 — Fixture length				
Dimensions in millimetres				
Wheel diameter	24"	26"	650b	29" or 700c
Arm Length, L_2	305	330	349	368
Key 1 rigid mount incorporating head bearings 2 brake mounting-point 3 test adaptor				
Figure 29 — Fork for hub/disc-brake: static brake-torque test				
4.3.8.7.4	Fork for hub/disc-brake – Brake mount fatigue test			-
	When tested by the method described in 4.3.8.7.5, there shall be no fractures or visible cracks in any part of the fork and, in the case of suspension-forks, there shall be no separation			P

EN 15194

Clause	Requirement	Test	Result – Remark	Verdict
--------	-------------	------	-----------------	---------

		of any parts.		
4.3.8.7.5	Fork for hub/disc-brake – Brake mount fatigue test			-
	Mount the fork in a fixture representative of the head-tube according to Annex G and gripped in the normal head-bearings, fit an axle to the fork, and mount on the axle a pivoted, straight adaptor as shown in Figure 30 to provide a torque-arm of L_2 in length (see Table 21) and a suitable attachment for the brake mounting-point. Apply repeated, horizontal, dynamic forces of 600 N rearward to the end of the torque-arm parallel to the plane of the wheel (as shown in Figure 30) for C_2 cycles (see Table 21). The maximum test frequency shall be maintained as specified in 4.3.1.6.			P

Table 21 – Minimum test cycles

Test cycles, C_2	12 000
--------------------	--------

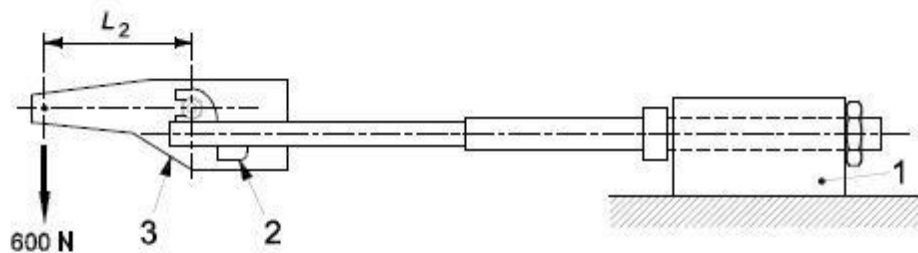
Key

- 1 rigid mount incorporating head bearings
- 2 brake mounting-point
- 3 test adaptor

Figure 30 – Fork for hub/disc-brake: Brake mount fatigue test

4.3.8.8	Tensile test for a non-welded fork			-
4.3.8.8.1	General			-
	This test is for forks where the blades and/or the fork steerer are secured in the fork-crown by press-fitting, clamping, adhesives, or any method other than brazing or welding. NOTE It may be convenient to combine this test with the wheel retention test, 4.3.9.4.2.			P-
4.3.8.8.2	Requirement			-
	When tested by the method described in 4.3.8.8.3, there shall be no detachment or loosening of any parts of the assembly.			P-
4.3.9	Wheels and wheel/tyre assembly			-
4.3.9.1	Wheels/tyre assembly – Concentricity tolerance and lateral tolerance			-

EN 15194

Clause	Requirement	Test	Result – Remark	Verdict						
4.3.9.1.1	Requirements			-						
	When measured by the method described in 4.3.9.1.2, the run-out shall not exceed the values which are given in Table 22.			P						
Table 22 — Wheel/tyre assembly – Concentricity and lateral tolerance Dimensions in millimetres <table border="1" style="margin: 10px auto;"> <thead> <tr> <th></th> <th>Intended for rim-brakes</th> <th>Not intended for rim-brakes</th> </tr> </thead> <tbody> <tr> <td>Concentricity and lateral tolerance</td> <td style="text-align: center;">1</td> <td style="text-align: center;">2</td> </tr> </tbody> </table>						Intended for rim-brakes	Not intended for rim-brakes	Concentricity and lateral tolerance	1	2
	Intended for rim-brakes	Not intended for rim-brakes								
Concentricity and lateral tolerance	1	2								
4.3.9.2	Wheel/tyre assembly – Clearance			-						
	Alignment of the wheel assembly in EPAC shall allow not less than the clearance values given in Table 23 between the tyre and any frame or fork element or a front mudguard and its attachment bolts.			P						
Table 23 — Wheel/tyre assembly – Clearance Dimensions in millimetres <table border="1" style="margin: 10px auto;"> <tbody> <tr> <td style="text-align: center;">Clearance</td> <td style="text-align: center;">6</td> </tr> </tbody> </table> <p>NOTE Where EPAC has a frame or a fork with a suspension system, the values in Table 23 apply to the suspension system in its uncompressed state. Clearance requirements for the frame or fork under a load are specified in 4.3.8.3.1.</p>					Clearance	6				
Clearance	6									
4.3.9.3	Wheel/tyre assembly – Static strength test			-						
4.3.9.3.1	Requirement			-						
	When a fully assembled wheel fitted with a tyre inflated to the maximum inflation pressure is tested by the method described in 4.3.9.3.2, there shall be no failure of any of the components of the wheel, and the permanent deformation, measured at the point of application of the force on the rim, shall not exceed the values which are given in Table 24.			P						
Table 24 — The values of permanent deformation Dimensions in millimetres <table border="1" style="margin: 10px auto;"> <tbody> <tr> <td style="text-align: center;">Permanent deformation</td> <td style="text-align: center;">1,5</td> </tr> </tbody> </table>					Permanent deformation	1,5				
Permanent deformation	1,5									
4.3.9.4	Wheels – Wheel retention			-						
4.3.9.4.1	General			-						
	Wheel retention safety is related to the combination of wheel, retention device, and drop-out design. Wheels shall be secured to EPAC frame and fork such that when adjusted to the manufacturer's instructions they comply with 4.3.9.4.2, 4.3.9.4.3 and 4.3.9.5. Wheel nuts shall have a minimum removal torque of 70 % of the manufacturer's recommended tightening torque. Where quick-release axle devices are used they			P						

EN 15194				
Clause	Requirement	Test	Result – Remark	Verdict
	shall comply with 4.3.9.5.			
4.3.9.4.2	Wheel retention – Retention devices secured			-
4.3.9.4.2.1	Requirement			-
	When tested by the method described in 4.3.9.4.2.2, there shall be no relative motion between the axle and the front fork/frame.			P
4.3.9.4.3	Front wheel retention – Retention devices unsecured			-
	<p>EPAC shall be equipped with secondary retention system that retains the front wheel in the dropouts when the primary retention system is in the open (unlocked) position and wheel off the ground.</p> <p>Where threaded axles and nuts are fitted, and the nuts are unscrewed by at least 360° from the finger tight condition and the brake system disconnected or released, the wheel shall not detach from the front fork when a force of 100 N is applied radially outwards, in line with the drop-out slots, and maintained for 1 min.</p> <p>Where quick-release is fitted, and the quick-release lever is fully open and the brake system is disconnected or released, the wheel shall not detach from the front fork when a force of 100 N is applied to the wheel radially outwards, in line with the drop-out slots, and maintained for 1 min.</p>			P
4.3.9.5	Wheels – Quick-release devices – Operating features			-
	<p>Any quick-release device shall have the following operating features:</p> <ol style="list-style-type: none"> a) it shall be adjustable to allow setting for tightness; b) its form and marking shall clearly indicate whether the device is in the open or locked position; c) if adjustable by a lever, the force required to close a properly set lever shall not exceed 200 N and, at this closing force there shall be no permanent deformation of the quick-release device; d) the releasing force of the clamping device when closed shall not be less than 50 N; e) if operated by a lever, the quick-release device shall withstand without fracture or permanent deformation a closing force of not less than 250 N applied with the adjustment set to prevent closure at this force; f) the wheel retention with the quick-release device in the clamped position shall be in accordance with 4.3.9.4.2, 4.3.9.4.3; g) the front wheel retention with the quick-release device in the open position shall be in accordance with 4.3.9.4.3. <p>If applied to a lever, the forces specified in c), d),</p>			P

EN 15194				
Clause	Requirement	Test	Result – Remark	Verdict
	and e) shall be applied 5 mm from the tip end of the lever.			
4.3.10	Rims, tyres and tubes			-
4.3.10.1	General			-
	Non-pneumatic tyres are excluded from the requirements of 4.3.10.2 and 4.3.10.3.			P
4.3.10.2	Tyre inflation pressure			-
	The maximum inflation pressure recommended by the manufacturer shall be permanently marked on the side wall of the tyre so as to be readily visible when the latter is assembled on the wheel. If the rim manufacturer recommends a maximum tyre inflation pressure, it shall be clearly and permanently marked on the rim and also specified in the manufacturer's instructions. It is recommended that the minimum inflation pressure specified by the tyre manufacturer also be permanently marked on the side wall of the tyre.			P
4.3.10.3	Tyre and rim compatibility			-
	Tyres that comply with the requirements of ISO 5775-1 and rims that comply with the requirements of ISO 5775-2 are compatible. The tyre, tube and tape shall be compatible with the rim design. When inflated to 110 % of the maximum inflation pressure, determined by the lower value between maximum inflation pressures recommended on the rim or the tyre, for a period of not less than 5 min, the tyre shall remain intact on the rim. NOTE In the absence of suitable information from the above-mentioned International Standards, other publications are allowed to be used. See Bibliography [32], [30].			P
4.3.10.4	Rim-wear			-
	In the case where the rim forms part of a braking system and there is a danger of failure due to wear, the manufacturer shall make the rider aware of this danger by durable and legible marking on the rim, in an area not obscured by the tyre, (see also Clause 6 z) and 5.1). NOTE A symbol referring to the instruction manual is an acceptable marking for rims for wear. Where the rim is made of composite materials, the manufacturer shall include in the manufacturer's instructions warnings of the danger of rim failure caused by wear of the braking surfaces.			P
4.3.10.5	Greenhouse effect test for composite wheels			-
4.3.10.5.1	General			-
	This requirement is to ensure wheels made from composite materials that are subjected to high temperature conditions (i.e. such as car storage in direct sunlight) do not suffer concealed damage that could subsequently affect the			P

EN 15194				
Clause	Requirement	Test	Result – Remark	Verdict
	safety performance of the wheel during normal use.			
4.3.10.5.2	Requirement			-
	<p>When a fully assembled wheel made of composite material, fitted with the appropriate size tyre and inflated according to the lowest value between maximum inflation pressure recommended on the rim or the tyre, is tested by the method described as 4.3.10.5.3, there shall be:</p> <ul style="list-style-type: none"> — no failure of any of the components of the wheel; — no tyre separation from the rim during the test; — no increase in rim width greater than 5 % of the initial maximal width value; — compliance of lateral and concentricity tolerance according to 4.3.9.1; — compliance of tyre and rim compatibility according to 4.3.10.3; — compliance of static strength according to 4.3.9.3. 			P
4.3.11	Front mudguard			-
4.3.11.1	Requirements			-
	If front mudguard is fitted, when tested by the method described in the two-stage tests in 4.3.11.2 (for mudguard with stays) or 4.3.11.3 (for mudguard without stays), the front mudguard shall not prevent rotation of the wheel or obstruct steering.			P
4.3.12	Pedals and pedal/crank drive system			P
4.3.12.1	Pedal tread			-
4.3.12.1.1	Tread surface			-
	The tread surface of a pedal shall be secured against movement within the pedal assembly.			P
4.3.12.1.2	Toe Clips			-
	<p>Pedals intended to be used without toe-clips, or for optional use with toe-clips, shall have:</p> <ul style="list-style-type: none"> a) tread surfaces on the top and bottom surfaces of the pedal; or b) a definite preferred position that automatically presents the tread surface to the rider's foot. <p>Pedals designed to be used only with toe-clips or shoe-retention devices shall have toe-clips or shoe-retention devices securely attached and need not comply with the requirements of 4.3.12.1.2 a) and b).</p>			P
4.3.12.2	Pedal clearance			-
4.3.12.2.1	Ground clearance			-
	With EPAC un-laden, the pedal at its lowest point and the tread surface of the pedal parallel to the ground and uppermost where it has only one tread surface, EPAC shall be capable of being leaned over at an angle of θ from the			P

EN 15194

Clause	Requirement	Test	Result – Remark	Verdict								
	vertical before any part of the pedal touches the ground. The values are given in Table 26. When EPAC is equipped with a suspension system, this measurement shall be taken with the suspension adjusted to the softest condition and with EPAC depressed into a position such as would be caused by a rider weighing 90 kg.											
<p style="text-align: center;">Table 26 — The values of ground clearance</p> <p style="text-align: right;">Angle in degrees</p> <table border="1" style="margin-left: auto; margin-right: auto;"> <tr> <td style="padding: 5px;">Lean angle θ</td> <td style="padding: 5px; text-align: center;">25</td> </tr> </table>					Lean angle θ	25						
Lean angle θ	25											
4.3.12.2.2	Toe clearance			-								
	EPACs shall have at least <i>C</i> clearance between the pedal and front tyre or mudguard (when turned to any position). The clearance shall be measured forward and parallel to the longitudinal axis of EPAC from the centre of either pedal-axle to the arc swept by the tyre or mudguard, whichever results in the least clearance (see Figure 37). The values are given in Table 27.			P								
<p style="text-align: center;">Table 27 — The values of toe clearance</p> <p style="text-align: right;">Dimensions in millimetres</p> <table border="1" style="margin-left: auto; margin-right: auto;"> <tr> <td rowspan="2" style="padding: 5px;">Toe clearance <i>C</i></td> <td style="padding: 5px;">without foot retention</td> <td style="padding: 5px; text-align: center;">100</td> </tr> <tr> <td style="padding: 5px;">with foot retention</td> <td style="padding: 5px; text-align: center;">89</td> </tr> <tr> <td colspan="3" style="padding: 5px;">NOTE Foot retention system, e.g. quick-release pedal or toe-clip.</td> </tr> </table>					Toe clearance <i>C</i>	without foot retention	100	with foot retention	89	NOTE Foot retention system, e.g. quick-release pedal or toe-clip.		
Toe clearance <i>C</i>	without foot retention	100										
	with foot retention	89										
NOTE Foot retention system, e.g. quick-release pedal or toe-clip.												

EN 15194

Clause	Requirement	Test	Result – Remark	Verdict
--------	-------------	------	-----------------	---------

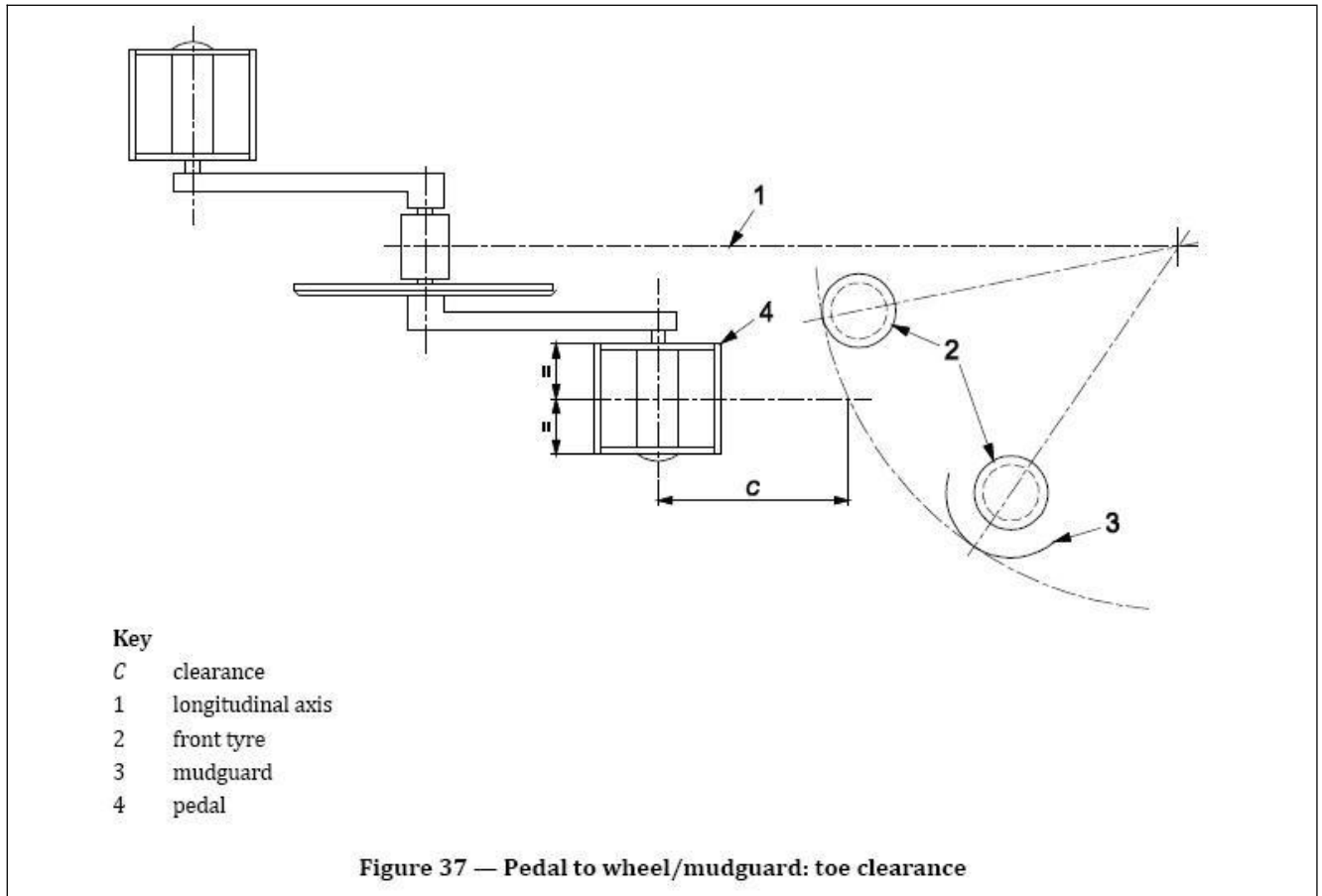
Figure 37 — Pedal to wheel/mudguard: toe clearance

4.3.12.3	Pedal – Static strength test		-
4.3.12.3.1	Requirement		-
	When tested by the method described in 4.3.12.3.2, there shall be no fractures, visible cracks, or distortion of the pedal or spindle that could affect the operation of the pedal and pedal-spindle.		P
4.3.12.4	Pedal – Impact test		-
4.3.12.4.1	Requirement		-
	When tested by the method described in 4.3.12.4.2, there shall be no fractures of any part of the pedal body, the pedal-spindle or any failure of the bearing system.		P
4.3.12.5	Pedal – Dynamic durability test		-
4.3.12.5.1	Requirement		-
	When tested by the method described in 4.3.12.5.2, there shall be no fractures or visible cracking of any part of the pedal, the pedal-spindle nor any failure of the bearing system.		P
4.3.12.6	Drive-system – Static strength test		-
4.3.12.6.1	Requirement		-
	a) Drive-system with chain When tested by the method described in 4.3.12.6.2, there shall be no fracture of any component of the drive system, and drive capability shall not be lost.		P

EN 15194				
Clause	Requirement	Test	Result – Remark	Verdict
	b)	Drive-system with belt. When tested by the method described in 4.3.12.6.3, there shall be no fracture of any component of the drive system, and the belt shall not slip/skip, fracture or cause any loss in drive capability. Smooth sliding between pulleys and belt is allowed at a rate not exceeding 1 °/s at the drive axis.		
4.3.12.6.2	Test method for drive-system with chain			-
4.3.12.6.2.1	General			-
	Conduct the drive system static load test on an assembly comprising the frame, pedals, transmission system, rear wheel assembly, and, if appropriate, the gear-change mechanism. Support the frame with the central plane vertical and with the rear wheel held at the rim to prevent the wheel rotating.			P
4.3.12.6.2.2	Single-speed system			-
	With the left-hand crank in the forward position, apply a force, <i>F</i> ₁₅ , increasing gradually to 1 500 N vertically downwards to the centre of the left-hand pedal. Maintain this force for 1 min. Should the system slip or the drive-sprockets tighten such that the crank rotates while under load to a position more than 30° below the horizontal, remove the test force, return the crank to the horizontal position or some appropriate position above the horizontal to take account of yield or movement and repeat the test. On completion of the test on the left-hand crank repeat the test with the right-hand crank in the forward position and with the force applied to the right-hand pedal.			P
4.3.12.6.2.3	Multi-speed system			-
	a) Conduct the tests described in 4.3.12.6.2.2 with the transmission correctly adjusted in its highest gear; b) Conduct the tests generally as described in 4.3.12.6.2.2 with the transmission correctly adjusted in its lowest gear but, where appropriate, with the maximum force, <i>F</i> ₁ , adjusted to suit the particular gear ratio, thus: The maximum force, <i>F</i> ₁₅ , shall be a function of the lowest gear ratio, <i>N</i> _c / <i>N</i> _s , Where 1) <i>F</i> ₁₅ is the force applied to the pedal, expressed in newton (N), 2) <i>N</i> _c is the number of teeth on the smallest chain-wheel (front), 3) <i>N</i> _s is the number of teeth on the largest sprocket (rear). Where the ratio <i>N</i> _c / <i>N</i> _s has a value equal to or greater than one, the force, <i>F</i> ₁₅ , shall be 1 500			P

EN 15194				
Clause	Requirement	Test	Result – Remark	Verdict
	N, but where the ratio N_c/N_s has a value less than one, the force, F_{15} , shall be reduced in proportion to the lowest gear ratio thus: F_{15} is $1\,500 \times N_c/N_s$			
4.3.12.7	Crank assembly – Fatigue test			-
4.3.12.7.1	Requirement			-
	When tested by the method described in 4.3.12.7.2, there shall be no fractures or visible cracks in the cranks, the bottom-bracket spindle or any of the attachment features, or loosening or detachment of the chain-wheel from the crank. For composite cranks, the running displacements (peak-to-peak values) of either crank at the point where the test forces are applied shall not increase by more than 20 % of the initial value (see 4.3.1.6).			P
4.3.13	Drive-chain and drive belt			-
4.3.13.1	Drive-chain			-
	Where a chain-drive is used as a means of transmitting the motive force, the chain shall operate over the front and rear sprockets without binding. The chain shall conform to the tensile strength and push-out force requirements of ISO 9633.			P
4.3.13.2	Drive belt			-
4.3.13.2.1	Requirement			-
	Where a belt-drive is used as a means of transmitting the motive force, the drive belt shall operate over the front and rear pulleys without binding. And when tested by the methods described in 4.3.13.2.2, there shall be no evidence of cracking, fracture or delamination of the belt drive.			P
4.3.14	Chain-wheel and belt-drive protective device			-
4.3.14.1	Requirement			-
	EPAC shall be equipped with one of the following; a) a chain wheel disc or drive pulley disk which conforms to 4.3.14.2; or b) a chain and drive belt protective device which conforms to 4.3.14.3; or c) where fitted with positive foot-retention devices on the pedals, a combined front gear-change guide which conforms to 4.3.14.4 shall be used.			P
4.3.14.2	Chain-wheel disc and drive pulley disc diameter			-
	A chain-wheel disc shall exceed the diameter of the outer chain-wheel, when measured across the tips of the teeth by not less than 10 mm (see Figure 44). A drive pulley disc shall exceed the diameter of the front pulley, when measured across the tips of the teeth by not less than 10 mm (see Figure 45). Where the design is such that the pedal-			P

EN 15194

Clause	Requirement	Test	Result – Remark	Verdict
--------	-------------	------	-----------------	---------

crank and chain-wheel are too close together to accommodate a full disc, a partial disc may be fitted which closely abuts the pedal-crank.

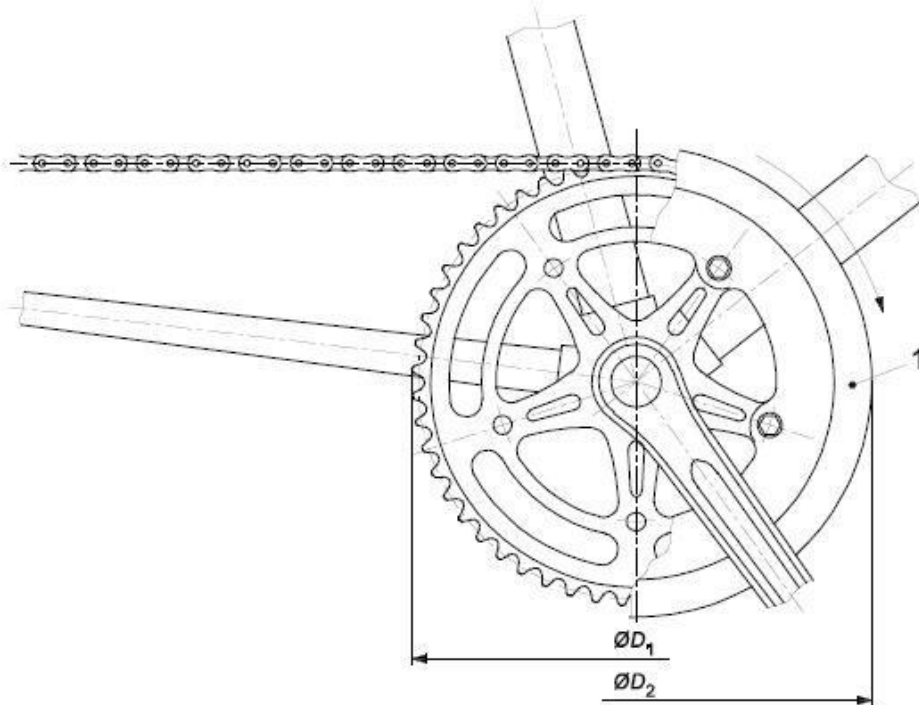

Key
 1 chain-wheel disc
 $D_2 \geq D_1 + 10$

Figure 44 — Chain-wheel disc

EN 15194

Clause	Requirement	Test	Result – Remark	Verdict
--------	-------------	------	-----------------	---------

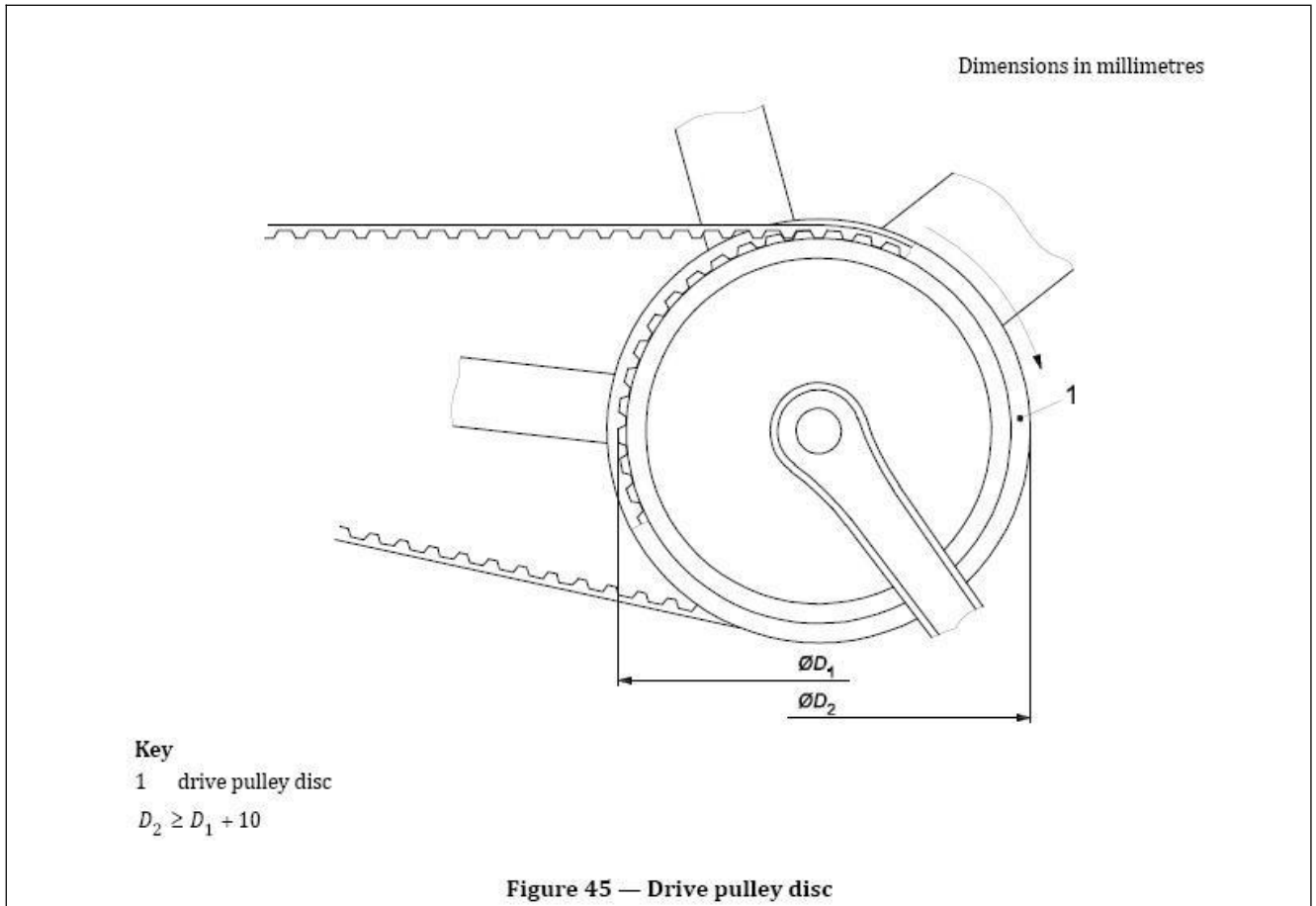

4.3.14.3	Chain and drive belt protective device			- P
	<p>A chain protective device shall, as a minimum, shield the side-plates and top surface of the chain and the chain-wheel for a distance of at least 25 mm rearwards along the chain from the point where the chain-wheel teeth first pass between the side-plates of the chain and forwards round the outer chain-wheel to a horizontal line passing through the bottom-bracket axle centre (see Figure 46 a)).</p> <p>A drive belt protective device shall, as a minimum, shield the side and top surface of the drive belt and the front pulley for a distance of at least 25 mm rearwards along the drive belt from the point where the tip circle of the pulley is intersected by the tip line of the belt (line C in Figure 46 b)) and forwards round the front pulley to a horizontal line passing through the bottom-bracket axle centre (see Figure 46 b)).</p>			

EN 15194

Clause	Requirement	Test	Result – Remark	Verdict
--------	-------------	------	-----------------	---------

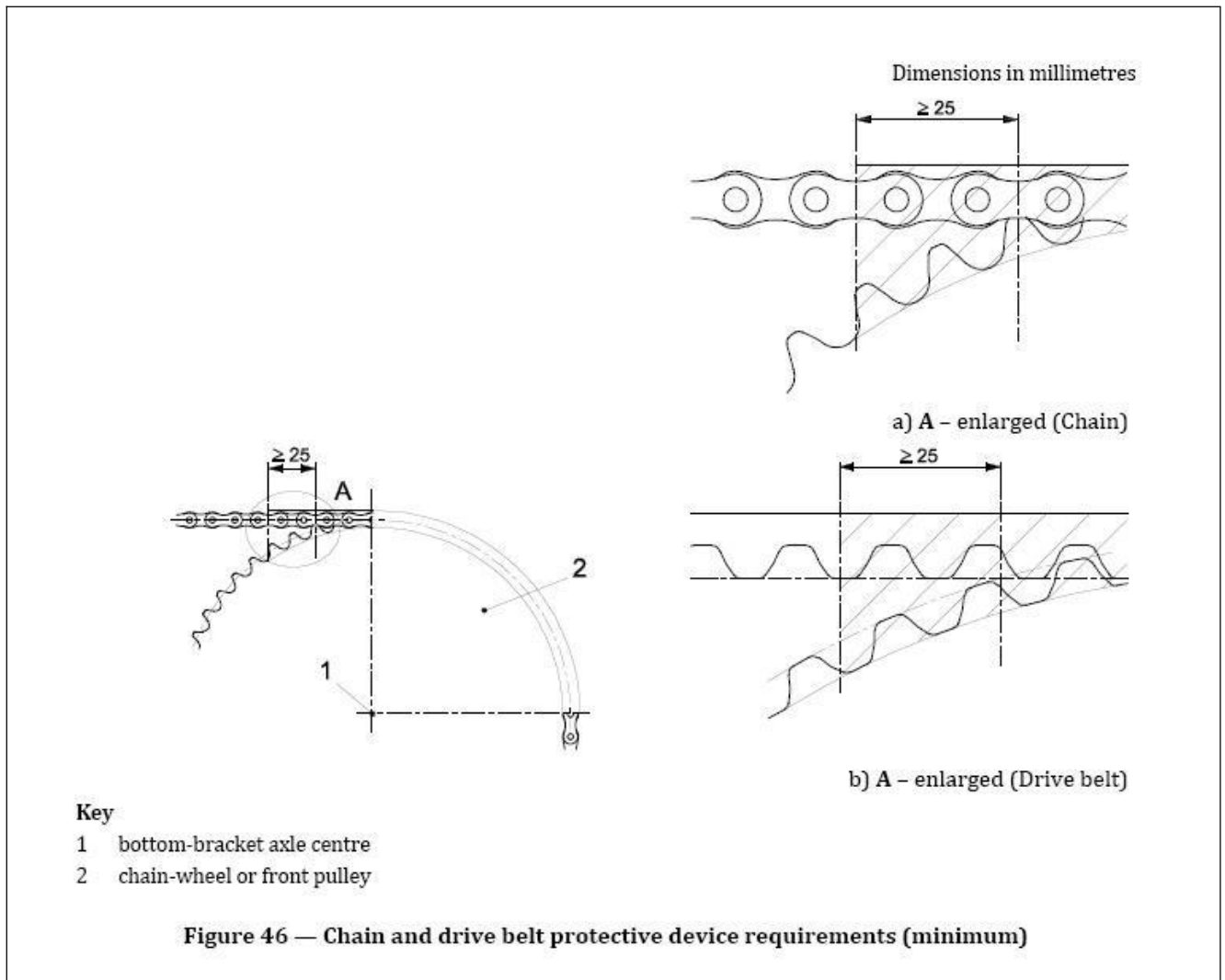

4.3.14.4	Combined front gear-change guide			- P
	<p>When the chain is located in the outer gear position, some portion of the combined front gear change guide shall be above the chain in the region 25 mm from the point where the chain wheel first passes between the side plates of the chain, parallel to the chain side plates in the direction towards the rear wheel of the bicycle (see Figure 47).</p> <p>In addition some portion of the combined front gear change guide shall be present below the chain in the region beyond 25 mm from the point where the chain wheel first passes between the side plates of the chain, parallel to the chain side plates in the direction towards the rear wheel of the bicycle (see Figure 47).</p> <p>It is recommended that the gap between front-gear and front gear-change guide specified by the manufacturer is properly set.</p>			

EN 15194

Clause	Requirement	Test	Result – Remark	Verdict
--------	-------------	------	-----------------	---------

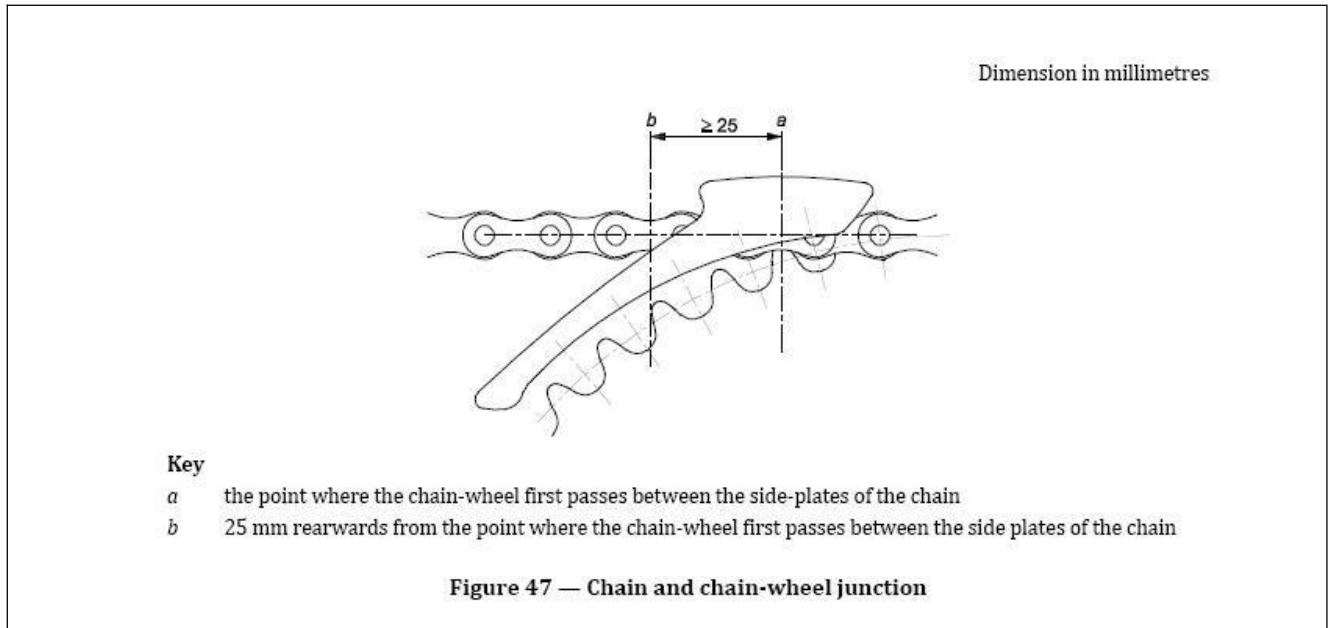

4.3.15	Saddles and seat-posts		-
4.3.15.1	Limiting dimensions		-
	No part of the saddle, saddle supports, or accessories to the saddle shall be more than 125 mm above the top saddle surface at the point where the saddle surface is intersected by the seat-post axis.		P
4.3.15.2	Seat-post – Insertion-depth mark or positive stop		-
	<p>The seat-post shall be provided with one of the two following alternative means of ensuring a safe insertion-depth into the frame:</p> <p>a) it shall contain a permanent, transverse mark of length not less than the external diameter or the major dimension of the cross-section of the seat-post that clearly indicates the minimum insertion-depth of the seat-post into the frame. For a circular cross-section, the mark shall be located not less than two diameters of the seat-post from the bottom of the seat-post (i.e. where the diameter is the external diameter). For a non-circular cross-section, the insertion-depth mark shall be located not less than 65 mm from the bottom of the seat-post (i.e. where seat-post has its full cross-section);</p> <p>b) it shall incorporate a permanent stop to prevent it from being drawn out of the frame such as to leave the insertion less than the amount specified in a) above.</p>		P
4.3.15.3	Saddle/seat-post – Safety test		-
4.3.15.3.1	General		-
	If a suspension seat-post is involved, the test may be conducted with the suspension-system either free to operate or locked. If it is locked, the pillar shall be at its maximum length.		P-

EN 15194				
Clause	Requirement	Test	Result – Remark	Verdict
4.3.15.3.2	Saddles with adjustment-clamps			-
	When tested by the method described in 4.3.15.3.4, there shall be no movement of the saddle adjustment clamp in any direction with respect to the seat-post, or of the seat-post with respect to the frame, nor any failure of saddle, adjustment clamp or seat-post. If the saddle design is such that it cannot accurately test the saddle/seat-post clamp, it shall be possible to use a fixture which is representative of the saddle dimensions.			P
4.3.15.3.3	Saddles without adjustment-clamps			-
	Saddles that are not clamped, but are designed to pivot in a vertical plane with respect to the seat-post, shall be allowed to move within the parameters of the design and shall withstand the tests described in 4.3.15.3.4 without failure of any components.			P
4.3.15.4	Saddle – Static strength test			-
4.3.15.4.1	Requirement			-
	When tested by the method described in 4.3.15.4.2, the saddle cover and/or plastic moulding shall not disengage from the chassis of the saddle, and there shall be no cracking or permanent distortion of the saddle assembly.			P
4.3.15.5	Saddle and seat-post clamp – Fatigue test			-
4.3.15.5.1	General			-
	Seat-posts can influence test failures of saddles: for this reason, a saddle shall be tested in combination with a seat-post as recommended by the saddle manufacturer.			P
4.3.15.5.2	Requirement			-
	When tested by method described in 4.3.15.5.3, there shall be no fractures or visible cracks in the seat-post or in the saddle, and no loosening of the clamp.			P
4.3.15.6	Seat-post – Fatigue test			-
4.3.15.6.1	General			-
	In the following test, if a suspension seat-post is involved, the test shall be conducted with the suspension system adjusted to give maximum resistance. Conduct the test in two stages on the same assembly as per 4.3.15.6.2 and 4.3.15.6.4.			P
4.3.15.6.2	Requirement for stage 1			-
4.3.15.6.2.1	Seat-post without suspension system			-
	When tested by the method described in 4.3.15.6.3, there shall be no visible cracks or fractures in the seat-post, nor any bolt failure. For composite seat-post, the peak deflection of seat-post during the test shall not increase by more than 20 % of the initial value.			P
4.3.15.6.2.2	Seat-post with suspension system			-
	When tested by the method described in 4.3.15.6.3, there shall be no visible cracks or			P

EN 15194				
Clause	Requirement	Test	Result – Remark	Verdict
	fractures in the seat-post, nor any bolt failure. The design shall be such that in the event of failure of the suspension system, the two main parts do not separate nor does the upper part (i.e. the part to which the saddle would be attached) become free to swivel in the lower part.			
4.3.15.6.3	Requirement for stage 2			-
4.3.15.6.3.1	Seat-post without suspension system			-
	When tested by the method described in 4.3.15.6.5, there shall be no fractures, and the displacement shall not exceed 10 mm during testing.			P-
4.3.15.6.3.2	Seat-post with suspension system			-
	When tested by the method described in 4.3.15.6.5, there shall be no fractures. The design shall be such that in the event of failure of the suspension system, the two main parts do not separate nor does the upper part (i.e. the part to which the saddle would be attached) become free to swivel in the lower part.			P
4.3.16	Spoke protector			-
	EPAC bicycles with multiple free-wheel/cassette sprockets shall be fitted with a spoke-protector guard to prevent the chain interfering with or stopping rotation of the wheel through improper adjustment or damage.			P
4.3.17	Luggage carriers			-
	If luggage carriers are fitted or provided they shall comply with EN ISO 11243.			P
4.3.18	Road-test of a fully-assembled EPAC			-
4.3.18.1	Requirements			-
	When tested by the method described in 4.3.18.2, there shall be no system or component failure and no loosening or misalignment of the saddle, handlebar, controls or reflectors. The EPAC shall with or without assistance exhibit stable handling in braking, turning and steering, and it shall be possible to ride with one hand removed from the handlebar (as when giving hand signals), without difficulty of operation or hazard to the rider.			P
4.3.19	Lighting systems and reflectors			-
4.3.19.1	General			-
	EPAC shall be equipped with reflectors at the front, rear and side. EPAC shall be equipped with lighting systems and reflectors in conformity with the national regulations in the country in which EPAC is marketed, because national regulations for lighting systems and reflectors differ from country to country.			P
4.3.19.2	Wiring harness			-
	When a wiring harness is fitted, it shall be positioned to avoid any damage by contact with moving parts or sharp edges. All connections			P

EN 15194

Clause	Requirement	Test	Result – Remark	Verdict
	shall withstand a tensile force in any direction of 10 N.			
4.3.19.3	Lighting systems			-
	The lighting system consists of a front and a rear light. These devices shall comply with the provisions in force in the country in which the product is marketed. If there are no forced provisions of these devices, the lighting system shall comply with the requirements of ISO 6742-1.			P
4.3.19.4	Reflectors			-
4.3.19.4.1	General			-
	These devices shall comply with the provisions in force in the country in which the product is marketed. If there are no forced provisions of these devices, the retro-reflective devices shall comply with the requirements of ISO 6742-2.			P
4.3.19.4.2	Rear reflectors			-
	Rear reflectors shall be red in colour.			-
4.3.19.3	Side reflectors			-
	The retro reflective device(s) shall be either a) a reflectors fitted on the front half and on the rear half of EPAC. At least one of these shall be mounted on the spokes of the wheel. Where EPAC incorporates features at the rear wheel other than the frame and mudguard stays, the moving reflector shall be mounted on the front wheel; or b) a continuous circle of reflective material applied to both sides of each wheel within 10 cm of the outer diameter of the tyre. All side reflectors shall be of the same colour, either white (clear) or yellow.			P
4.3.19.4.4	Front reflectors			-
	Front reflectors shall be white (clear) in colour.			P
4.3.19.4.5	Pedal reflectors			-
	Each pedal shall have reflectors, located on the front and rear surfaces of the pedal. The reflector elements shall be either integral with the construction of the pedal or mechanically attached, but shall be recessed from the edge of the pedal, or of the reflector housing, to prevent contact of the reflector element with a flat edge placed in contact with the edge of the pedal.			P
4.3.20	Warning device			-
	Where a bell or other suitable device is fitted, it shall comply with the provisions in force in the country in which the product is marketed.			P
4.3.21	Thermal hazards			-
	A warning shall be placed on the surface if the temperature of the hot accessible surface could be above 60 °C (see EN ISO 7010:2012, symbol W017). Brake systems are excluded from this requirement.			P
4.3.22	Performance levels (PLrs) for control system			-

EN 15194

Clause	Requirement	Test	Result – Remark	Verdict								
	of EPACs											
	<p>The safety related parts of the control systems of the EPAC shall comply with the required performance level (PLr) given in Table 34 in accordance with EN ISO 13849-1.</p> <p>Should risk assessment indicate that additional or different PLr are required for a particular application, these should be determined in accordance with EN ISO 13849 (all parts). Such PLr will be outside the scope of this standard.</p> <p>The manufacturer of the EPAC shall record the process adopted for verification of compliance with PLr for each relevant safety function.</p>			P								
Table 34 — Safety functions related to defined hazards												
<table border="1" style="width: 100%; border-collapse: collapse;"> <thead> <tr> <th style="width: 70%;">Safety function</th> <th>Performance Level</th> </tr> </thead> <tbody> <tr> <td>Prevention of an unintentional self-start of the EPAC</td> <td>PLr c</td> </tr> <tr> <td>Prevention of electric motor assistance functions without pedalling, and without activation of the start-up assistance mode</td> <td>PLr c</td> </tr> <tr> <td>Prevention of risk of fire in case of management system failure for batteries with capacity above 100 Wh</td> <td>PLr c</td> </tr> </tbody> </table>					Safety function	Performance Level	Prevention of an unintentional self-start of the EPAC	PLr c	Prevention of electric motor assistance functions without pedalling, and without activation of the start-up assistance mode	PLr c	Prevention of risk of fire in case of management system failure for batteries with capacity above 100 Wh	PLr c
Safety function	Performance Level											
Prevention of an unintentional self-start of the EPAC	PLr c											
Prevention of electric motor assistance functions without pedalling, and without activation of the start-up assistance mode	PLr c											
Prevention of risk of fire in case of management system failure for batteries with capacity above 100 Wh	PLr c											
4.4	List of significant hazards			-								
	<p>The following significant hazards have been considered in this standard:</p> <p>NOTE 1 The risk analysis was focused on EPAC as bicycles for city and trekking, including folding bicycles. Mountain bike and racing bike were not considered.</p> <p>a) Mechanical hazards: high deceleration, high acceleration, Protrusion, instability; kinetic energy; rotating elements and moving elements, rough, slippery surface, sharp edges;</p> <p>b) Electrical hazards: electromagnetic phenomena; electrostatic phenomena; overload; short-circuit; thermal radiation;</p> <p>NOTE 2 The strength of the battery holder combination should the EPAC fall to the side will be considered at the next revision.</p> <p>c) Thermal hazards: explosion; flame; radiation from heat sources;</p> <p>d) Ergonomic hazards: effort; lighting; posture;</p> <p>e) Hazards associated with the environment in which the machine is used: water (rain and projection);</p> <p>f) Combination of hazards: braking under wet and dry condition, handgrips, motor management system, engine power management, installed braking power.</p>			P								
5	Marking, labelling			-								
5.1	Requirement			P								
5.2	Durability test			-								
5.2.1	Requirement			P								
6	Instruction for use			-								

-Appendix 1: Photo document:

FIGURE 1



FIGURE 2



FIGURE 3



FIGURE 4



FIGURE 5



FIGURE 6



FIGURE 7



FIGURE 8



-----End of report-----