



PURE SINE WAVE POWER INVERTER **GENERAL USER MANUAL**



Thank you very much for purchasing our inverter. Before using the inverter, please read this manual carefully and use it correctly. After reading it, please put it in a safe place and keep it well.

Table of Contents

INTRODUCTION	1
PRODUCT SERVICE AND SUPPORT	2
1.Safety Precautions	3
1.1 Safety Instructions	3
1.2 Electrical Safety	4
1.3 Installation Safety	5
1.4 Grounding Instructions	6
2.Load Precautions	7
3.Calculation Method of Required Capacity	8
4.Product Information	12
4.1 Fuse Parameters	12
4.2 Fuse Replacement Instructions	13
4.3 Battery Cables Parameters	14
4.4 Package Contents	15
5.Components Overview	16
5.1 Panel Introduction	16
5.2 LCD Display Particulars	17
5.3 Protection Mechanisms	18
5.4 Wireless Remote Control Function	18
6.Operation Method	20
6.1 How to Connect	20
Connection on the Inverter Side	20
Connection on the Cigarette Lighter Side	21
Connection on the Battery Side	21
7.Product Specification	23
8.Troubleshooting	25
Maintenance Precautions	26

INTRODUCTION

Thank you for purchasing our Pure Sine Power Inverter. Please read this manual thoroughly before you install and set up your new power inverter.

Our Pure Sine Wave Inverter series of products is used for back-up power. The pure sine wave inverter product line is the ideal choice for sensitive equipment and provides clean power with higher efficiency for back-up power applications. Power inverters convert DC (direct current) electricity into AC (alternating current) electricity which can be used for running various tools and appliances. Pure sine wave inverter is a perfect choice for providing mobile electric power for cars, RVs, boats, and trucks. The inverter can also be utilized as a back-up power source in case of a power failure or for various off-grid applications such as camping or RVs.

NOTE:

This manual is a general manual for the pure wave inverter product line, including instructions for all basic models. Please feel free to contact us if you have any questions about the manual during use. Due to the continuous improvement of products, the content of the manual is subject to change without prior notice.



PRODUCT SERVICE AND SUPPORT

We have our own factory and can provide customers with the most professional services and the best quality products. We have a professional service team. If you have any questions about your product, you can contact us at any time and we will provide you with professional technical support.

- Professional consultation. We will answer any of your technical questions within 24 hours.
- Convenient troubleshooting. We will provide you with professional advice and guidance based on your feedback, make it easy for you to troubleshoot simple machine failures on your own.



Thank you again for purchasing our inverter!

1. Safety Precautions







Read all of the instructions and cautions in the manual before beginning the installation.

In order to make better use of inverters and prevent accidents of personal injury and property damage, please pay attention to the safety precautions and operate the inverter carefully with common sense in life.















In order to help you read this user manual and use the inverter more effectively, we explain the symbols used in this manual as follows (please read and obey the following symbols in this manual):

Symbol	Description
	The symbol indicates "prohibited operations" to ensure the safety of the product and the user.
	The symbol indicates "mandatory operations" to ensure the safety of the product and the user.
	The symbol indicates "operations that require attention" to avoid potential danger to the product and the user.

◆ 1.1 Safety Instructions

-  Please read all of the instructions and cautions in the manual before beginning the installation.
-  NEVER attempt to disassemble or repair the inverter without the guidance of a professional service team.
-  Please make sure that all the input and output terminals of the inverter are connected firmly. Sparks may occur when connecting, so make sure there are no flammable materials or gases near the installation.
-  DO NOT operate the inverter under the influence of alcohol or drugs. If you have poor judgment or responsiveness, please do not operate the inverter.
-  Individuals with pacemakers should consult with their physician(s) before using this product. Electromagnetic fields near a pacemaker may cause interference or malfunction of the pacemaker.
-  Please ensure the switch is in the off position when not in use and before plugging in any devices to avoid accidental activation.
-  DO NOT put anything other than electrical appliances into the output terminals, otherwise it may cause electric shock or fire. The power inverter will output the same AC power as utility power. Please treat the AC outlets with the same care you would treat the outlets at home.

◆ 1.2 Electrical Safety







-  NEVER connect the AC output of the unit directly to an Electrical Breaker Panel/Load Centre that also receives power from the utility/generator.
-  NEVER use the inverter with positive grounded electrical system. This unit is designed for use with negative grounded electrical systems only.
-  ALWAYS ensure the inverter is off before connecting anything.
-  When connecting battery terminals, ensure that the polarity of the battery connections is correct. Incorrect polarity may cause permanent damage to the unit.
-  ALWAYS ensure the inverter is in the OFF position and all AC and DC connections are disconnected before working on any circuit related to the inverter.
-  Be careful when touching exposed capacitor terminals as they may retain high lethal voltages even after the power is removed.
-  Sparks may occur when connected to the battery. Combustible gas will be generated during charging and discharging, so please ensure that the surrounding is well ventilated, and do not store the inverter in a place where flammable gas gathers.
-  DO NOT connect the output in parallel with the mains, otherwise it may damage the inverter and cause electric shock hazard.
-  When using this inverter, DO NOT bundle wires together and use broken wires, as this can cause electric shock, short circuits, or fires.
-  DO NOT get the body wet, otherwise it may cause short circuit, fire and electric shock.
-  DO NOT place any stick items or other metal objects at any vent or opening, as this could touch internal components and result in electric shock or injury.
-  Make sure the device is fully plugged into the electrical socket. Failure to fully insert the plug into the outlet may result in electric shock and overheating, which may result in a fire accident.
-  DO NOT use a damaged plug or loose socket. DO NOT touch the machine with wet hands, otherwise it may cause electric shock.
-  KEEP AWAY FROM FIRE. DO NOT let volatile substances or combustible substances float into the machine. Please keep the machine away from fire
-  DO NOT damage the output sockets or wires. DO NOT cut, modify, heat, over-distort, twist or pull the cable, and keep the cable and receptacle it from being subjected to heavy pressure, as this may result in an electrical dangerous such as electric shock, fire or short circuit.

◆ 1.3 Installation Safety

Placement Requirements:

Make sure there is enough space and follow the user manual for installation.

Installation Area Requirements:

-  Dry - Keep the inverter away from liquids, it should be placed in a completely dry location.
-  Cool - Inverters should be installed in an area where the fans are unobstructed, and away from direct sunlight and heat sources. The ambient temperature range should be 0-40°C (10-25° C is preferred).
-  Vented - Allow at least 15-25cm of clearance around the inverter to allow adequate airflow, make sure the vents at the ends of the unit are not blocked.
-  Fire Hazard Protection - Do not install the inverter in the same compartment with the battery or in any compartment that could contact flammable liquids, and avoid installing it in locations where the fire protection equipment is required.
-  Near the battery bank - Install the inverter as close as possible to the battery bank and connect the inverter to the battery by using the battery cables in the package. It is better and cheaper to use longer AC power cables. Excessive battery cable lengths can cause voltage drop.
-  Low-dust - Avoid installing the inverter in an area with dust, wood debris, or other particles that may enter the inverter and increase its internal temperature.
-  Maintain Cleanliness - Ensure that the machine and its surrounding environment are kept clean to avoid damage from cockroaches or other insects.

RECOMMENDATIONS:

Our inverter should be placed horizontally. Mount the inverter on a stable surface, such as a floor, table, or sturdy support, to prevent bouncing and movement. Choose a location that can support the weight of the inverter. It's best to use four screws to fix the product in place.

SPECIAL NOTES FOR CHILDREN:



Never allow children to operate or play with the inverter.



Keep the unit away from children. Choose to install the inverter out of the reach of children.



Keep all accessories out of the reach of children as they could be dangerous.

◆ 1.4 Grounding Instructions

- The yellow-green short cable is the ground wire. Our pure sine wave inverters are equipped with a ground terminal that can be properly grounded or connected to another designated ground point.

- The grounding connection must be securely tightly connected to bare metal. Grounding is strongly recommended when using the inverter in mobile applications such as RVs or in buildings.

- For more information on grounding, it is recommended to reference Local and National Electrical Codes (NEC) for specific grounding regulations and recommendations, as they may vary depending on the circumstances.

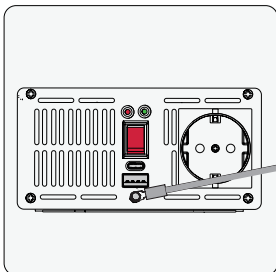

- The ground wire should be properly connected to the grounding system or grid. The ground wire is usually connected to the grounding electrode, earth electrode, or grounding device of a building. When wiring, make sure the ground wire is properly grounded to the metal casing or conductor of other electrical equipment.

2. Load Precautions



Note: If you encounter any situation where certain loads cannot be used when using the inverter, please contact us, and we will do our best to solve the problem for you.

The rated power consumption and maximum power consumption of the following devices vary significantly. Please confirm that the maximum power consumption of the equipment you are using is within the maximum output capacity of this product, based on the following guidelines. Even for devices with the same rated power consumption, the maximum power consumption may vary depending on the manufacturer and model structure, and there may be cases where it cannot be used. If you are not sure about the power consumption, please contact us.

For lighting equipment [fluorescent lamps]: Consider the power consumption of the fluorescent tube and the power consumption of the fixture (power source unit).

Example: In the case of lighting equipment that uses a 20W fluorescent lamp and has a rated power consumption of 15W for the fixture, the guideline for maximum power consumption is 35W or higher in total.

If the rated power consumption of the fixture (power source unit) is unknown, the criterion of more than twice the rated power consumption of the fluorescent tube will be used as the guideline for maximum power consumption.

Example: For a lighting fixture using five 30W fluorescent tubes, the maximum power consumption guideline is 300W or higher, which is twice the total power consumption of 150W.

For equipment using motors: The maximum power consumption index of equipment using motors such as refrigerators, vacuum cleaners, washing machines, electric tools, pumps and compressors is about 3 to 8 times the rated power consumption. It mostly depends on the load you use.

Microwave oven: It is expressed as 500W, 600W, 1000W, etc., but this indicates the ability to heat food which is called harmonic output power.

Please check the rated power consumption stated on the side or back of the device and in the instruction manual, and use around 2 to 4 times that value as the guideline for the maximum power consumption.

If the required power consumption exceeds the output capability of the inverter, the device cannot be used. Please confirm that the rated power consumption of the equipment you intend to use is within the rated output capability of this product, according to the following guidelines: The rated power consumption may be stated in the specifications column of the instruction manual of the equipment you intend to use and on the back of the product.

3. Calculation Method of Required Capacity

The battery is the power source for the inverter, providing DC input voltage. To ensure the inverter works properly, make sure that the rated voltage of the battery matches the rated input voltage of the inverter. Keep in mind that small-capacity batteries may not be enough to power large appliances. In this case, the load of the appliance may cause the inverter to enter undervoltage protection mode.

The rated power of the inverter is a key factor in determining the available capacity for electrical appliances. Before purchasing an inverter, we recommend confirming the total wattage of the appliances that would normally be connected. It's best to choose an inverter that is larger than the total wattage of the appliances being used. In addition, special equipment such as pumps, refrigerators and air conditioners can have a start-up load of up to eight times the rated power.

To calculate the parameters required for the battery and inverter, you will need to determine the following information:

1. Total Load Power

If the power rating is in amps, multiply this number by the AC mains voltage to get an estimate for wattage.

(For example, if the kettle draws 5 amps and the AC mains voltage is 120 volts, the rated power will be $5 \text{ amps} \times 120 \text{ volts} = 600 \text{ watts}$)

2. Inverter Efficiency

Our inverters have a maximum efficiency of 94% but typically run around 90%. You may use an efficiency rate of 90% as an estimate.

3. Estimated Load Runtime

Battery capacity depends on load power and run time. But since the load is not constant, it is crucial to estimate the expected runtime of the load.

4. Battery Voltage

Please select the battery voltage that matches the rated input voltage of the inverter.

Please refer to the formulas below to calculate your battery and inverter needs:

Formula to Calculate Required Inverter Wattage:

$$\text{Total Load Power (W) / Inverter Efficiency} = \text{Inverter Wattage}$$

(If the sensitive equipment is included in the devices that you connected to the inverter, the starting power of it may need to be increased by 3 to 8 times depending on the different situation. Note: It is recommended that the wattage of the inverter you purchase be higher than the calculated wattage.)

Formula to Calculate Required Battery Capacity:

$$\text{Total Load Power / Inverter Efficiency} * \text{Operating Time} / \text{Battery Voltage} = \text{Battery Capacity (AH)}$$

Formula to Calculate Battery Run Time (with Battery Capacity Known):

$$\text{Battery Capacity (AH)} * \text{Battery Voltage} / (\text{Total Load Power} / \text{Inverter Efficiency}) = \text{Battery Run Time}$$

Formula to Calculate the No-load Power Consumption of an Inverter:

$$\text{Inverter Input Voltage} * 0.64A = \text{Power Consumption at No Load}$$

● Simple Example Reference

Example 1:

Load: Lighting 20W + Laptop 100W + Smartphone Charging 6W + Coffee Maker 800W

Runtime: 2 hours

Battery voltage: 12VDC

Inverter efficiency: 90%

▶ Calculation Method:

Inverter Power	$(20+100+6+800*4) / 90\% \approx 3696W$  NOTE: The coffee maker belongs to electrical appliances with a motor, which requires at least 4 times the starting power.
Battery Capacity	$(20+100+6+800*4) / 90\% * 2 / 12 = 619AH$

Summary:

- According to the above required load, an inverter of about 4000W is required.
- When using the required load for 2 hours, you should choose a battery with a capacity of at least 619AH.

Example 2:

Load: Lighting 20W + Laptop 100W + Smartphone Charging 6W + Kettle 500W

Runtime: 2 hours

Battery capacity: 330AH

Inverter efficiency: 90%

Inverter voltage: 12VDC

▶ Calculation Method:

Battery Runtime	$330 * 12 / ((20 + 100 + 6 + 500) / 90\%) \approx 5.69H$
Power Consumption at No Load	$12 * 0.64A = 7.68W$

Summary:

When using a battery with a capacity of 330AH, the load can be used for around 5.69 hours, and the no-load power consumption is 7.68W.

⚠ NOTE:

- The above content is for reference only. The actual number and capacity of batteries required may vary due to factors such as inverter rated power, load power, battery capacity, and charge-discharge ratio.
- In addition, the required capacity of the batteries also depends on whether the batteries can withstand repeated charge/discharge cycle tests.

4.Product Information

The output waveform of this inverter is pure sine wave, which has the same high-quality as the power provided by utility and/or domestic power sources. This type of waveform is ideal for most electrical devices, appliances, and tools. The pure sine wave output of this inverter also provides more capabilities than modified sine wave inverters because it is a cleaner form of power. In addition, using pure sine wave reduces the amount of noise produced by appliances when it is working.

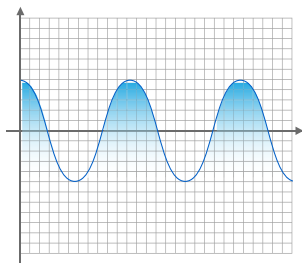

◆ 4.1 Fuse Parameters

Specification	12V	24V	48V	Quantity
1000W	40A32V	20A32V	10A32V	2
1500W	40A32V	20A32V	10A32V	3
2000W	40A32V	20A32V	10A32V	3
2500W	40A32V	20A32V	10A32V	4
3000W	40A32V	20A32V	10A32V	5

◆ 4.2 Fuse Replacement Instructions

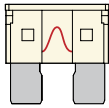

Intact Fuse

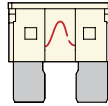

Burnt Fuse

Step 1

Disassemble (Remove) the inverter case.

(In order to avoid improper operation resulting in artificial damage to the inverter, it is recommended to contact the official email address to get the disassembly video.)

Step 2

Use a tool to pull out the fuse and check them in turn. Since there may be more than one fuse inside, it is recommended to pull out each fuse and check it. (NOTE: The internal structure of the inverter varies for each power, please check the location of the fuse carefully.)

Step 3

Replace all damaged fuses with new ones and insert them.

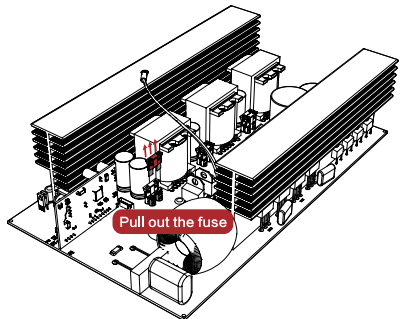
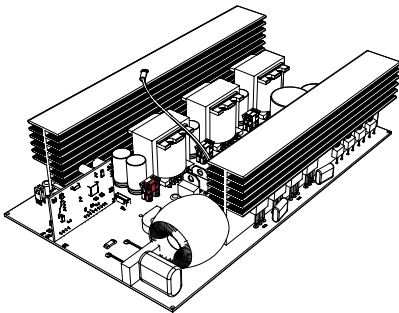

⚠ NOTE:

If you need to perform this operation, please contact us in advance. Our customer service team will provide professional guidance and operation videos.

◆ 4.3 Battery Cables Parameters

Specification	Cross-sectional area (mm ²)	Outer diameter (mm)	AWG	Length
1000W/12V	16	3.57	6	50cm
1500W/12V	16	4.51	5	
2000W/12V	25	5.64	3	
2000W/24V	16	4.51	5	
2500W/12V	35	6.67	2	
2500W/24V	20(10*2)	5.05	4	
3000W/12V	35	6.67	2	
3000W/24V	20(10*2)	5.05	4	

Above are battery cable specifications that match their respective wattage inverters. If there is any problem with the battery cable in the package, please feel free to contact us.

NOTE:

- In practice, a thick battery cable can be replaced by two thin battery cable as long as the total section area of the battery cables meets the requirements.
- The cable needs to be thick enough to carry the current. Otherwise, the battery cable with small cross-sections could cause a voltage drop that prevents the inverter from supplying large loads.
- When the input current of the power supply is large, the input battery cable may have a voltage drop. The actual working voltage depends on the measured value of the input terminal of the inverter. If the voltage drop is too much, it may be necessary to increase the cross sectional area or reduce the length of the battery cable.

◆ 4.4 Package Contents

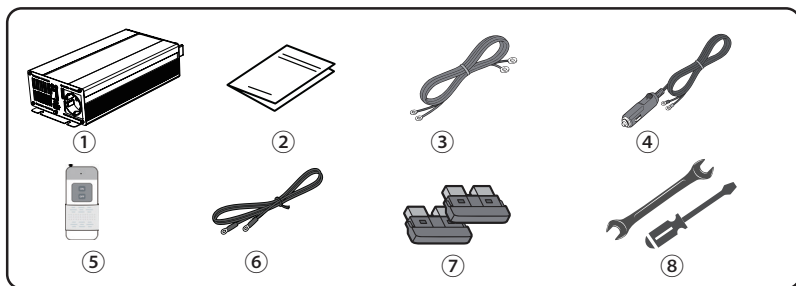

Serial Number	Accessories	Note
①	Power Inverter	<ul style="list-style-type: none"> ● The accessories that come with the inverter vary according to its power wattage. If you find that the accessories are missing or different from those shown in the accessories table after receiving the goods, please contact us. ● The 1000W inverter comes with all accessories listed in the accessories table. For other power ratings, all listed accessories are included except the cigarette lighter cable. ● Specifically, the 1000W and 1500W inverters include a screwdriver. The 2000W and 3000W inverters include a wrench. ● The wireless remote controller is included with all power rated inverters but batteries are not included. Users need to purchase a 23A battery separately to operate the remote controller.
②	General User Manual	
③	Battery Cables (0.5m)	
④	Cigarette Lighter Cable (1m)	
⑤	Wireless Remote Control	
⑥	Earth Wire (0.5m)	
⑦	Fuse	
⑧	Wrench/ Screwdriver	

5.Components Overview

◆ 5.1 Panel Introduction

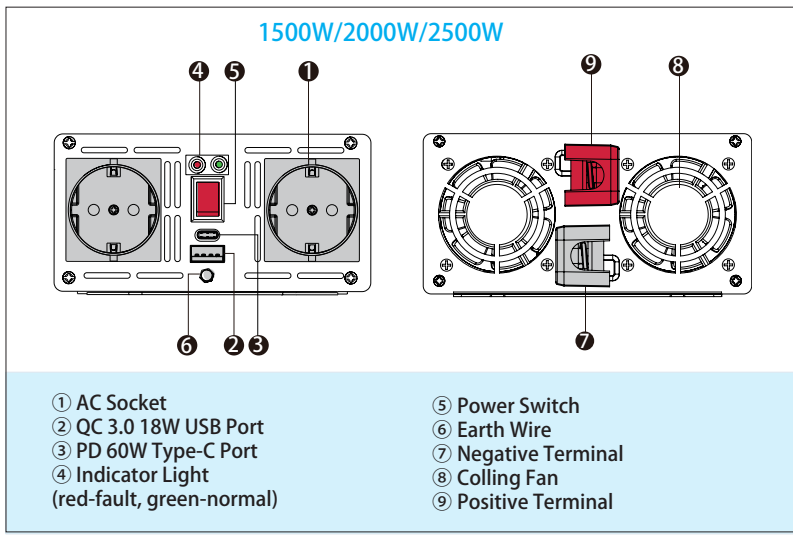
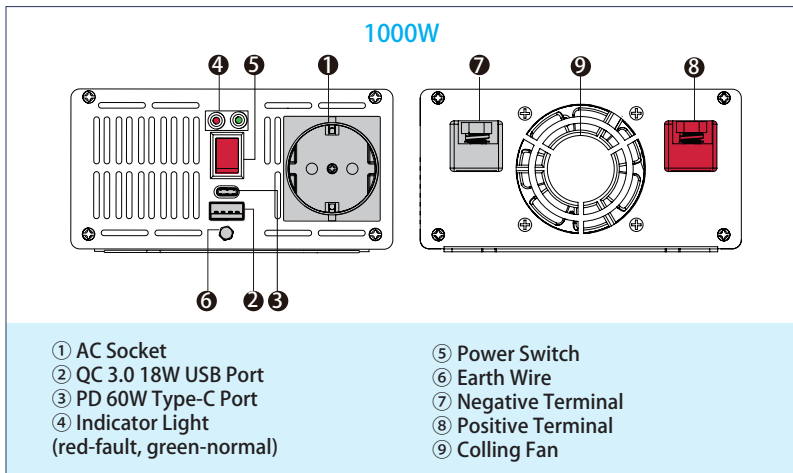

◆ 5.3 Protection Mechanisms

SOFT START TECHNOLOGY

Our inverters feature soft-start technology designed to protect equipment from supplying too much AC power at the same time. The soft-start feature gradually increases the output AC voltage, which is especially important for equipment with inductive loads or electric motors.

SIX PROTECTIONS



Protection Instructions

① **Low Voltage Input Protection:**

When the inverter is connected to low voltage, it will stop running.

② **High Voltage Input Protection:**

When an abnormally high voltage is detected at the input of the inverter, it will stop running.

③ **Over Load Protection:**

If the equipment connected to the inverter requires an output power exceeding the maximum power capacity of this product, it will stop running.

④ **Short Circuit Protection:**

When there is a short circuit at the output of the inverter, it will stop running.

⑤ **Over Temperature Protection:**

When the internal temperature of the inverter reaches a certain critical value, it will stop running.

⑥ **Battery Low/over Voltage Protection:**

When the battery voltage is too low or too high, the inverter will stop running to protect the battery.

⑦ **Low Battery Power Protection:**

When the battery power is low, the inverter will stop running.

Protection Mechanism Current & Voltage Range Table

Input Voltage	12VDC	24VDC	48VDC
Input Voltage Range	9.5V-15.5V	20V-31.5V	40V-60V
Undervoltage Alarm Value	$10.5 \pm 0.3V$	$21 \pm 0.3V$	$41 \pm 0.5V$
Undervoltage Protection Value	$9.5 \pm 0.3V$	$20 \pm 0.3V$	$40 \pm 0.5V$
Undervoltage Recovery Value	$12 \pm 0.3V$	$24 \pm 0.3V$	$48 \pm 0.5V$
Overvoltage Protection Value	$15.5 \pm 0.3V$	$31.5 \pm 0.3V$	$61 \pm 0.5V$
Overvoltage Recovery Value	$15 \pm 0.3V$	$30 \pm 0.3V$	$60 \pm 0.5V$

◆ 5.4 Wireless Remote Control Function

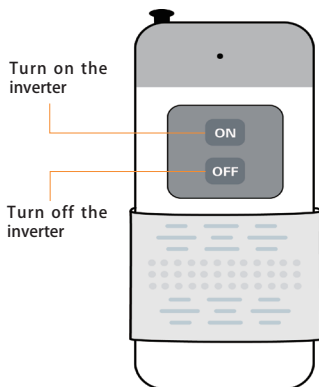

⚠ Wireless Remote Controller Instructions:

- The included wireless remote controller does not come with batteries. Please purchase a 23A battery separately to operate the remote controller. Be sure to install the battery correctly before use.
- Due to possible electromagnetic interference, there may be slight delays in the remote controller's responses during use.
- If the remote controller cannot be operated as normal, please contact us. We will provide instructions to reset the remote controller.

6.Operation Method

! CAUTION

- Before connecting any electronic equipment, please make sure that the power switches of the inverter and the connected equipment are turned OFF.
- When shutting down the inverter, be sure to disconnect all connected electronic devices first. To ensure the safety of electricity use, it is recommended to modify the circuit or maintain the inverter under the condition of complete power failure.

◆ 6.1How to Connect

● Connection on the Inverter Side

1. Remove the terminal cover from the main unit.

2. Attach the power input cord to the power input terminal with the attachment bolt. Connect the round terminal of the power input cord (red) to the power input terminal (red) of this product. Connect the round terminal of the power input cord (black) to the power input terminal (black) of this product.

3. After securing the power input cord to the power input terminal, attach the terminal cover to the main unit.

4. After completing and confirming the connection on the product side, connect the round terminal on the opposite side to the battery in the order of the [+] terminal and [-] terminal.

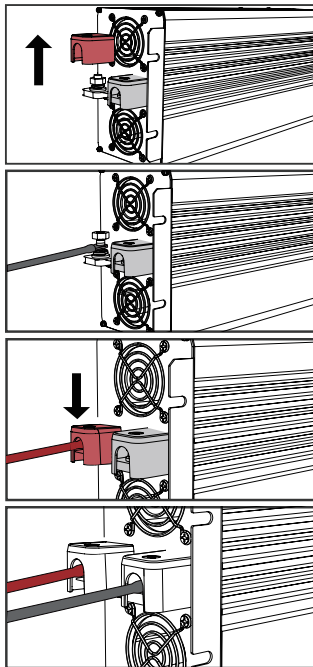

! NOTE:

The inverter is equipped with a reverse connection protection feature, which freezes the output in case of a reversed connection. However, in case of such an incident, irreversible damage to the unit may occur, and it will affect the warranty.

● Connection on the Cigarette Lighter Side

Insert the cigarette lighter plug of this product into the cigarette lighter socket of the vehicle, and the power will be turned on automatically. For most typical cars, the maximum available power is about 100W to 150W.

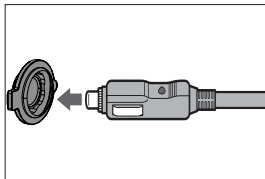

NOTE: If you use an output that exceeds the allowable range, the fuse on one side of the car may blow. Please always check before use.

Connection on the Battery Side

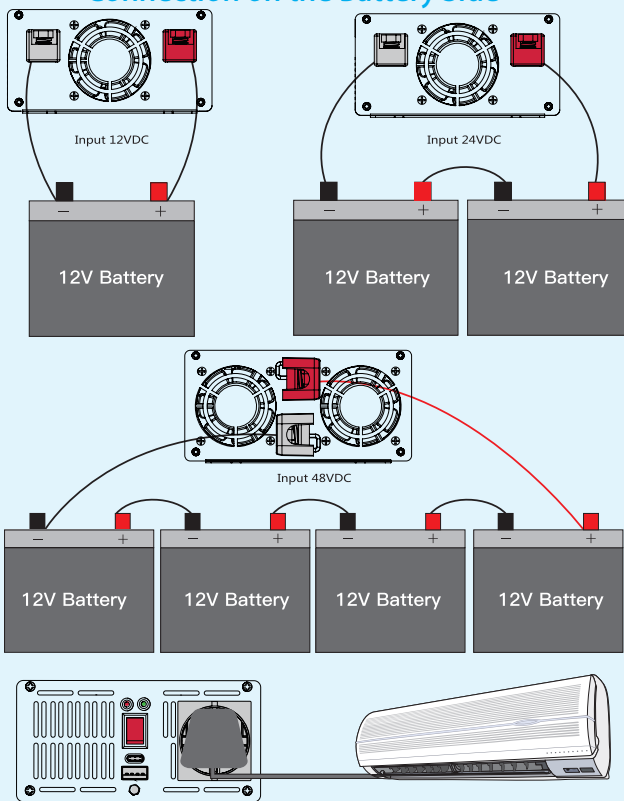

 **CAUTION**

The battery provides DC input voltage to the inverter, and its rated voltage should match the rated input voltage of the inverter. Any voltage exceeding the inverter input voltage range may cause inverter overload or damage.

In addition to voltage, the capacity of the battery (measured in amp-hours) should match the power consumption of the load. Overload or undervoltage may cause system failure or equipment failure.

Where high-power electrical equipment exceeds the limit of AC outlets, connect the equipment to the hard-wired terminal, and ensure that the ground terminal of the inverter is safely connected to the ground terminal of the equipment.

1. The inverter can use one or more batteries, but it is recommended to use a battery with a capacity of 150AH or more.
2. Connect the inverter and battery with the included cables. Make sure all cables are securely connected. Improper connections may cause the cable to overheat or the terminals to break, reducing battery life.
3. When the power switch is turned on, if the green LED lights up continuously, the inverter and fully charged battery are properly connected. It works fine under load.
4. If the red LED light is on, it means that the inverter has automatically entered protection mode.
Please check whether the battery voltage is too high or too low, or whether the inverter output is overloaded or short-circuited by checking the fault status displayed on the LCD.
The cause of the malfunction can be confirmed by the malfunction code displayed on the LCD. If you have any questions, please feel free to contact us.
5. If you want to use a home appliance continuously, you can get a longer power supply time by using one or more 12V batteries in parallel and using the AC power of the 12V inverter.
6. This product has 12V, 24V, and 48V types. Make sure you use the correct type you purchased.
7. The battery types applicable to this inverter include AGM, GEL, lithium-ion, SLD, EFB, FLD, etc.

7.Product Specification

Model Number	1000 12/24/48			1500 12/24/48			2000 12/24/48			2500 12/24/48			3000 12/24/48		
Rated Power	1000W			1500W			2000W			2500W			3000W		
Peak Power	2000W			3000W			4000W			5000W			6000W		
Input Voltage	12V	24V	48V	12V	24V	48V	12V	24V	48V	12V	24V	48V	12V	24V	48V
No-load Current (<)	0.5A	0.3A	0.15A	0.6A	0.3A	0.2A	0.6A	0.3A	0.2A	0.8A	0.4A	0.2A	0.9A	0.5A	0.3A
Output Voltage	110VAC±5%														
USB Output	QC3.0 18W (5V3.4A,9V2A,12V1.5A)														
Type-C Output	PD30W (5V3A,9V3A,12V2.5A,15V2A,20V1.5A)														
Output Socket(s)	15A*2			15A*2			15A*4			15A*4			15A*4		
Frequency	50HZ±1HZ														
Output Waveform	Pure Sine Wave														
Soft Start	✓														
Waveform Distortion	THD < 5%														
Output Efficiency	Maximum 94%														
Cooling Method	Intelligent Cooling Fan														
Fan Start-up Condition	Fan starts running when the temperature reaches 122 °F, or when the load exceeds 50%.														
Protection Function(s)	Battery under-voltage protection, over-voltage protection, output overload protection, over-temperature protection, short-circuit protection, reverse polarity protection														
Operating Temperature	(-13° F — +140° F)														
Storage Temperature	(-22° F — +158° F)														
Humidity	Maximum humidity is 90%, no condensation occurs														
Warranty	1 Year														
Product Dimension (cm)	28.2*14.4*7.3			31.2*14.4*7.3			33.7*16.3*8.1			37.7*16.3*8.1			37.7*16.3*8.1		
Net Weight (kg)	1.95			2.15			3.2			4.2			4.3		

8.Troubleshooting

Troubleshooting

Error Meaning	Reason	Solution	Protection Buzz Sound
Battery Undervoltage	Battery input voltage too low	Charge or replace the battery	Ring four times, pause for two seconds
Battery Overvoltage	Battery input voltage too high	Check if the input power source or power charger is functioning properly	Ring three times, pause for two seconds
Output Short Circuit	Output short circuit	Check the circuit and load of the output	Ring one times, pause for two seconds
Output Overcurrent	Output current is too large, instantaneous protection	Reduce the load	Ring two times, pause for two seconds
Output Overload	Output current is higher than the rated power, delay protection	Reduce the load	
Over-Temperature Protection	Over Temperature	Check the fan or air duct, and lower the ambient temperature	Ring five times, pause for two seconds
Alarm Before Protection	1).Over-temperature alarm: 1 buzz each 3 seconds 2).Over-load alarm: 1 buzz each 7 seconds 3).Over-voltage alarm: 1 buzz each 15 seconds		

Maintenance Precautions

We have our own factory and can provide customers with the most professional services and the best quality products.

We have a professional service team. If you have any questions about your product, you can contact us at any time and we will provide you with professional technical support.

If we do not respond to you promptly, it is possible that we are on vacation or that the issue may take some time to resolve. We hope you can understand.

Regarding this Manual:

- Due to the continuous improvement of products, the content of the manual are subject to change without prior notice.
- If you find any spelling errors or poor sentence structure while reading this manual, or if you find any incorrect operations or inaccurate information while using this manual, please feel free to provide feedback.
- This manual is a general manual for the pure wave inverter series products, including instructions for all basic models. Please feel free to contact us if you have any questions about the manual during use.

User information

Name:		Purchase date:	
Tel:		Address:	

Distributor/Sell name:	
Product Model:	

Distributor:

Date:

ENA Ltd (LLC)
Batalionów Chłopskich St.
83-031 Pruszcz Gdański, Poland
Tel.: (+48-58) 300 96 00
e-mail: sklep@enatruck.pl
