

KOMODA 8S

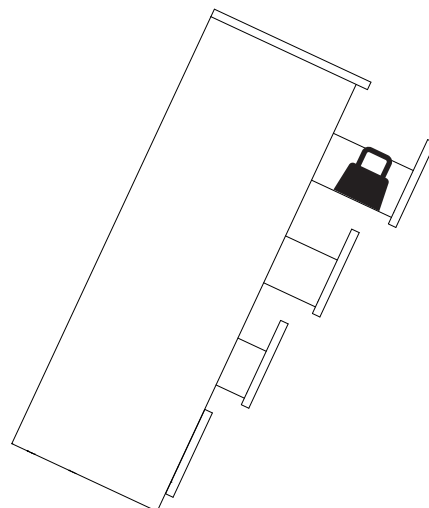

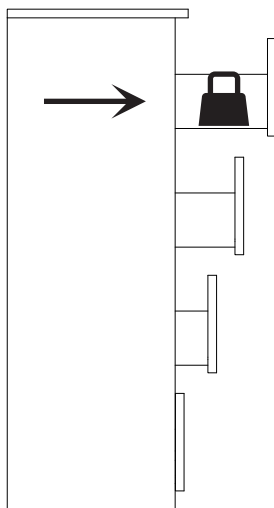
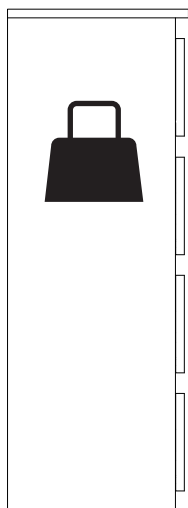

ENGLISH

WARNING

- Secure this furniture to the wall using included tip-over restraints
- Place heaviest items in the bottom drawers.
- Do not stand on the furniture
- Do not let children climb or hang on furniture.
- Do not place TV's and other heavy objects on the top of this product.

DEUTSCH

ACHTUNG

- Befestigen Sie das Möbelstück mit dem mitgelieferten Kit an der Wand
- Laden Sie die schwersten Gegenstände in die unteren Schubladen
- Treten Sie nicht auf die Möbel
- Lassen Sie Kinder nicht auf Möbel klettern oder sich daran hängen
- Stellen Sie den Fernseher und andere schwere Gegenstände nicht auf das Produkt.

POLSKI

UWAGA

- Przymocuj mebel do ściany używając dołączonego zestawu.
- Najcięższe elementy umieszczaj w dolnych szufladach.
- Nie pozwalaj dzieciom wspinać się na meble.
- Nie umieszczaj telewizora i innych ciężkich przedmiotów na górze mebla.



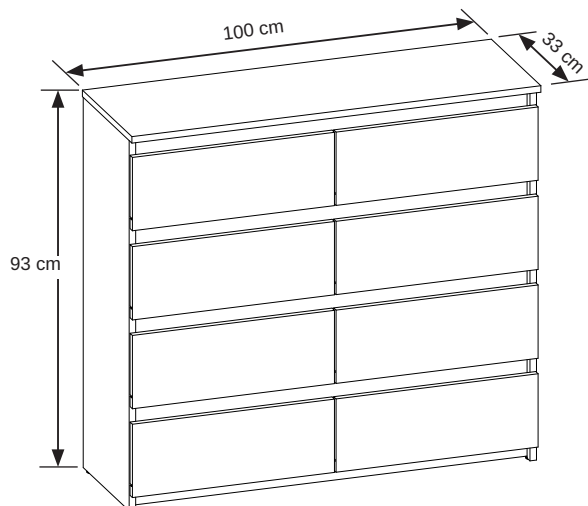



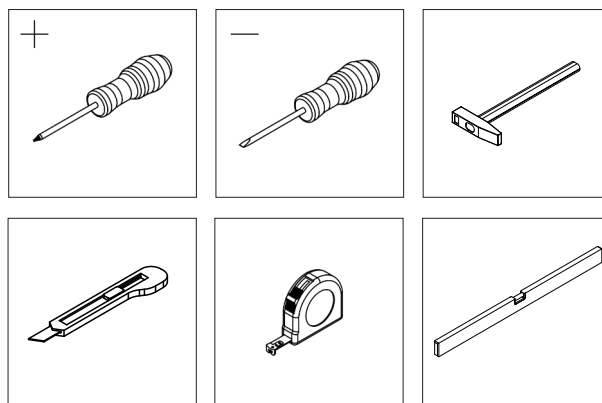





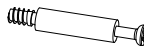

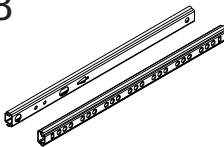







POTRZEBNE NARZĘDZIA

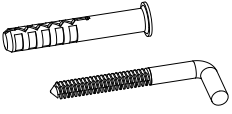

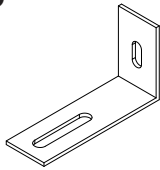
OKUCIA ZNAJDUJĄCE SIĘ W OPAKOWANIACH

M3  Ø15 10x	E1  22x	M6  Ø12 16x	N2  26x
F2  34x	L2  12x	J8  8x	S0c  3x20 73x
T1  5x	M2  10x	K2  1x	D15  8x
Z2  5x	P1  M4X9 16x	D17  8x	P9  4x16 9x
K1  1x	Z1  12x	D16  1x	S3  5x9 32x
F10  34x			

ELEMENTY ZNAJDUJĄCE SIĘ W OPAKOWANIACH

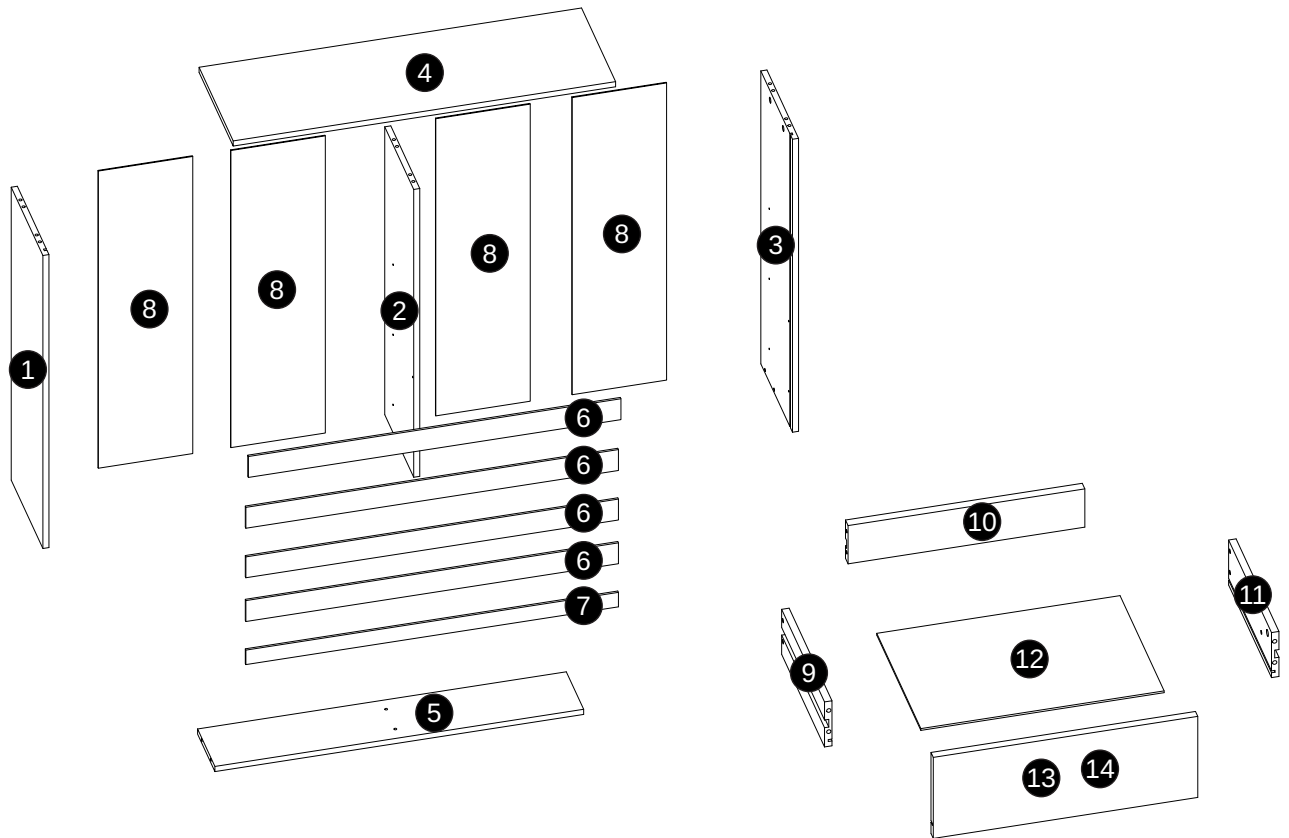

ELEMENTY ZNAJDUJĄCE SIĘ W OPAKOWANIACH

1	1x - 911x310x16mm	8	4x - 924x248x3mm
2	1x - 894x284x16mm	9	8x - 300x100x12mm
3	1x - 911x310x16mm	10	8x - 444x85x12mm
4	1x - 1004x335x16mm	11	8x - 300x100x12mm
5	1x - 968x170x16mm	12	8x - 463x299x3mm
6	4x - 978x65x6mm	13	4x - 496x180x16mm
7	1x - 978x45x6mm	14	4x - 496x180x16mm

Sposób montażu trzpienia (N2) i mimośrodowego (M3)

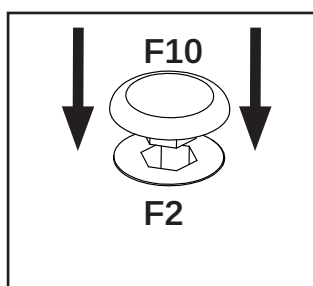
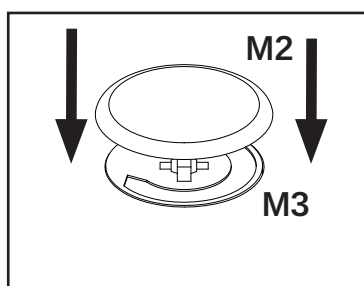
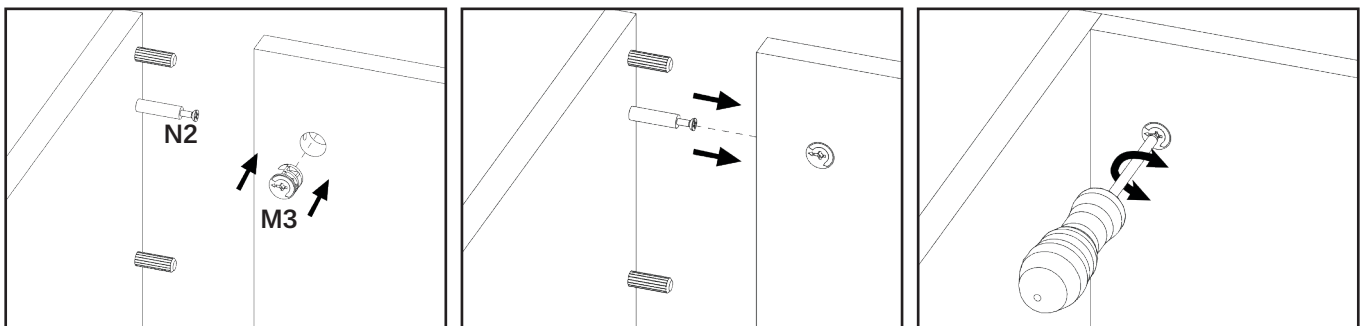

1

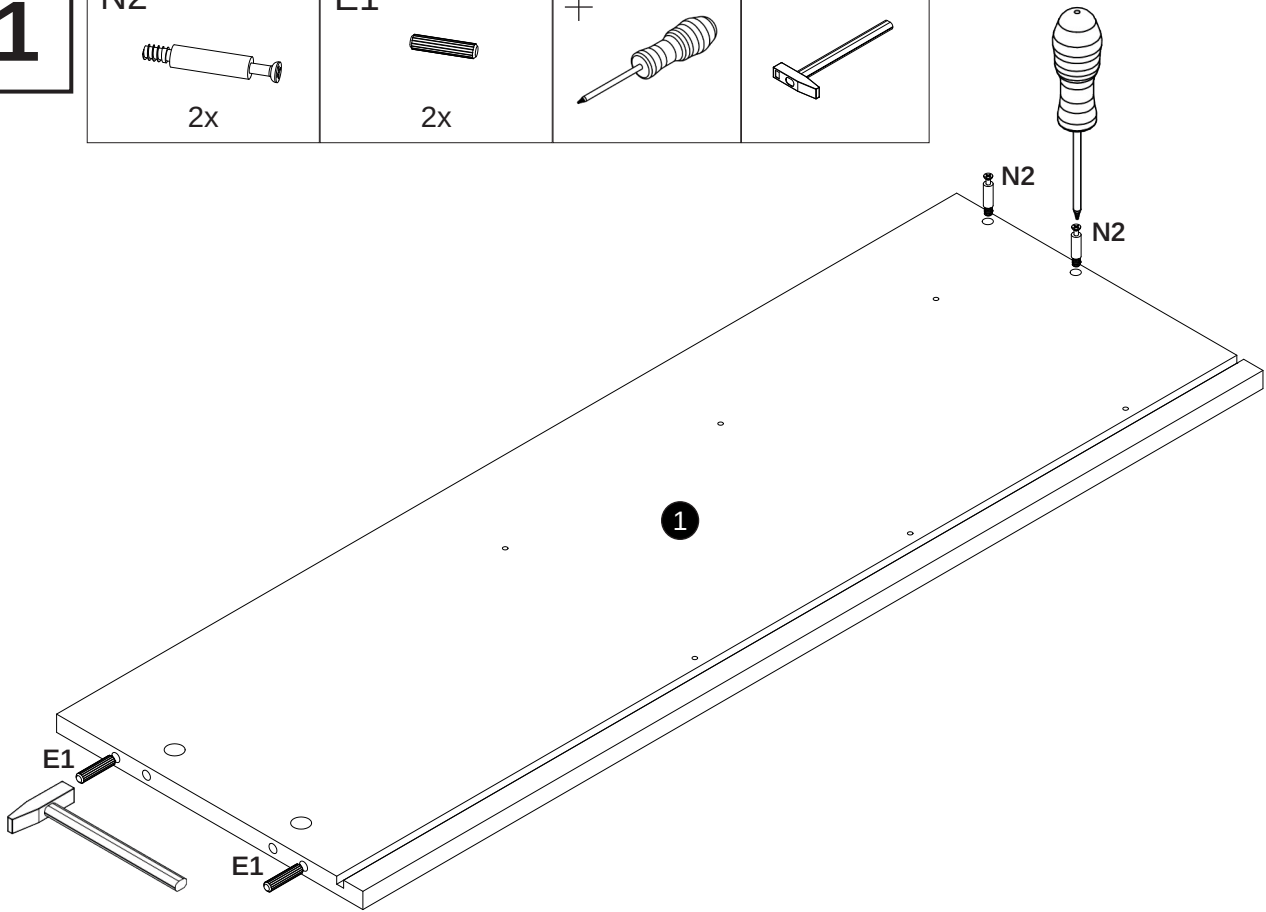
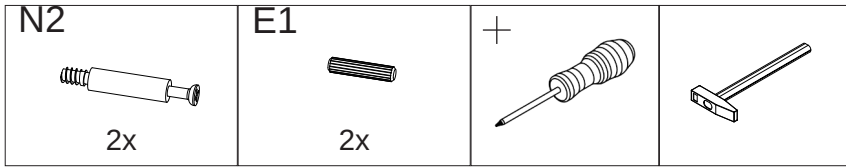

2

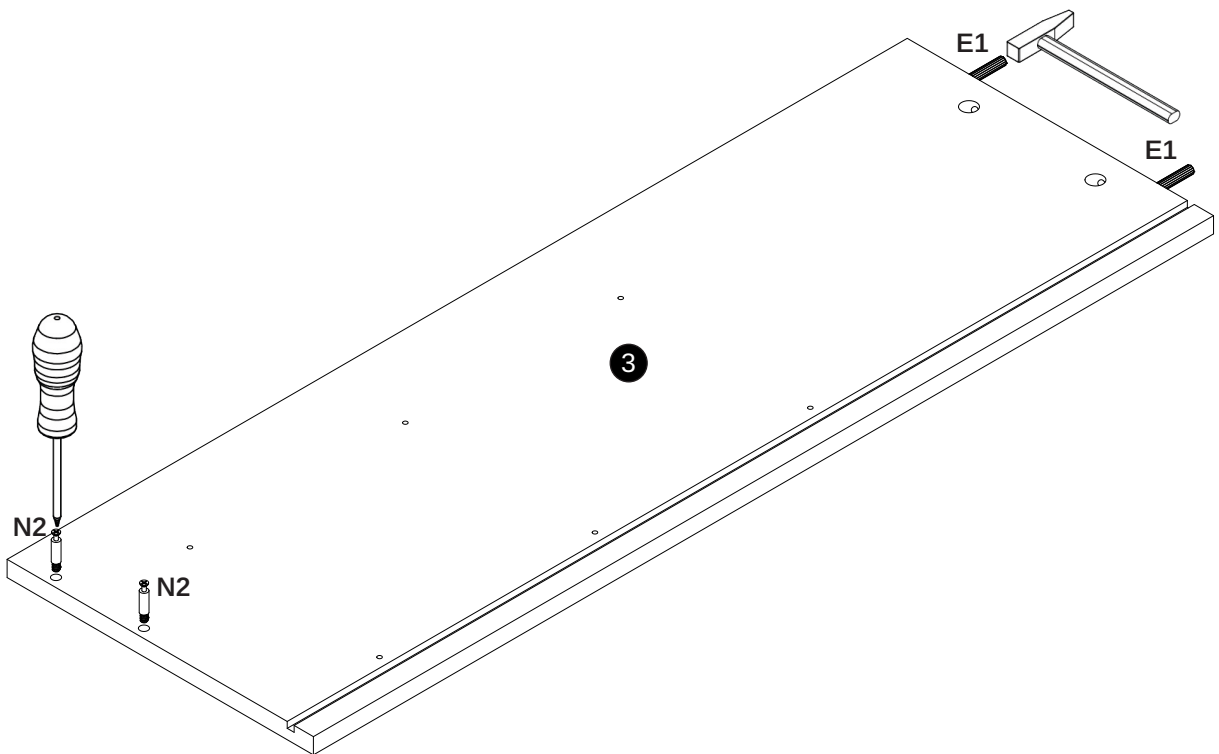
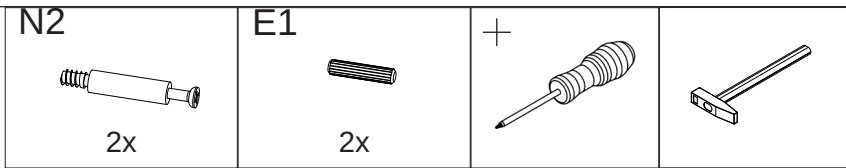

3

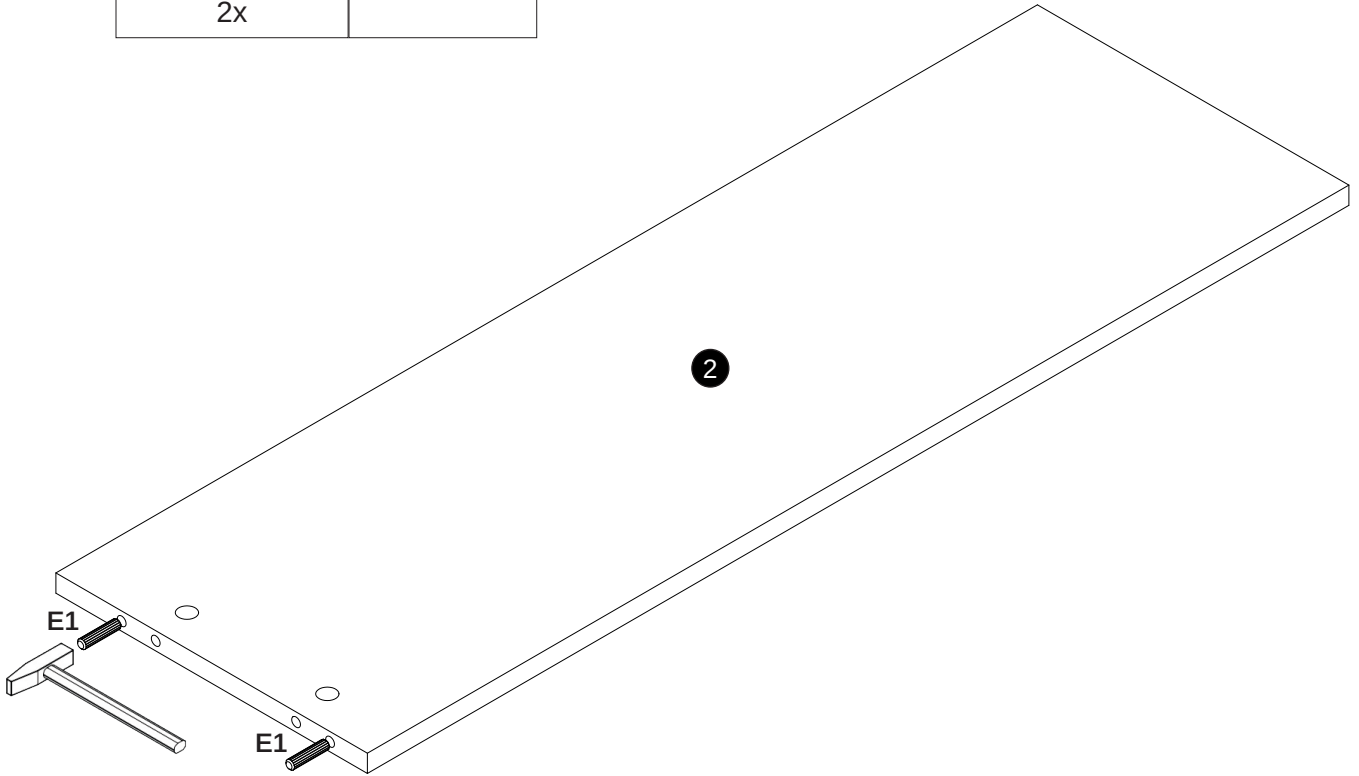
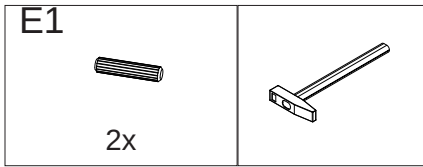

4

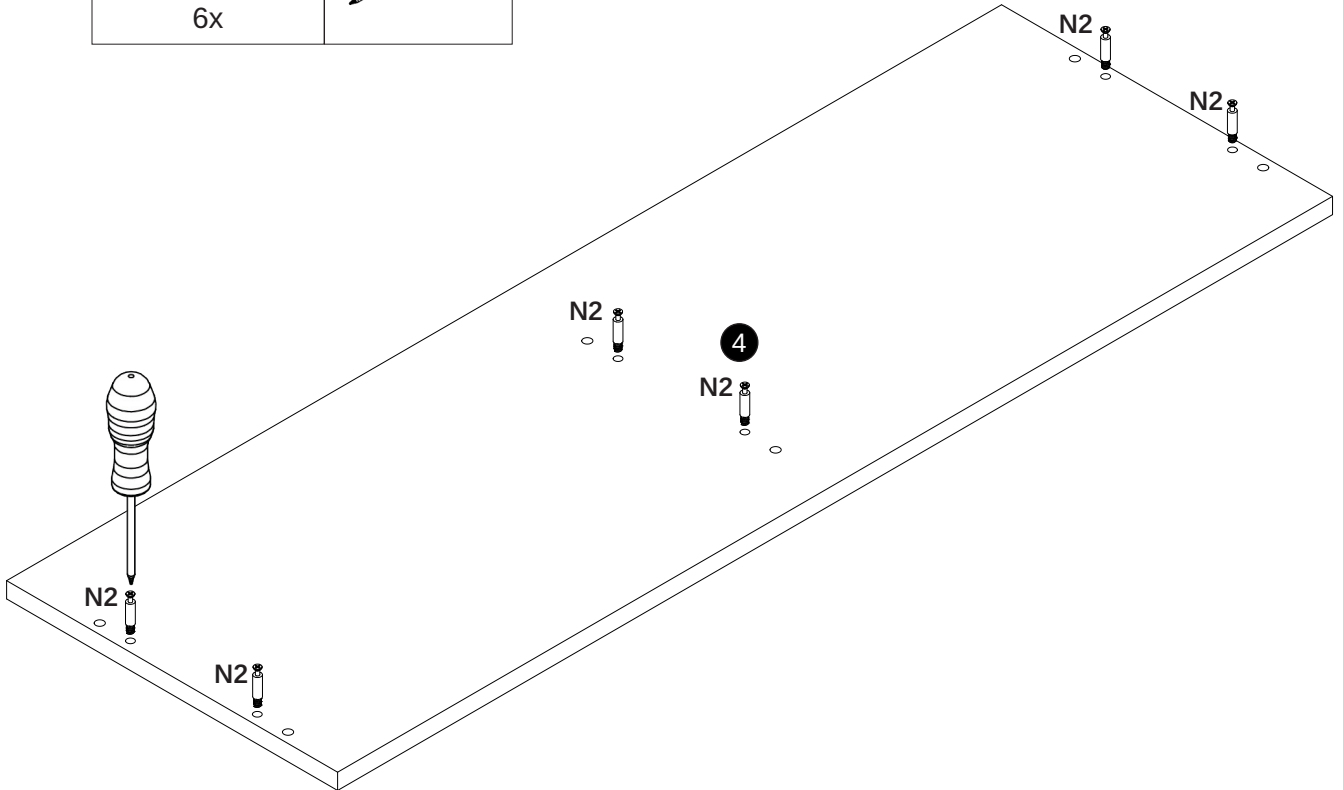
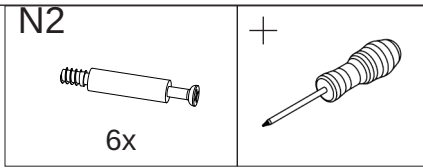

5

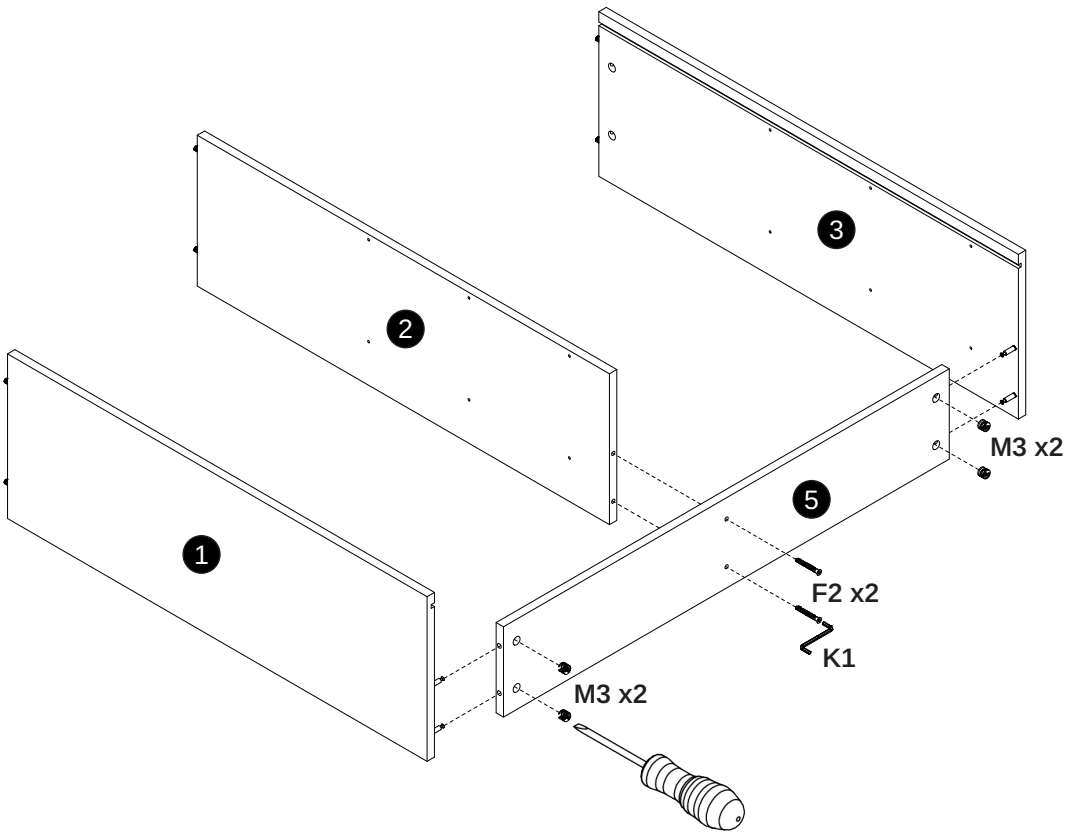
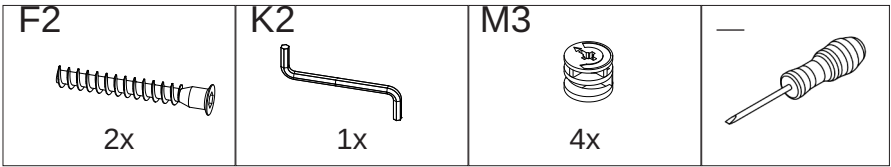

6

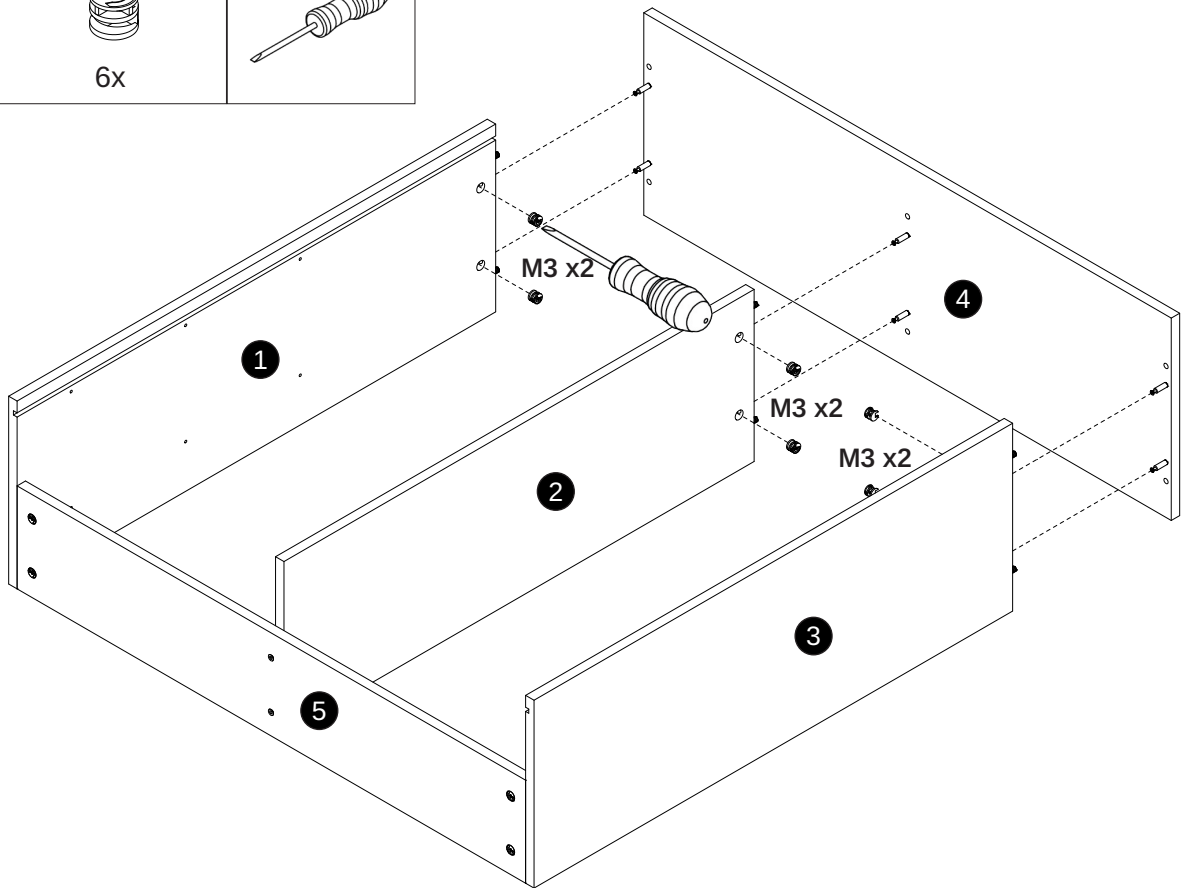
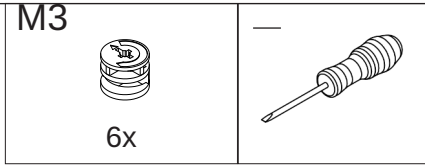

8

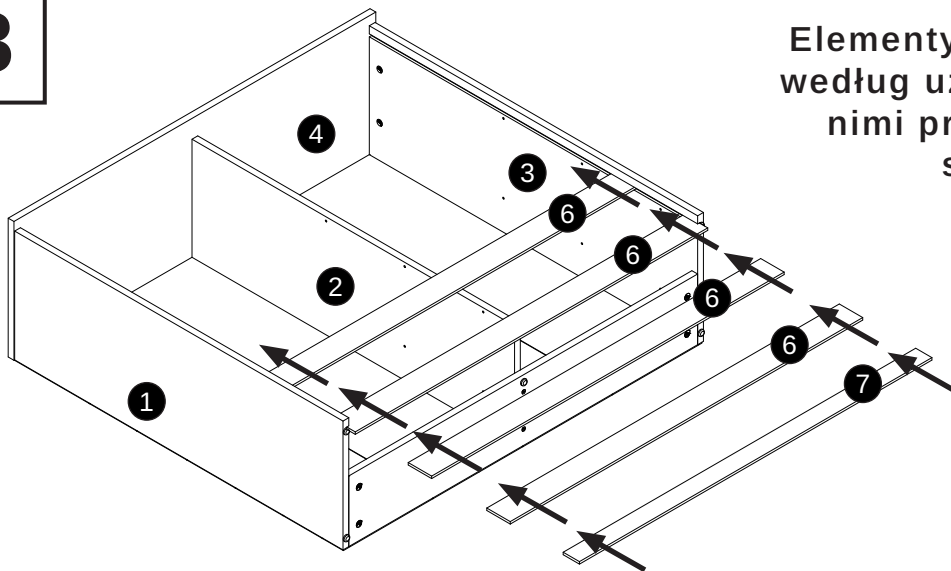

Elementy 6 i 7 zamontować według uznania, wypełniając nimi przestrzeń między szufladami

9

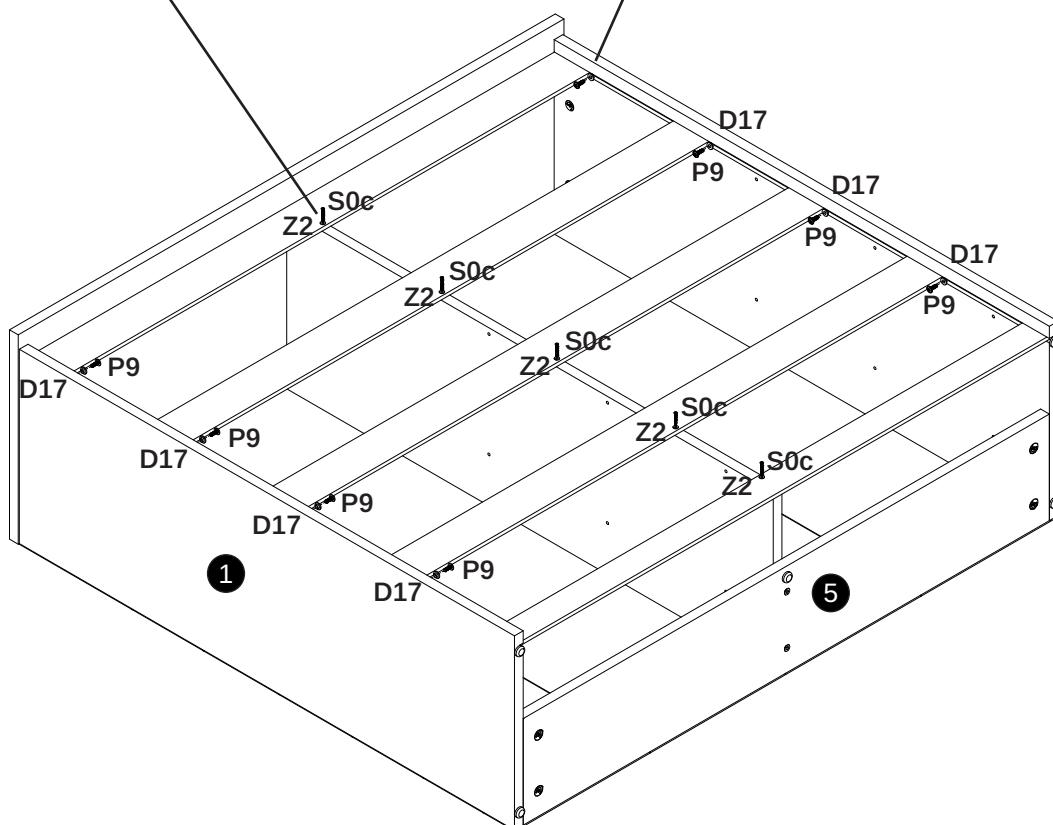
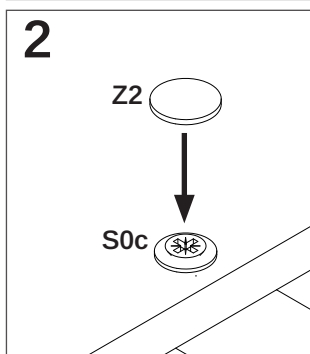
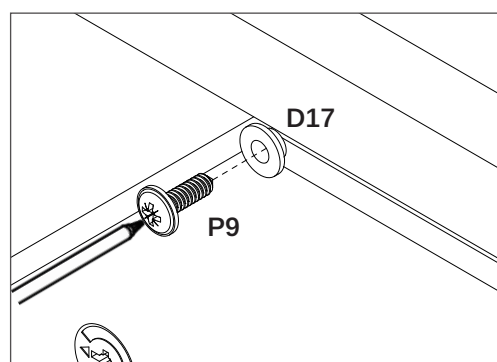
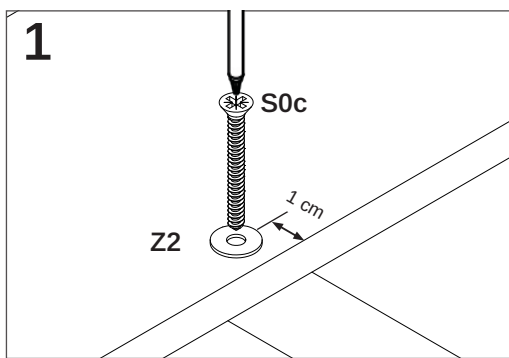
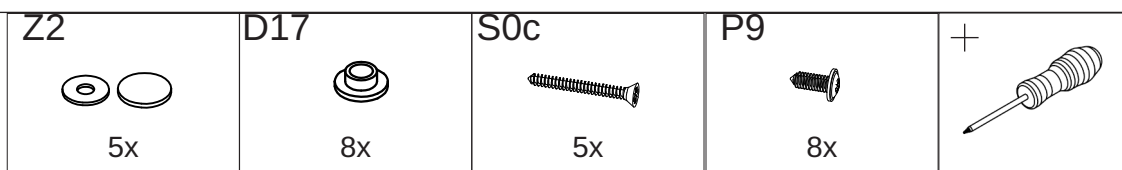

10

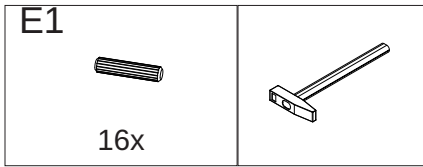

x8

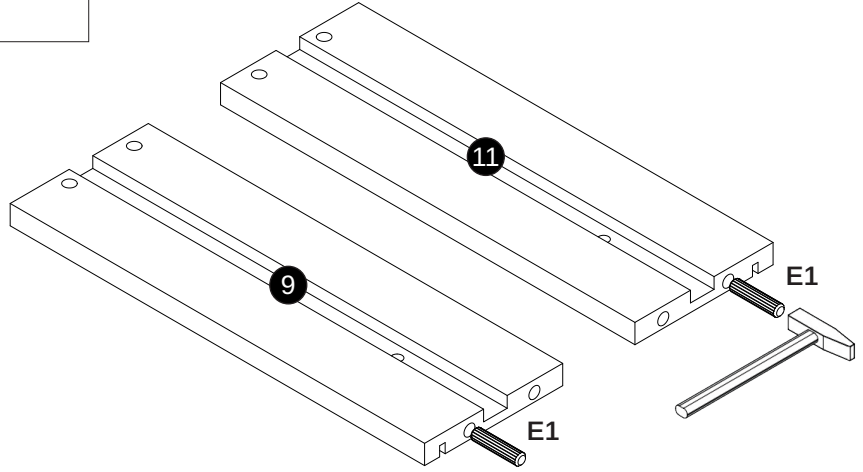

11

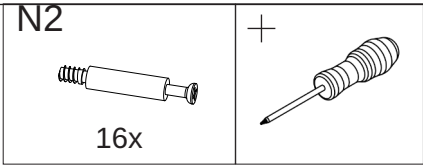

x8

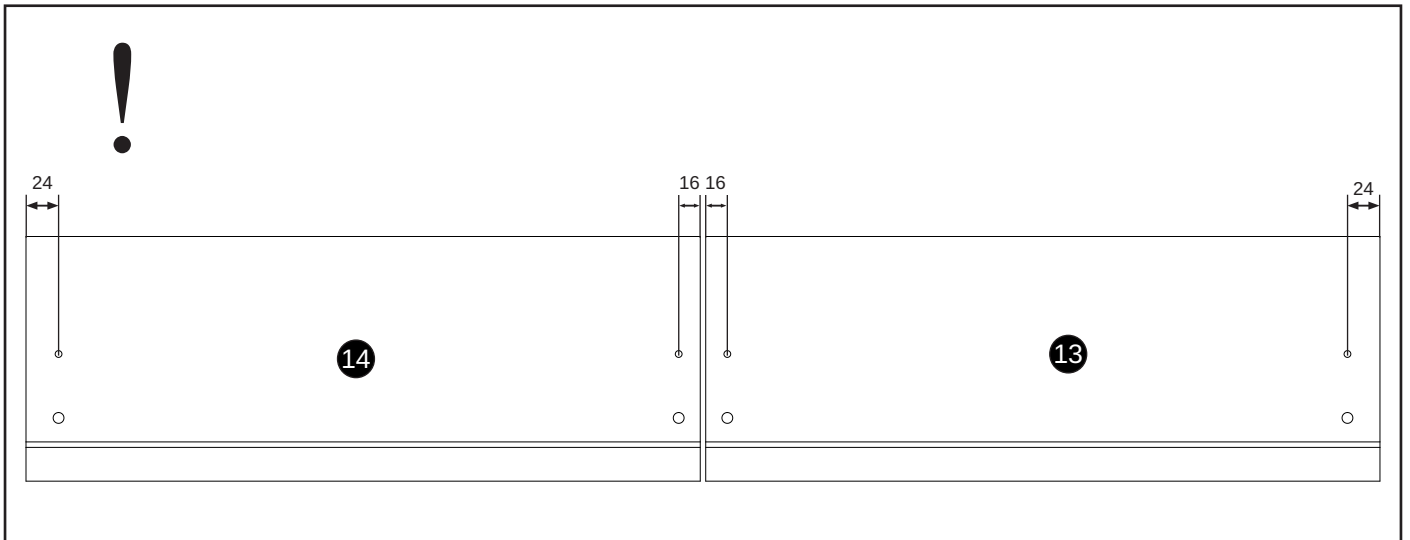
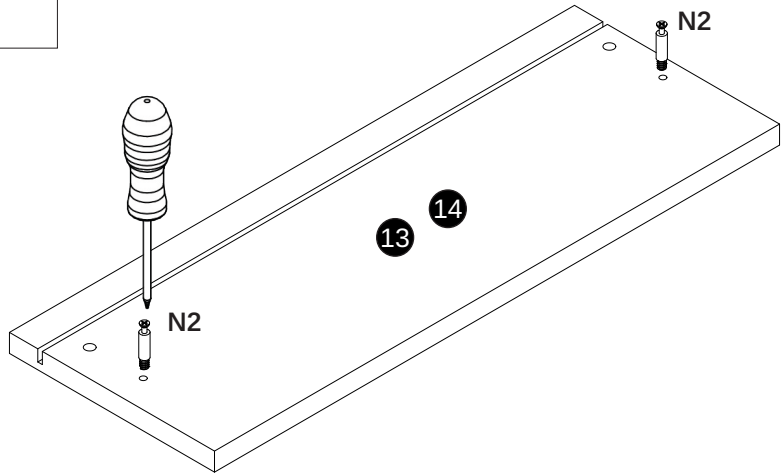

12

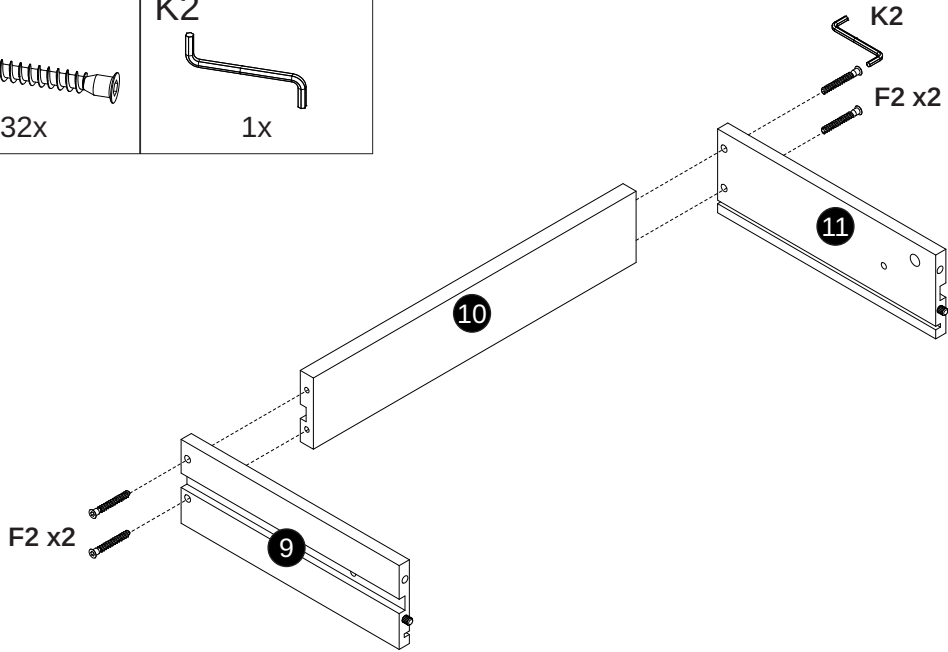
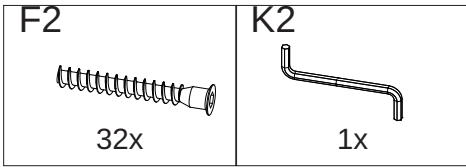

x8

13

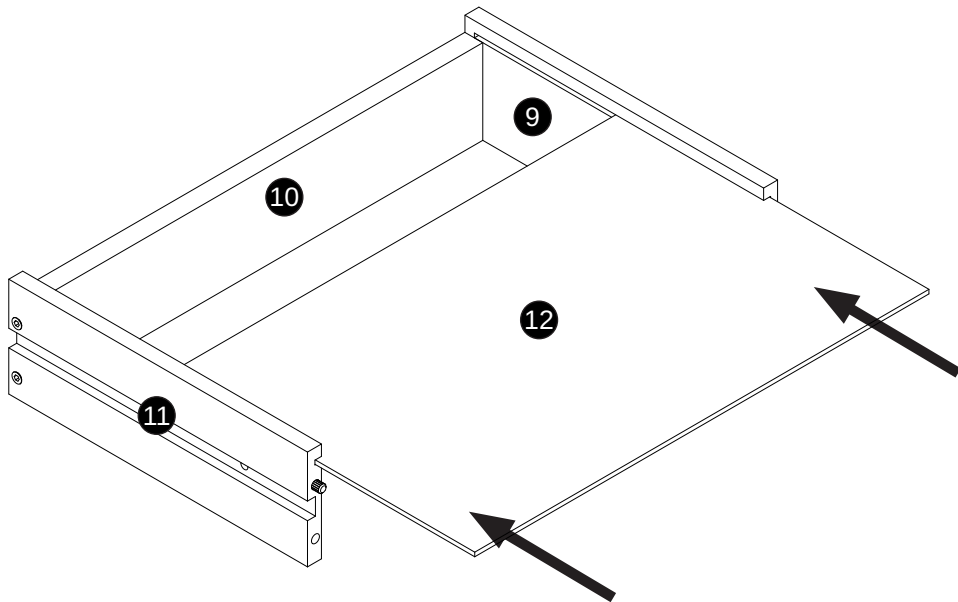

x8

14

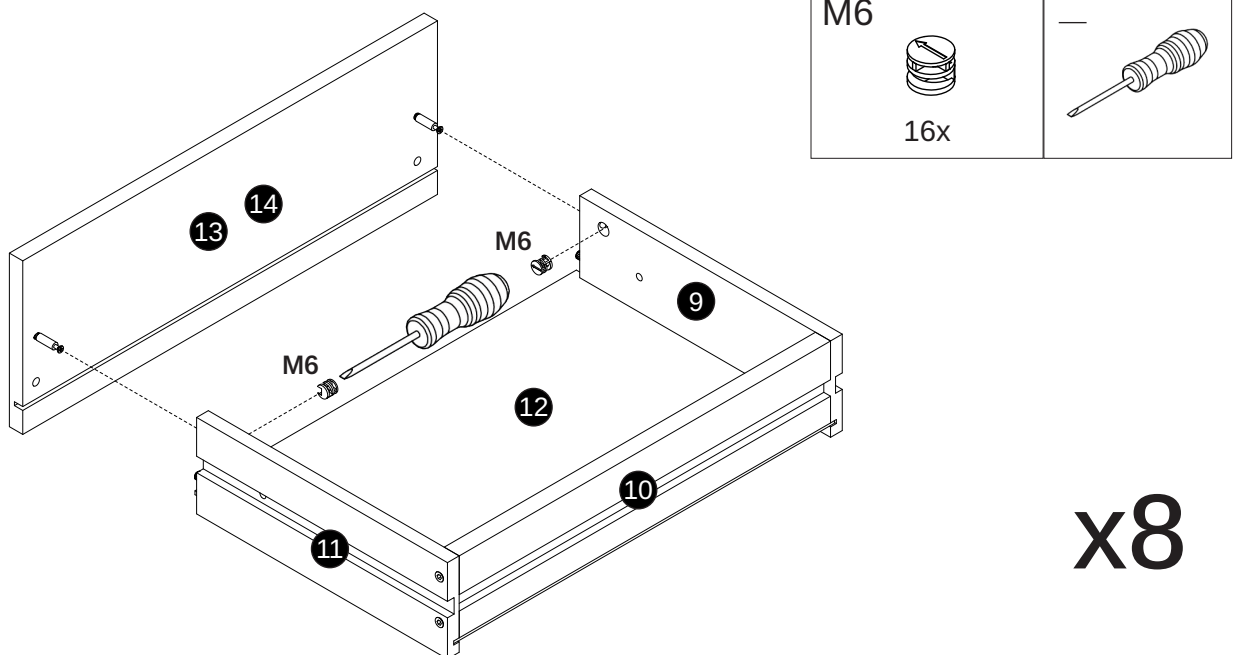

x8

17

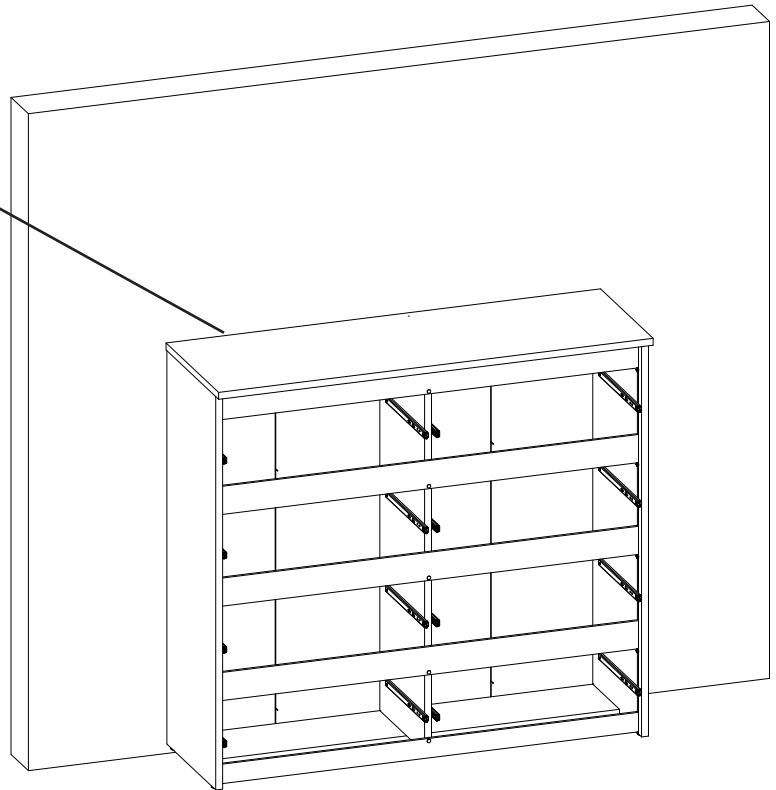
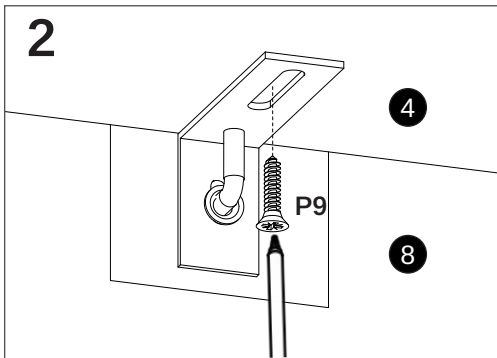
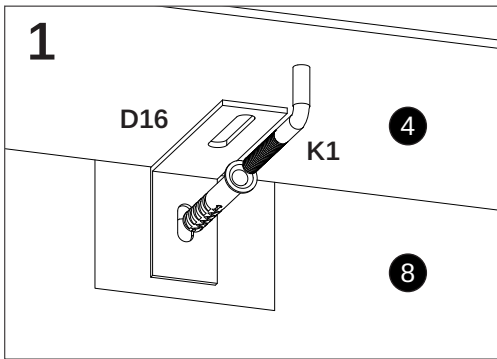
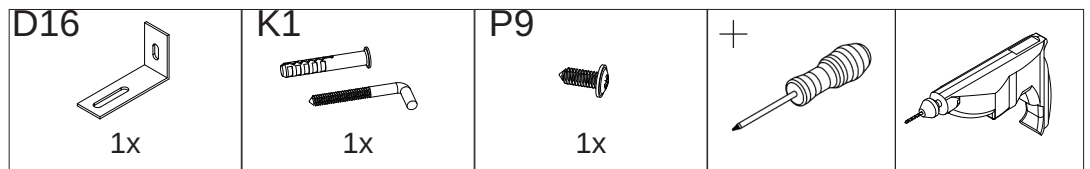

18

