



CERTIFICATE OF CONFORMITY

EU- Electromagnetic Compatibility (EMC) -

No.: CTB210106027EX-ZS

Applicant : Ningbo Shanen Electric Appliance Co., Ltd
Address : No. 3, Tongji Road, Simen Town, Yuyao City, Zhejiang Province
Manufacturer : Ningbo Shanen Electric Appliance Co., Ltd
Address : No. 3, Tongji Road, Simen Town, Yuyao City, Zhejiang Province
Product : Portable car vacuum cleaner
Trade Name : N/A
Model(s) : LT-102C、LT-101C、LT-103C、LT-104C、LT-105C、LT-106C、LT-107C、
 LT-108C、LT-109C、LT-110C、LT-111C、LT-112C、LT-113C、LT-114C、
 LT-115C、LT-116C、LT-117C、LT-118C、LT-119C、LT-120C
Test Report No. : CTB210106027EX
Test Standards : EN 55014-1:2017, EN 55014-2:2015

The tests that base on the above designated product Complies with the essential requirements of Directive 2014/30/EU relating to Electrical Equipment designed for use within Electromagnetic Compatibility.

The test results apply only to the particular sample tested and the applicative tests carried out.

The CE markings as shown below can be affixed on product after manufacturer carry out all stipulation activities integrally of above mentioned Regulation(Directive) and preparation of necessary technical documentation as well as the conformity declaration.

This statement is based on a single evaluation of sample of above mentioned product. It does not imply an assessment of the whole production process.

Other relevant Regulation(Directive) requirement have to be observed.



Paul Pan (Director)

Jan. 06, 2021



Shenzhen CTB Testing Technology Co., Ltd

Add: Floor 1&2, Building A, 26 of Xinhe Road, Xinqiao Community, Xinqiao Street, Baoan District, Shenzhen, Guangdong, China.

Web: www.ctb-lab.net Tel: 4008-707-283 Email: ctb@ctb-lab.net

EMC TEST REPORT

Equipment Portable car vacuum cleaner

Trademark N/A

Model No. LT-102C、LT-101C、LT-103C、LT-104C、LT-105C、LT-106C、LT-107C、LT-108C、LT-109C、LT-110C、LT-111C、LT-112C、LT-113C、LT-114C、LT-115C、LT-116C、LT-117C、LT-118C、LT-119C、LT-120C

Report No. CTB210106027EX

Applicant Ningbo Shanen Electric Appliance Co., Ltd
No. 3, Tongji Road, Simen Town, Yuyao City, Zhejiang Province

Manufacturer Ningbo Shanen Electric Appliance Co., Ltd
No. 3, Tongji Road, Simen Town, Yuyao City, Zhejiang Province

Prepared by Shenzhen CTB Testing Technology Co., Ltd.
Floor 1&2, Building A, No. 26 of Xinhe Road, Xinqiao Street, Baoan District, Shenzhen China
Tel: 4008-707-283
Fax: 086-0755-23208027

Date of Receipt Jan. 04, 2021

Date of Test(s) Jan. 04, 2021~ Jan. 06, 2021

Date of Issue Jan. 06, 2021

Test Standard(s) EN 55014-1:2017, EN 55014-2:2015

In the configuration tested, the EUT complied with the standards specified above.

Producer :  , Date : Jan. 06, 2021
Amy Yang/ Engineer

Signatory :  , Date : Jan. 06, 2021
Paul Pan/ Director



Note: The results shown in this test report refer only to the sample(s) tested unless otherwise stated. This test report shall not be reproduced except in full, without prior written approval of CTB. This document may be altered or revised by CTB, personnel only, and shall be noted in the revision of the document.

Revision History

Edition No.	Date of Revision	Revision Summary	Report Number
0	Jan. 06, 2021	Original Report	CTB210106027EX

Table of Contents

1. TEST SUMMARY	5
2. GENERAL INFORMATION	6
2.1. Description of EUT	6
2.2. Operating condition of EUT	7
2.3. Test conditions	7
2.4. Block diagram of EUT configuration	7
3. FACILITIES	8
3.1. Test Facility	8
3.2. Test Instruments	8
4. Measurement uncertainty	9
5. Emission	10
5.1. Conducted disturbances	10
5.1.1. Continuous conducted disturbance voltage	10
5.1.1.1. Limits	10
5.1.1.2. Test setup	11
5.1.1.3. Test procedure	11
5.1.1.4. Test results	11
5.2. Discontinuous conducted disturbance voltage	12
5.2.1. Limit	12
5.2.2. Block diagram of test setup	12
5.2.3. Test procedure	12
5.2.4. Test results	12
5.3. Radiated disturbances	13
5.3.1. Magnetic field strength – 9 kHz to 30 MHz	13
5.3.1.1. Limits	13
5.3.1.2. Test setup	14
5.3.1.3. Test procedure	14
5.3.1.4. Test results	14
5.3.2. Disturbance power – 30 MHz to 300 MHz	15
5.3.2.1. Limits	15
5.3.2.2. Test setup	15
5.3.2.3. Test procedure	16
5.3.2.4. Test results	16
5.3.3. Radiated emission – 30 MHz to 1 000 MHz	17
5.3.3.1. Limits	17
5.3.3.2. Test setup	17
5.3.3.3. Test procedure	17
5.3.3.4. Test results	17
5.4. Harmonic current emissions	20
5.4.1. Test Setup	20
5.4.2. Test Procedure	20
5.4.3. Test Result	20
5.5. Voltage changes, voltage fluctuations and flicker	21
5.5.1. Test Setup	21
5.5.2. Test Procedure	21
5.5.3. Test Result	21
6. Immunity	22

6.1. Electrostatic discharges	23
6.1.1. Test Levels and Performance Criterion	23
6.1.2. Test setup	23
6.1.3. Test Procedure	23
6.1.4. Test Result	23
6.2. Fast transients	24
6.2.1. Test Levels and Performance Criterion	24
6.2.2. Test setup	24
6.2.3. Test Procedure	25
6.2.4. Test Result	25
6.3. Injected currents	26
6.3.1. Injected currents, 0,15 MHz to 230 MHz	26
6.3.1.1. Test Levels and Performance Criterion	26
6.3.1.2. Test setup	26
6.3.1.3. Test Procedure	27
6.3.1.4. Test Result	27
6.3.2. Injected currents, 0,15 MHz to 80 MHz	28
6.3.2.1. Test Levels and Performance Criterion	28
6.3.2.2. Test setup	28
6.3.2.3. Test Procedure	29
6.3.2.4. Test Result	29
6.4. Radio frequency electromagnetic fields, 80 MHz to 1 000 MHz	30
6.4.1. Test Levels and Performance Criterion	30
6.4.2. Test setup	30
6.4.3. Test Procedure	30
6.4.4. Test Result	30
6.5. Surges	31
6.5.1. Test Levels and Performance Criterion	31
6.5.2. Test setup	31
6.5.3. Test Procedure	31
6.5.4. Test Result	31
6.6. Voltage dips	32
6.6.1. Test Levels and Performance Criterion	32
6.6.2. Test setup	32
6.6.3. Test Procedure	32
6.6.4. Test Result	32
7. Photographs of test setup	33
8. Photographs of EUT	34

1. TEST SUMMARY

Emission		
Requirement - Test	Test Method	Result
Continuous conducted disturbance voltage	EN 55014-1	N/A
Discontinuous conducted disturbance voltage		N/A
Magnetic field strength		N/A
Disturbance power		N/A
Radiated emission		PASS
Harmonic current emissions	EN IEC 61000-3-2	N/A
Voltage changes, voltage fluctuations and flicker	EN 61000-3-3	N/A
Immunity(EN 55014-2:2015)		
Requirement - Test	Test Method	Result
Electrostatic discharges	EN 61000-4-2	PASS
Fast transients	EN 61000-4-4	N/A
Injected currents	EN 61000-4-6	N/A
Radio frequency electromagnetic fields	EN 61000-4-3	PASS
Surges	EN 61000-4-5	N/A
Voltage dips	EN 61000-4-11	N/A

Remark: N/A is abbreviation for Not Applicable.

The test was carried out in all the test modes, only the worst data are list in report.

2. GENERAL INFORMATION

2.1. Description of EUT

Product	Portable car vacuum cleaner
Trade Mark	N/A
Model Name	LT-102C
Serial No.	LT-101C、LT-103C、LT-104C、LT-105C、LT-106C、LT-107C、LT-108C、LT-109C、LT-110C、LT-111C、LT-112C、LT-113C、LT-114C、LT-115C、LT-116C、LT-117C、LT-118C、LT-119C、LT-120C
Model Difference	All model's the function, software and electric circuit are the same, only with a product color and model named different. Test sample model: LT-102C
Rated Power Supply	DC 7.4V, 2600mAh
Rated Power	N/A
Normal Testing Voltage	DC 7.4V, 2600mAh, 19.24Wh
Category	<input type="checkbox"/> I <input type="checkbox"/> II <input checked="" type="checkbox"/> III <input type="checkbox"/> IV
Configuration	<input checked="" type="checkbox"/> Table-top <input type="checkbox"/> Floor-standing
Accessory Device	N/A
Cable Supplied	N/A

Note:

1. The EUT uses following adapter

Adapter	-
Manufacturer	
Model	
AC Input Power	
DC Output Power	
Plug Type	
Power Cord	

2. Other Accessory Device List and Details

Description	Manufacturer	Model	Note
-			

External I/O Cable

Cable Description	Shielded Type	Ferrite Core	Length(m)	Note
-	<input type="checkbox"/> Shielded <input type="checkbox"/> Non-shielded	<input type="checkbox"/> Yes <input type="checkbox"/> No		

3. The above EUT information is declared by manufacturer and for more detailed features description, please refer to the manufacturer's specifications or the User's Manual.

2.2. Operating condition of EUT

To investigate the maximum EMI emission characteristics generates from EUT, the test system was pre-scanning tested base on the consideration of following EUT operation mode or test configuration mode which possible have effect on EMI emission level. Each of these EUT operation mode(s) or test configuration mode(s) mentioned above was evaluated respectively

Pretest Mode	Description
Mode 1	Working

For Radiated Test	
Final Test Mode	Description
Mode 1	Working

2.3. Test conditions

Temperature: 15-35°C

Relative Humidity: 30-60 %

Atmospheric pressure: 800hPa-1060hPa

2.4. Block diagram of EUT configuration

Working

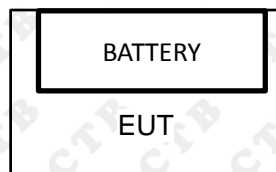

3. FACILITIES

3.1. Test Facility

CTB-LAB

Floor 1&2, Building A, No. 26 of Xinhe Road, Xinqiao Street, Baoan District, Shenzhen China

3.2. Test Instruments

Conducted Emission Measurement (Test software: EZ-EMC Ver. EMC-con3A1.1)

Item	Equipment	Manufacturer	Model No.	Serial No.	Calibrated until
1	AMN	ROHDE&SCHWARZ	ESH3-Z5	831551852	2021.10.30
2	Pulse limiter	ROHDE&SCHWARZ	ESH3Z2	357881052	2021.10.30
3	EMI TEST RECEIVER	ROHDE&SCHWARZ	ESCI	100428/003	2021.11.02
4	Coaxial cable	ZDECL	Z302S	18091904	2021.10.30
5	Clicker Analyzer	DIA1512D	DIA1512D	21555	2021.10.30

Radiated Emission Measurement (Test software: EZ-EMC Ver. FA-03A2 RE)

Item	Equipment	Manufacturer	Model No.	Serial No.	Calibrated until
1	TRILOG Broadband Antenna	Schwarzbeck	VULB 9168	869	2021.11.01
2	Amplifier	HP	8447E	2945A02747	2021.10.30
3	EMI TEST RECEIVER	R&S	ESPI7	100362	2021.10.31
4	Coaxial cable	ETS	RFC-SNS-100-NMS-80 NI	/	2021.10.31
5	Coaxial cable	ETS	RFC-SNS-100-NMS-20 NI	/	2021.10.31
6	Coaxial cable	ETS	RFC-SNS-100-NMS-20 NI	/	2021.10.31
7	Coaxial cable	ETS	RFC-SNS-100-SMS-20 NI	/	2021.10.31

Harmonic Current & Voltage Fluctuation and Flicker (Test software: TTI HA1600 Ver.3.01)

Item	Equipment	Manufacturer	Model No.	Serial No.	Calibrated until
1	Power Analyzer	Laplace Instruments	AC2000A	311363	2021.10.30
2	AC Power source	HTEC Instruments	HPF5010	633088	2021.10.30

Electrostatic Discharge Test

Item	Equipment	Manufacturer	Model No.	Serial No.	Calibrated until
1	ESD Simulator	TESTQ	NSG437	329	2021.11.03

Surge& Electrical Fast Transient/Burst Immunity Test

Item	Equipment	Manufacturer	Model No.	Serial No.	Calibrated until
1	Surge& Burst Generator	Lioncel	LSG-545CB	180602	2021.10.30
2	Capacitive coupling clamp	Lioncel	EFTC	18071801	2021.10.30

Voltage dips and interruptions Test

Item	Equipment	Manufacturer	Model No.	Serial No.	Calibrated until
------	-----------	--------------	-----------	------------	------------------

1	Voltage dip simulator	Lioncel	VDS-1102	180902	2021.10.30
---	-----------------------	---------	----------	--------	------------

4. Measurement uncertainty

The following table is for the measurement uncertainty, which is calculated as per the document CISPR 16-4.

Test	Parameters	Expanded Uncertainty (U_{Lab})	Expanded Uncertainty (U_{Cispr})
Conducted Emission	Level Accuracy: 150kHz to 30MHz	± 1.22 dB	± 3.6 dB
Radiated Emission	Level Accuracy: 30MHz to 1000 MHz	± 3.67 dB	± 5.2 dB
Radiated Emission	Level Accuracy: Above 1000MHz	± 4.79 dB	N/A

This uncertainty represents an expanded uncertainty expressed at approximately the 95% confidence level using a coverage factor of $k=2$.

5. Emission

5.1. Conducted disturbances

5.1.1. Continuous conducted disturbance voltage

5.1.1.1. Limits

Disturbance voltage limits for induction cooking appliances

Frequency range	Appliances which are 1000 V rated and without an earth connection		All other appliances	
	dB μ V Quasi-peak	dB μ V Average	dB μ V Quasi-peak	dB μ V Average
0,009 to 0,050	122	-	110	-
0,050 to 0,150	Decreasing linearly with logarithm of frequency from 102 to 92		Decreasing linearly with logarithm of frequency from 90 to 80	
0,150 to 0,5	Decreasing linearly with logarithm of frequency from			
	72 to 62	60 to 52	66 to 56	56 to 46
0,5 to 5	56	46	56	46
5 to 30	60	50	60	50

The lower limit applies at the transition frequencies.

General limits

Frequency range	Mains ports		Associated ports			
	Disturbance voltage		Disturbance voltage		Disturbance current	
MHz	Quasi-peak dB μ V	Average dB μ V	Quasi-peak dB μ V	Average dB μ V	Quasi-peak dB μ A	Average dB μ A
0,15 to 0,50	Decreasing linearly with the logarithm of the frequency from: 66 to 56 59 to 46		80	70	Decreasing linearly with the logarithm of the frequency from: 40 to 30 30 to 20	
0,50 to 5	56	46	74	64	30	20
5 to 30	60	50	74	64		

The lower limit applies at the transition frequencies.
The test report shall state which test method was used and which limits were applied.

Limits for mains port of tools

Frequency range	$P \leq 700$ W		700 W < $P \leq 1\ 000$ W		$P > 1\ 000$ W	
	Quasi-peak dB μ V	Average dB μ V	Quasi-peak dB μ V	Average dB μ V	Quasi-peak dB μ V	Average dB μ V
0,15 to 0,35	Decreasing linearly with the logarithm of the frequency from:					
	66 to 59	59 to 49	70 to 63	63 to 53	76 to 69	69 to 59
0,35 to 5	59	49	63	53	69	59
5 to 30	64	54	68	58	74	64

The lower limit applies at the transition frequencies.
Key
P = rated power of the motor only.

5.1.1.2. Test setup

For table-top equipment

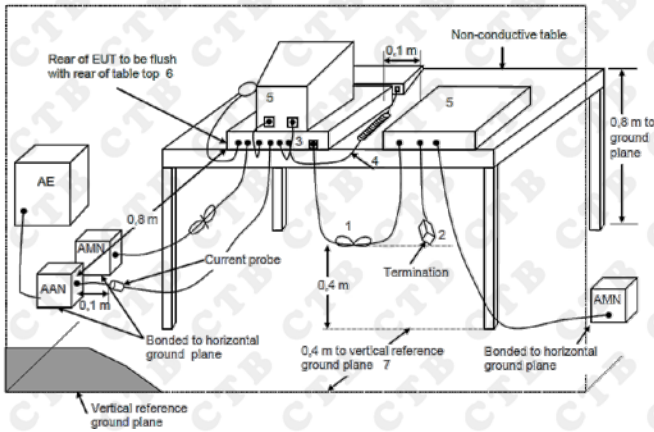

For floor standing equipment

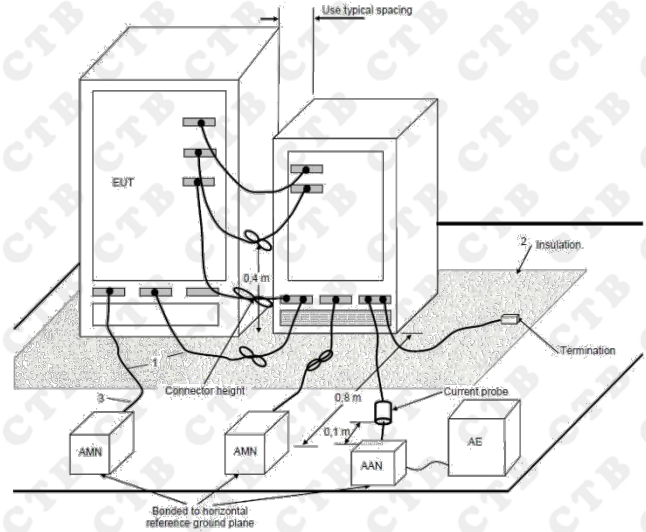

5.1.1.3. Test procedure

Measurement was performed in shielded room, and instruments used were followed CISPR 16-2-1 clause 7.

Detailed test procedure was following clause 7 of CISPR 16-2-1.

Frequency range 9kHz – 150kHz was checked and EMI receiver measurement bandwidth was set to 200Hz.

Frequency range 150kHz – 30MHz was checked and EMI receiver measurement bandwidth was set to 9 kHz.

5.1.1.4. Test results

N/A

EUT not applicable to this test.

5.2. Discontinuous conducted disturbance voltage

5.2.1. Limit

The click limit L_q is calculated by increasing the relevant quasi-peak limit L for continuous disturbances by:

44 dB for $N < 0,2$, or

20 lg (30/N) dB for $0,2 \leq N < 30$

The click rate N is in general the number of clicks per minute determined from the formula $N = n_1/T$, where n_1 is the number of clicks during the observation time T minutes.

In alternative, for certain equipment the click rate N may be determined from the formula $N = n_2 \times f/T$, where n_2 is the number of switching operations during the observation time T and f is a factor depending on the particular equipment, as given in standard EN 55014-1:2017 Annex B Table B.1.

5.2.2. Block diagram of test setup

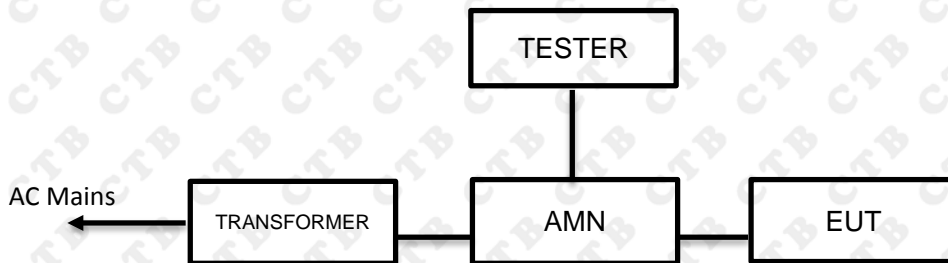

5.2.3. Test procedure

1. The measurements of the number of clicks for determining the click rate shall be carried out only on two frequencies: 150 kHz and 500 kHz.

The click rate is determined from the formula: $N = n_1/T$.

2. After determining the click rate it is recommended to prove the applicability of the exception instantaneous switching. If the therein given conditions apply (duration of all clicks < 20 ms, 90 % of them with a duration < 10 ms, click rate $N < 5$), the procedure can be stopped. A measurement of the amplitudes of the clicks in this case is not necessary, the EUT passed the test.

3. If the measurements of the click rate, duration and spacing of the clicks established that the relaxed limits for discontinuous disturbance can be applied, the amplitude of the clicks shall be evaluated by using the upper quartile method.

The frequency 150kHz, 500kHz, 1.4MHz, 30MHz was checked.

5.2.4. Test results

N/A

Not applicable.

5.3. Radiated disturbances

5.3.1. Magnetic field strength – 9 kHz to 30 MHz

5.3.1.1. Limits

Magnetic field strength limits

Frequency range MHz	Limits at 3 m distance ^{a, b} Quasi-peak dB μ A/m
0,009 to 0,070	69
0,070 to 0,150	Decreasing linearly with logarithm of frequency from 69 to 39
0,150 to 4,0	Decreasing linearly with logarithm of frequency from 39 to 3
4,0 to 30	3

^a The measurements are performed at 3 m distance with a 0,6 m loop antenna as described in 4.3.2 of CISPR 16-1-4:2010.

^b The antenna shall be installed vertically, with the lower edge of the loop at 1 m height above the floor.

Limits of the magnetic field induced current

Frequency range MHz	Limits at 3 m distance ^{a, b} Quasi-peak dB μ A/m
0,009 to 0,070	69
0,070 to 0,150	Decreasing linearly with logarithm of frequency from 69 to 39
0,150 to 4,0	Decreasing linearly with logarithm of frequency from 39 to 3
4,0 to 30	3

^a The measurement is performed using the 2 m loop antenna system (LAS) as described in 7.2 of CISPR 16-2-3:2010.

^b Current induced by the horizontal component of the magnetic field.

^c Current induced by the vertical component of the magnetic field.

5.3.1.2. Test setup

Use loop antenna

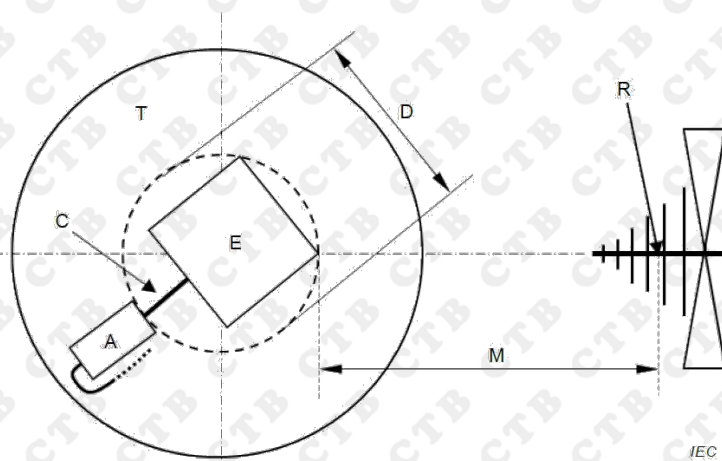

- A Common Mode Absorption Device
- C Cable(s) leaving the EUT and within the test volume of diameter D
- D Diameter of the circle enclosing the EUT including the cables
- E EUT
- M Measuring Distance 3m
- R Antenna Reference Point
- T Turntable

Use LAS

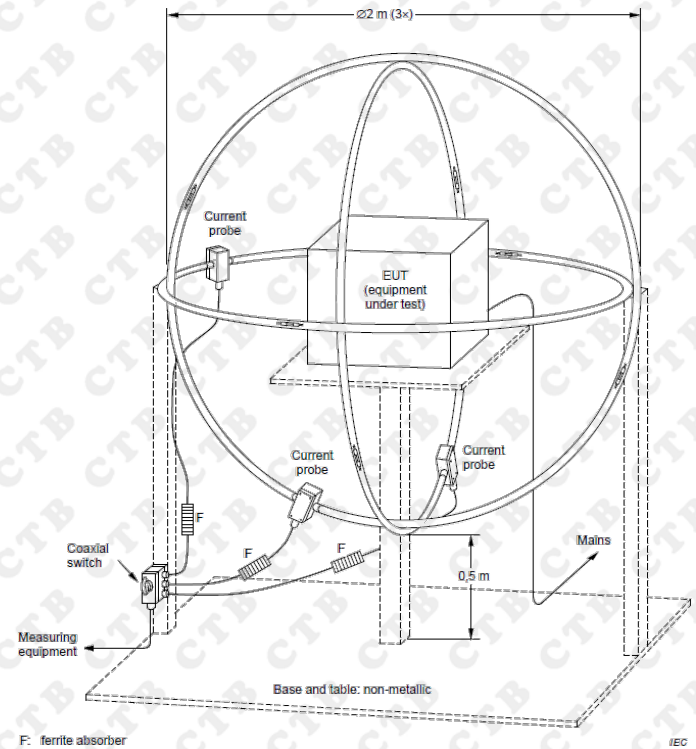

5.3.1.3. Test procedure

The measurement of radiated disturbances in the frequency range 9 kHz to 30 MHz shall be made in accordance with CISPR 16-2-3.

The measurement (Use loop antenna) was performed in a semi-anechoic chamber.

The measurement (Use LAS) was performed in a semi-anechoic chamber or shielded room. Frequency range 9kHz – 150kHz was checked and EMI receiver measurement bandwidth was set to 200Hz.

Frequency range 150kHz – 30MHz was checked and EMI receiver measurement bandwidth was set to 9 kHz.

5.3.1.4. Test results

N/A.

5.3.2. Disturbance power – 30 MHz to 300 MHz

5.3.2.1. Limits

Table 1 - Disturbance power limits – 30 MHz to 300 MHz

Frequency range	General		Tools					
			$P \leq 700 \text{ W}$		$700 \text{ W} < P \leq 1\,000 \text{ W}$		$P > 1\,000 \text{ W}$	
1	2	3	4	5	6	7	8	9
MHz	Quasi-peak dBpW	Average dBpW	Quasi-peak dBpW	Average dBpW	Quasi-peak dBpW	Average dBpW	Quasi-peak dBpW	Average dBpW
30 to 300	45 to 55	35 to 45	45 to 55	35 to 45	49 to 59	39 to 49	55 to 65	45 to 55
Increasing linearly with the frequency from:								
Key								
P = rated power of the motor only.								

Note:

If the quasi-peak measurements meet the average limit, the EUT shall be deemed to meet both limits and the measurements using the average detector need not be carried out.

Table 2 - Reduction applicable to Table 1 limit

Frequency range	General		Tools					
			$P \leq 700 \text{ W}$		$700 \text{ W} < P \leq 1\,000 \text{ W}$		$P > 1\,000 \text{ W}$	
1	2	3	4	5	6	7	8	9
MHz	Quasi-peak dBpW	Average dBpW	Quasi-peak dBpW	Average dBpW	Quasi-peak dBpW	Average dBpW	Quasi-peak dBpW	Average dBpW
200 to 300	0 to 10	0	0 to 10	0	0	0 to 10	0 to 10	0
Increasing linearly with the frequency from:								
Key								
P = rated power of the motor only.								

5.3.2.2. Test setup

For table-top equipment

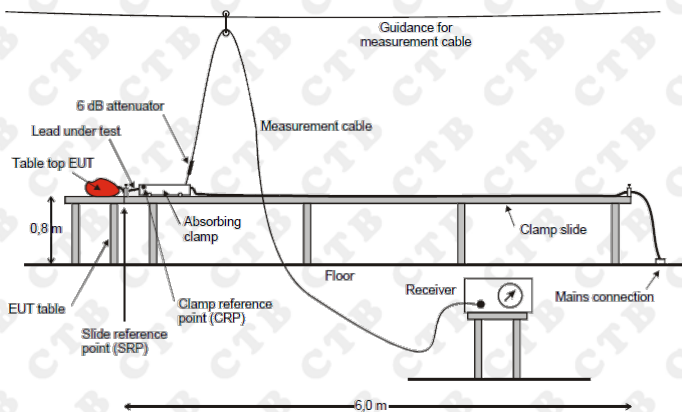

For floor standing equipment

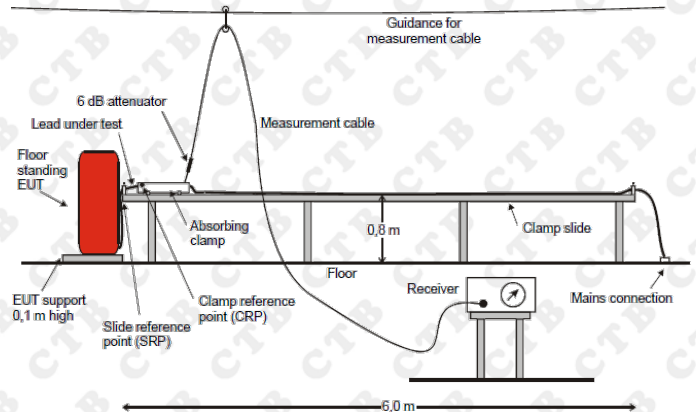

5.3.2.3. Test procedure

The disturbance power is measured on the cables attached to the ports of the EUT according to Clause 7 of CISPR 16-2-2 and the methods described in this standard.

The measurement was performed in a shielded room.

Frequency range 30MHz – 300MHz was checked and EMI receiver measurement bandwidth was set to 120 kHz.

Note:

The EUT shall be also deemed to comply with the requirement of this standard in the frequency range from 300 MHz to 1 000 MHz without further testing if both conditions 1) and 2) below are fulfilled:

1) the disturbance power emission from the EUT is lower than the limits of Table 1 reduced by the values of Table 2;

2) the maximum clock frequency is less than 30 MHz

If either of the conditions 1) or 2) is not fulfilled, radiated measurements in the frequency range from 300 MHz to 1 000 MHz shall be performed and the limits of Table 3 for that range applied.

In any case, the limits of Table 1 in the frequency range 30 MHz to 300 MHz shall be met.

5.3.2.4. Test results

N/A

5.3.3. Radiated emission – 30 MHz to 1 000 MHz

5.3.3.1. Limits

Table 2 - Radiated disturbance limits and testing methods – 30 MHz to 1 000 MHz

Testing method	Basic standard	Frequency range MHz	Limit ^a Quasi-peak dB μ V/m	Remarks
SAC	CISPR 16-2-3	30 to 230	40	Measurement distance 3 m
		230 to 1000	47	

^a The lower limit is applies at the transition frequency.

5.3.3.2. Test setup

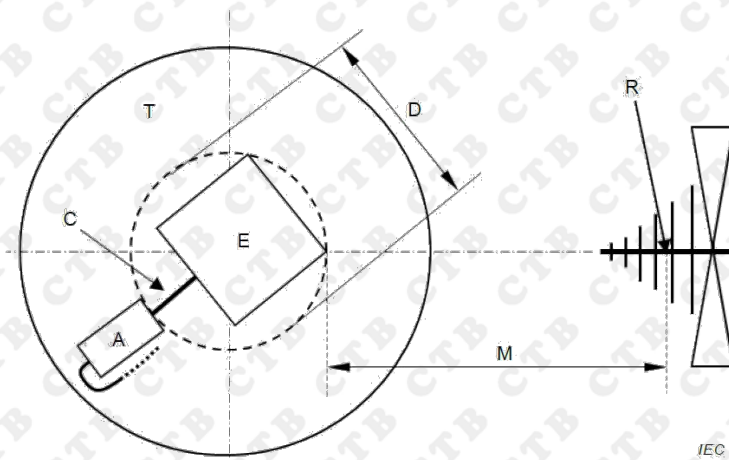

A Common Mode Absorption Device

D Diameter of the circle enclosing the EUT including the cables

M Measuring Distance 3m

T Turntable

C Cable(s) leaving the EUT and within the test volume of diameter D

E EUT

R Antenna Reference Point

5.3.3.3. Test procedure

The measurement was performed in a semi-anechoic chamber.

The distance from EUT to receiving antenna is 3 meters.

Measurement was performed according to clause 7.3 of CISPR 16-2-3.

5.3.3.4. Test results

PASS.

Please refer to the following page.

Polarization: H

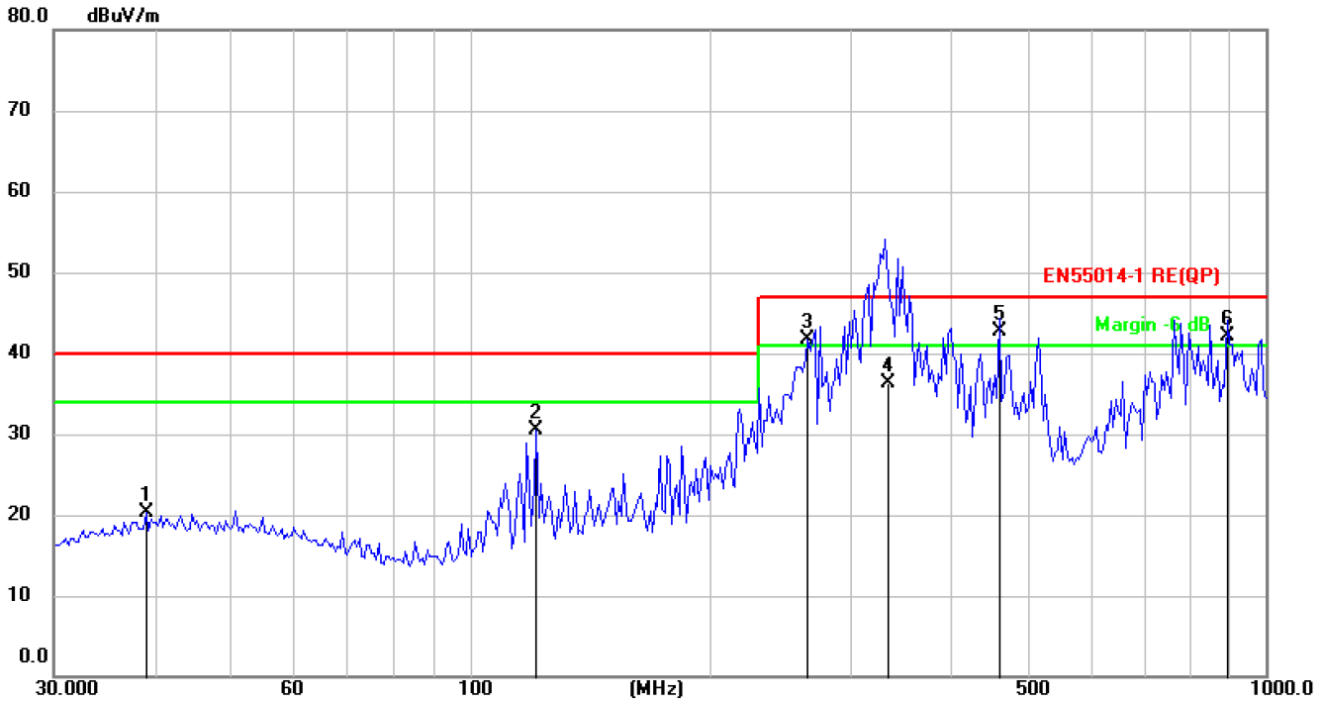

No.	Mk.	Freq. MHz	Reading Level dBuV	Correct Factor dB	Measure- ment dBuV/m	Limit dB/m	Margin dB	Antenna Height cm	Table Degree degree	Comment
1		39.1615	26.68	-6.45	20.23	40.00	-19.77			QP
2		121.1231	38.41	-7.97	30.44	40.00	-9.56			QP
3	!	265.6757	48.93	-7.23	41.70	47.00	-5.30			QP
4		334.7590	41.42	-5.08	36.34	47.00	-10.66	100	168	
5	*	462.3455	44.70	-2.08	42.62	47.00	-4.38			QP
6	!	893.8566	35.80	6.35	42.15	47.00	-4.85			QP

Note: Result=Reading+Factor
Over Limit=Result-Limit

Polarization: V

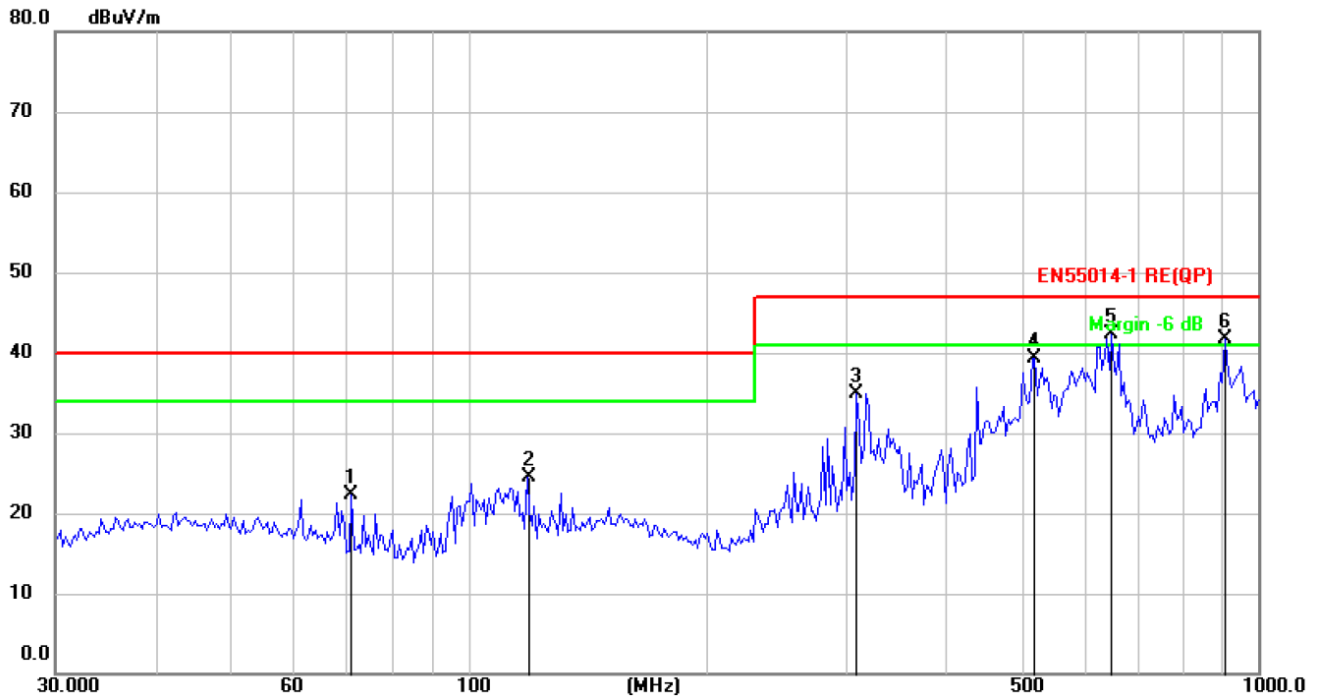

No.	Mk.	Freq.	Reading Level	Correct Factor	Measurement	Limit	Margin	Antenna Height	Table Degree	
		MHz	dBuV	dB	dBuV/m	dB/m	dB	cm	degree	Comment
1		71.0803	31.82	-9.51	22.31	40.00	-17.69			QP
2		118.6014	32.63	-8.13	24.50	40.00	-15.50			QP
3		309.9977	40.47	-5.65	34.82	47.00	-12.18			QP
4		520.8882	39.83	-0.53	39.30	47.00	-7.70			QP
5	*	651.9417	39.53	2.82	42.35	47.00	-4.65			QP
6	!	906.4824	35.22	6.53	41.75	47.00	-5.25			QP

Note: Result=Reading+Factor
Over Limit=Result-Limit

5.4. Harmonic current emissions

5.4.1. Test Setup

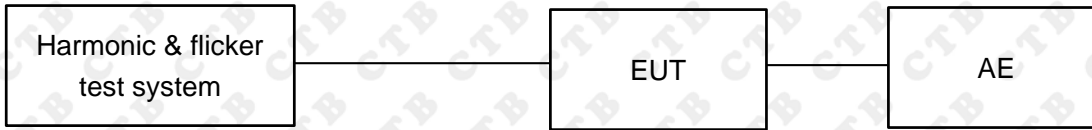

5.4.2. Test Procedure

Basic Standard(s)	: EN IEC 61000-3-2:2019
Measurement Equipment requirement	: IEC 61000-4-7
Measured Harmonics	: 1 - 40
Equipment Class	: <input checked="" type="checkbox"/> A <input type="checkbox"/> B <input type="checkbox"/> C <input type="checkbox"/> D
Limits	: <input checked="" type="checkbox"/> Clause 7.1 Table 1 <input type="checkbox"/> Clause 7.2 <input type="checkbox"/> Clause 7.3 Table 2 <input type="checkbox"/> Clause 7.4 Table 3

- This product is not defined as lighting equipment, and has rated power less than 75W, therefore, no limit applies according to EN 61000-3-2
- The EUT is kitchen machines as listed in the scope of IEC 60335-2-14, therefore, is deemed to conform to the harmonic current limits of this standard without further testing.

5.4.3. Test Result

N/a

No adapters ,EUT not applicable to this test.

5.5. Voltage changes, voltage fluctuations and flicker

5.5.1. Test Setup

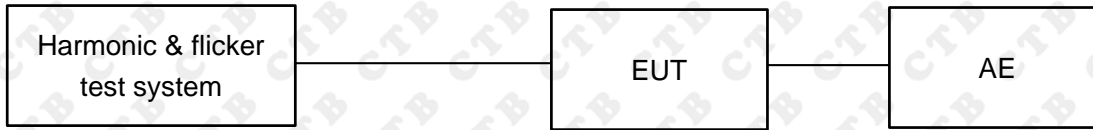

5.5.2. Test Procedure

Basic Standard(s)	: EN 61000-3-3:2013/A1:2019
Measurement Equipment requirement	: IEC 61000-4-15
Limits	: Clause 5

5.4.2.1 Definition

Flicker: impression of unsteadiness of visual sensation induced by a lighting stimulus whose luminance or spectral distribution fluctuates with time.

P_{st} : Short-term flicker indicator the flicker severity evaluated over a short period (in minutes);

$P_{st}=1$ is the conventional threshold of irritability

P_{lt} : long-term flicker indicator; the flicker severity evaluated over a long period (a few hours) using successive P_{st} values.

dc: the relative steady-state voltage change

d_{max} : the maximum relative voltage change

$d(t)$: the value during a voltage change

5.4.2.2 Test Procedure

The following limits apply

- " P_{lt} " shall not exceed 0.65.
- " P_{st} " shall not exceed 1.0.
- "dc" shall not exceed 3.3%.
- " $d(t)$ " shall not exceed 3.3% for more than 500ms.
- " d_{max} " shall not exceed:
 - 4% without additional conditions,
 - 6% switched manually or automatically more than twice per day,
 - 7% attended whilst in use or switched automatically for no more than twice per day or attended while in use.
 - For manual switch, d_{max} is measured in accordance with Annex B of standard, average d_{max} is calculated from 24 times measurement.
 - The EUT is unlikely to produce significant voltage fluctuations or flicker by technical analysis and evaluation. So it is deemed to fulfil the requirements without testing.

5.5.3. Test Result

N/a

No adapters ,EUT not applicable to this test.

6. Immunity

Performance criteria

Performance criterion **A**: The apparatus shall continue to operate as intended during the test. No degradation of performance or loss of function is allowed below a performance level (or permissible loss of performance) specified by the manufacturer, when the apparatus is used as intended. If the minimum performance level or the permissible performance loss is not specified by the manufacturer, then either of these may be derived from the product description and documentation, and from what the user may reasonably expect from the apparatus if used as intended.

Performance criterion **B**: The apparatus shall continue to operate as intended after the test. No degradation of performance or loss of function is allowed below a performance level (or permissible loss of performance) specified by the manufacturer, when the apparatus is used as intended. During the test, degradation of performance is allowed, however no change of actual operating state or stored data is allowed to persist after the test. If the minimum performance level or the permissible performance loss is not specified by the manufacturer, then either of these may be derived from the product description and documentation, and from what the user may reasonably expect from the apparatus if used as intended.

Performance criterion **C**: Temporary loss of function is allowed, provided the function is self-recoverable or can be restored by the operation of the controls, or by any operation specified in the instructions for use.

6.1. Electrostatic discharges

6.1.1. Test Levels and Performance Criterion

Environmental phenomenon	Test specifications	Test set-up
Electrostatic discharge	8 kV air discharge 4 kV contact discharge	IEC 61000-4-2

Performance criterion: **B**

6.1.2. Test setup

For table-top equipment

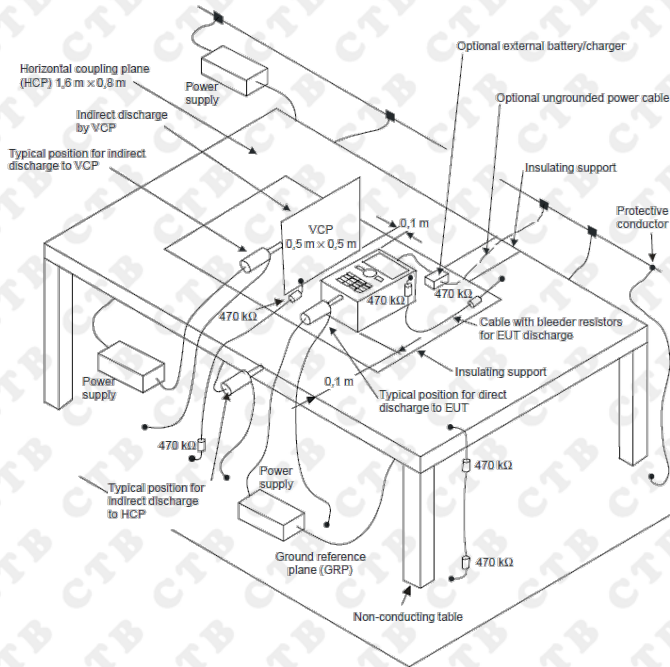

For floor standing equipment

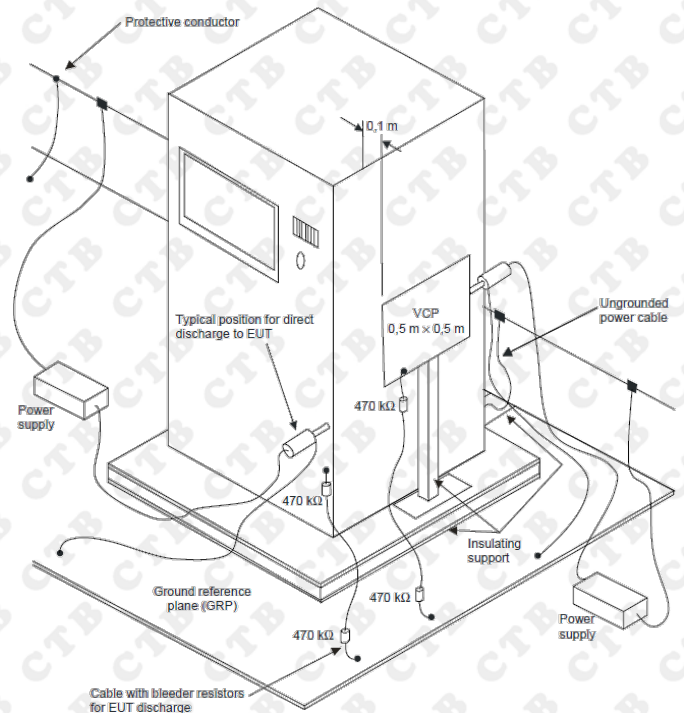

6.1.3. Test Procedure

Measurement was performed in shielded room.

Measurement procedure was applied according to EN 61000-4-2 clause 8.

The test methods and equipment were specified by EN 61000-4-2.

6.1.4. Test Result

PASS

No.	Location of discharge	Polarity	Discharge	Number of discharges	Test level kV	Result
1	HCP	P&N	C	25	4	PASS
2	VCP	P&N	C	25	4	PASS
3	Points on conductive surface	P&N	C	25	4	PASS
4	Points on non-conductive surface	P&N	A	10	8	PASS

HCP =Horizontal coupling plate VCP =Vertical coupling plate N Negative P Positive A =Air discharge C =Contact discharge

6.2. Fast transients

6.2.1. Test Levels and Performance Criterion

Ports for signal lines and control lines

Environmental phenomenon	Test specifications	Test set-up
Fast transients common mode	0,5 kV (peak) 5/50 ns Tr/Td 5 kHz repetition frequency	IEC 61000-4-4
Applicable only to ports interfacing with cables whose total length can exceed 3 m according to the manufacturer's functional specification		

Input and output d.c. power ports

Environmental phenomenon	Test specifications	Test set-up
Fast transients common mode	0,5 kV (peak) 5/50 ns Tr/Td 5 kHz repetition frequency	IEC 61000-4-4
Not applicable to input ports intended for connection to a battery or a rechargeable battery which shall be removed or disconnected from the apparatus for recharging. Apparatus with a d.c. power input port intended for use with an a.c. - d.c. power adaptor shall be tested on the a.c. power input of the a.c.- d.c. power adaptor specified by the manufacturer or, where none is so specified, using a typical a.c. - d.c. power adaptor. For d.c. input and output ports intended to be connected permanently, the test is only applicable to cables longer than 3 m.		

Input and output a.c. power ports

Environmental phenomenon	Test specifications	Test set-up
Fast transients common mode	1 kV (peak) 5/50 ns Tr/Td 5 kHz repetition frequency	IEC 61000-4-4
For extra low voltage a.c. ports and output a.c. ports, this testing is only applicable to ports interfacing with cables whose total length may exceed 3 m according to the manufacturer's functional specification.		

Performance criterion: **B**

6.2.2. Test setup

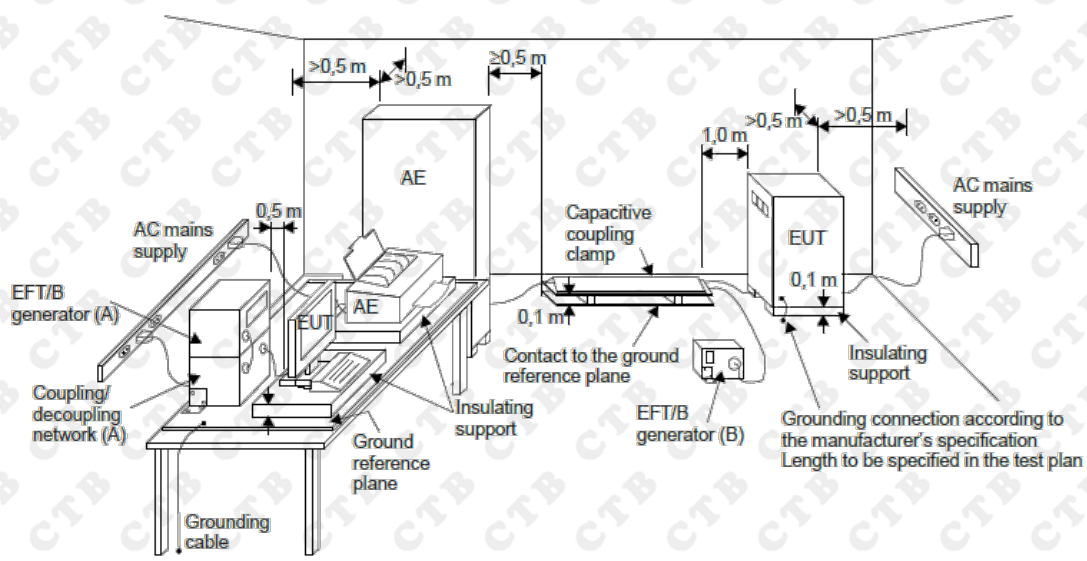

6.2.3. Test Procedure

Measurement was performed in shielded room.

Measurement procedure was applied according to EN 61000-4-4 clause 8.

The test methods and equipment were specified by EN 61000-4-4.

6.2.4. Test Result

N/A

Location	Level (kV)	Polarity (P/N)	Result
AC power input ports	1	P/N	N/A
DC power input ports	0,5	P/N	N/A
Analogue/digital data ports	0,5	P/N	N/A

6.3. Injected currents

6.3.1. Injected currents, 0,15 MHz to 230 MHz

6.3.1.1. Test Levels and Performance Criterion

Ports for signal lines and control lines

Environmental phenomenon	Test specifications	Test set-up
RF current common mode 1 kHz, 80 % AM	0,15 MHz to 230 MHz 1 V (r.m.s.) (unmodulated) 150 Ω source impedance	IEC 61000-4-6
Applicable only to ports interfacing with cables whose total length may exceed 3 m according to the manufacturer's functional specification.		

Input and output d.c. power ports

Environmental phenomenon	Test specifications	Test set-up
RF current common mode 1 kHz, 80 % AM	0,15 MHz to 230 MHz 1 V (r.m.s.) (unmodulated) 150 Ω source impedance	IEC 61000-4-6
Not applicable to battery operated appliances that cannot be connected to the mains while in use.		
Not applicable to input ports intended for connection to a battery or a rechargeable battery which shall be removed or disconnected from the apparatus for recharging. Apparatus with a d.c. power input port intended for use with an a.c. - d.c. power adaptor shall be tested on the a.c. power input of the a.c.- d.c. power adaptor specified by the manufacturer or, where none is so specified, using a typical a.c. - d.c. power adaptor. For d.c. input and output ports intended to be connected permanently, the test is only applicable to cables longer than 3 m.		

Input and output a.c. power ports

Environmental phenomenon	Test specifications	Test set-up
RF current common mode 1 kHz, 80 % AM	0,15 MHz to 230 MHz 3 V (r.m.s.) (unmodulated) 150 Ω source impedance	IEC 61000-4-6
For extra low voltage a.c. ports and output a.c. ports, this testing is only applicable to ports interfacing with cables whose total length may exceed 3 m according to the manufacturer's functional specification.		

Performance criterion: **A**

6.3.1.2. Test setup

using CDN injection devices

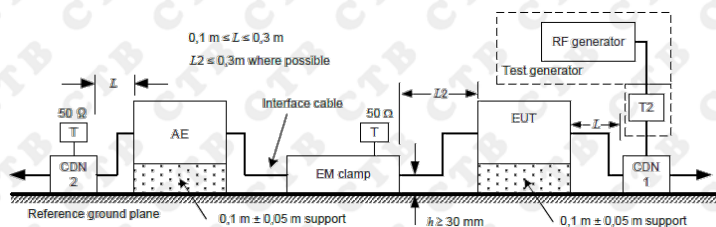

using clamp injection devices

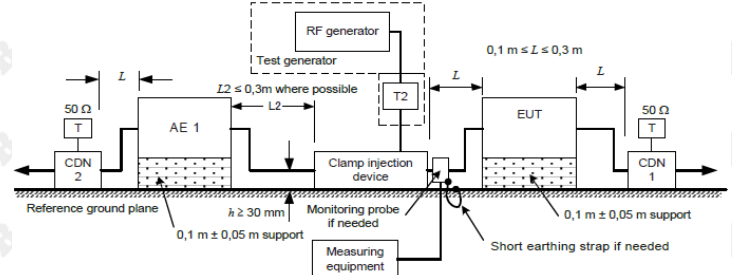

6.3.1.3. Test Procedure

Measurement was performed in shielded room.

Measurement procedure was applied according to EN 61000-4-6 clause 8.

The test methods and equipment were specified by EN 61000-4-6.

6.3.1.4. Test Result

N/A

Injected point	Frequency (MHz)	Level (e.m.f)	Modulation	Result
Signal lines and control lines	0.15 to 230	1V (r.m.s)	80%, 1 kHz, AM	N/A
d.c. power ports	0.15 to 230	1V (r.m.s)	80%, 1 kHz, AM	N/A
a.c. power ports	0.15 to 230	3V (r.m.s)	80%, 1 kHz, AM	N/A

6.3.2. Injected currents, 0,15 MHz to 80 MHz

6.3.2.1. Test Levels and Performance Criterion

Ports for signal lines and control lines

Environmental phenomenon	Test specifications	Test set-up
RF current common mode 1 kHz, 80 % AM	0,15 MHz to 80 MHz 1 V (r.m.s.) (unmodulated) 150 Ω source impedance	IEC 61000-4-6
Applicable only to ports interfacing with cables whose total length may exceed 3 m according to the manufacturer's functional specification.		

Input and output d.c. power ports

Environmental phenomenon	Test specifications	Test set-up
RF current common mode 1 kHz, 80 % AM	0,15 MHz to 80 MHz 1 V (r.m.s.) (unmodulated) 150 Ω source impedance	IEC 61000-4-6
Not applicable to battery operated appliances that cannot be connected to the mains while in use.		
Not applicable to input ports intended for connection to a battery or a rechargeable battery which shall be removed or disconnected from the apparatus for recharging. Apparatus with a d.c. power input port intended for use with an a.c. - d.c. power adaptor shall be tested on the a.c. power input of the a.c.- d.c. power adaptor specified by the manufacturer or, where none is so specified, using a typical a.c. - d.c. power adaptor. For d.c. input and output ports intended to be connected permanently, the test is only applicable to cables longer than 3 m.		

Input and output a.c. power ports

Environmental phenomenon	Test specifications	Test set-up
RF current common mode 1 kHz, 80 % AM	0,15 MHz to 80 MHz 3 V (r.m.s.) (unmodulated) 150 Ω source impedance	IEC 61000-4-6
For extra low voltage a.c. ports and output a.c. ports, this testing is only applicable to ports interfacing with cables whose total length may exceed 3 m according to the manufacturer's functional specification.		

Performance criterion: **A**

6.3.2.2. Test setup

using CDN injection devices

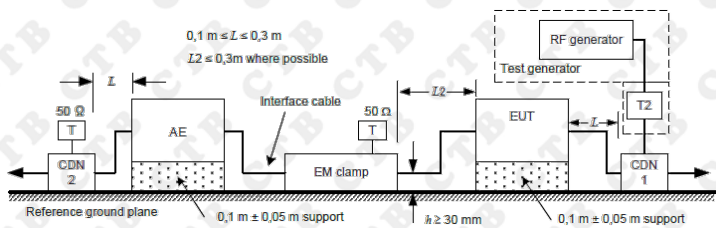

using clamp injection devices

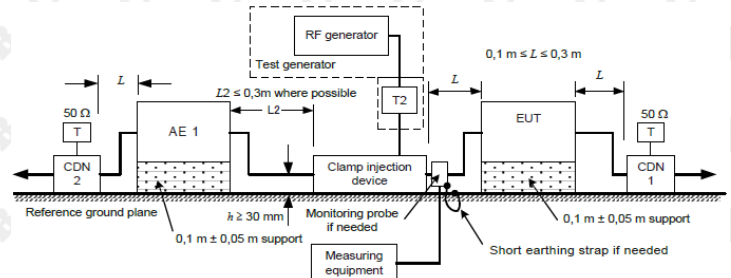

6.3.2.3. Test Procedure

Measurement was performed in shielded room.

Measurement procedure was applied according to EN 61000-4-6 clause 8.

The test methods and equipment were specified by EN 61000-4-6.

6.3.2.4. Test Result

N/A

6.4. Radio frequency electromagnetic fields, 80 MHz to 1 000 MHz

6.4.1. Test Levels and Performance Criterion

Enclosure port

Environmental phenomenon	Test specifications	Test set-up
Radio-frequency electromagnetic field, 1 kHz, 80% AM	80 MHz to 1 000 MHz 3 V/m (r.m.s.) (unmodulated)	IEC 61000-4-3 or IEC 61000-4-22

Performance criterion: **A**

6.4.2. Test setup

For table-top equipment

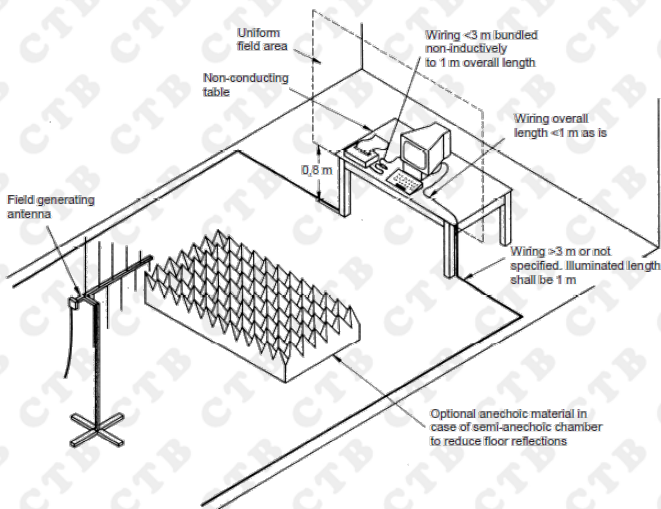

For floor standing equipment

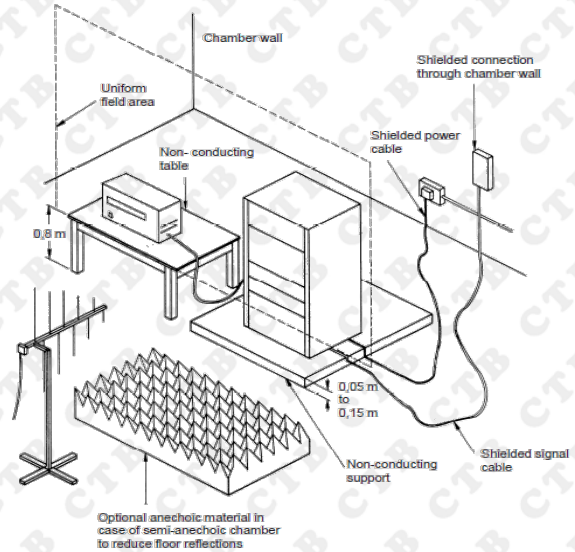

6.4.3. Test Procedure

Measurement procedure was applied according to EN 61000-4-3 clause 8. The test methods and equipment were specified by EN 61000-4-3.

6.4.4. Test Result

pass

Test results for radiated electromagnetic field						
Frequency range [MHz]	Test Level [V/m]	Polarization	EUT Face	Required Criterion	Performance Criterion	Results
80 to 1000	3	H & V	Front	A	A	PASS
			Rear	A	A	PASS
			Right	A	A	PASS
			Left	A	A	PASS
H = Horizontal V = Vertical						
Supplementary information:						

6.5. Surges

6.5.1. Test Levels and Performance Criterion

Input a.c. power ports

Environmental phenomenon	Test specifications	Test set-up
Surge	1,2/50 (8/20) μ s Tr/Td 2 kV line-to-earth with 12 Ω Impedance 1 kV line-to-line with 2 Ω Impedance	IEC 61000-4-5

Performance criterion: **B**

6.5.2. Test setup

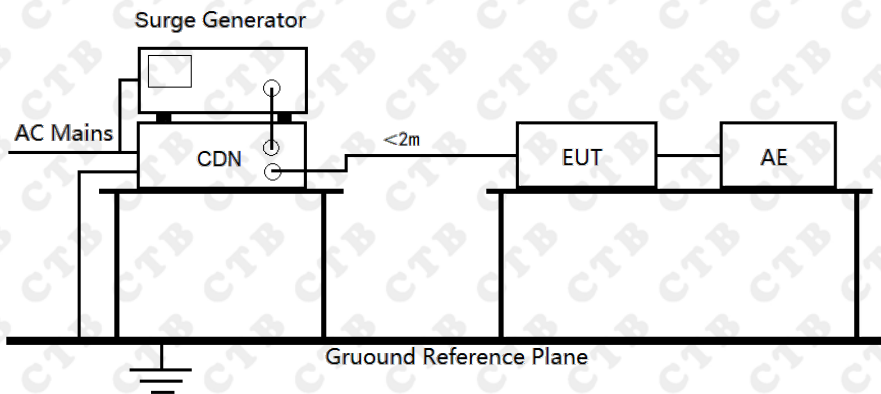

6.5.3. Test Procedure

Measurement procedure was applied according to EN 61000-4-5 clause 8. The test methods and equipment were specified by EN 61000-4-5.

6.5.4. Test Result

N/A

EUT not applicable to this test.

Location	Level(kV)	Polarity(P/N)	Result
AC mains power ports (line to line)	1.0	P/N	N/A
AC mains power ports (line to earth)	2.0	P/N	N/A
DC network power ports (line to line)	0,5	P/N	N/A
DC network power ports (line to earth)	0,5	P/N	N/A
unshielded symmetrical ports (line to ground)	1.0/4.0	P/N	N/A
coaxial or shielded ports (shield to ground)	0,5	P/N	N/A

6.6. Voltage dips

6.6.1. Test Levels and Performance Criterion

Input a.c. power ports

Environmental phenomena		Test level in % U_T	Durations for voltage dips		Test set-up
			50Hz	60Hz	
Voltage dips in %	100	0	0,5 cycle	0,5 cycle	IEC 61000-4-11 Voltage change shall occur at zero crossing
	60	40	10 cycle	12 cycle	
U_T	30	70	25 cycle	30 cycle	

U_T is the rated voltage of the equipment under test.

Performance criterion: **B&C**

6.6.2. Test setup

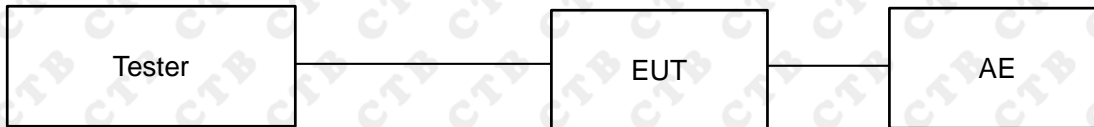

6.6.3. Test Procedure

Measurement procedure was applied according to EN 61000-4-11 clause 8.

The test methods and equipment were specified by EN 61000-4-11.

6.6.4. Test Result

N/A

EUT not applicable to this test.

U_T in V	Frequency in Hz	Test Level % of U_T	Phase angles [°]	Duration in cycles	Results
<input checked="" type="checkbox"/> 230 <input type="checkbox"/> 120	<input checked="" type="checkbox"/> 50 <input type="checkbox"/> 60	0	0, 45, 90, 135, 180, 225, 270, 315	<input checked="" type="checkbox"/> 0,5 (50 Hz) <input type="checkbox"/> 0,5 (60 Hz)	N/A
<input checked="" type="checkbox"/> 230 <input type="checkbox"/> 120	<input checked="" type="checkbox"/> 50 <input type="checkbox"/> 60	40	0, 45, 90, 135, 180, 225, 270, 315	<input checked="" type="checkbox"/> 25 (50 Hz) <input type="checkbox"/> 30 (60 Hz)	N/A
<input checked="" type="checkbox"/> 230 <input type="checkbox"/> 120	<input checked="" type="checkbox"/> 50 <input type="checkbox"/> 60	70	0, 45, 90, 135, 180, 225, 270, 315	<input checked="" type="checkbox"/> 250 (50 Hz) <input type="checkbox"/> 300 (60 Hz)	N/A

7. Photographs of test setup

Photograph of test setup for Radiated Emission



8. Photographs of EUT



Photographs of EUT

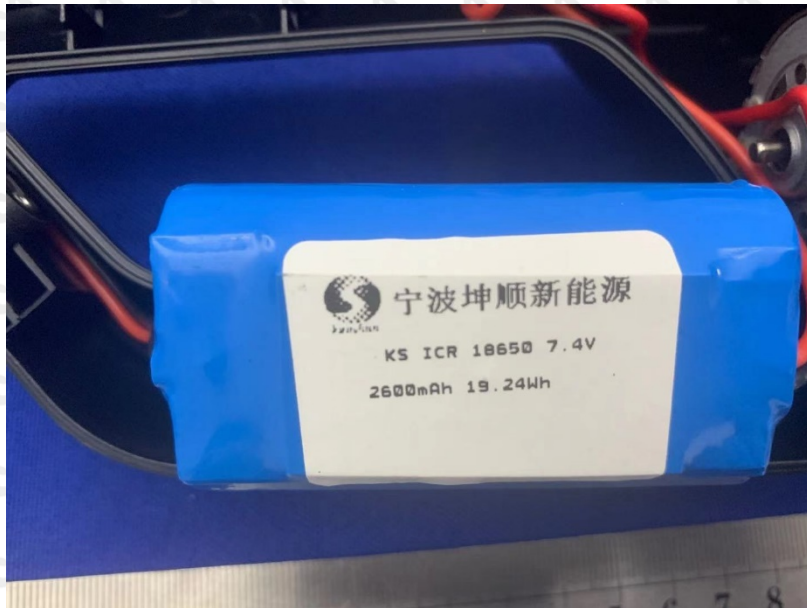
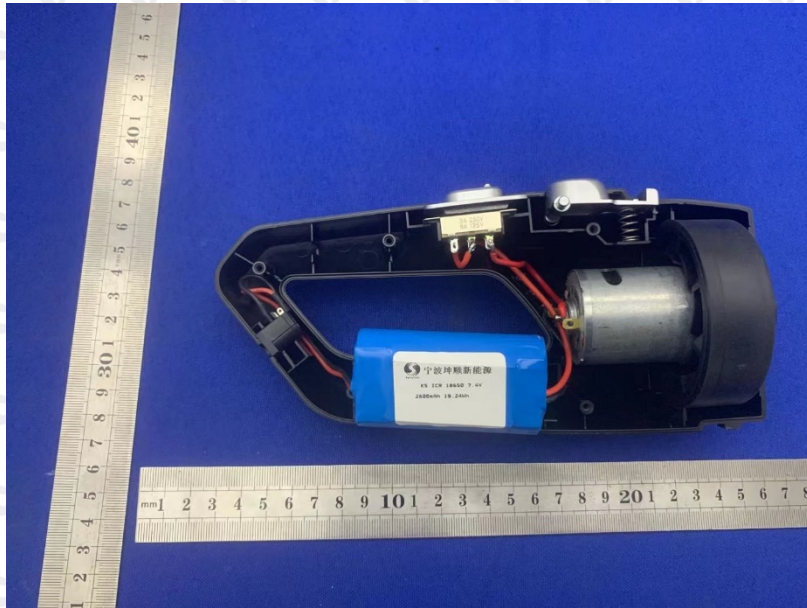

Photographs of EUT

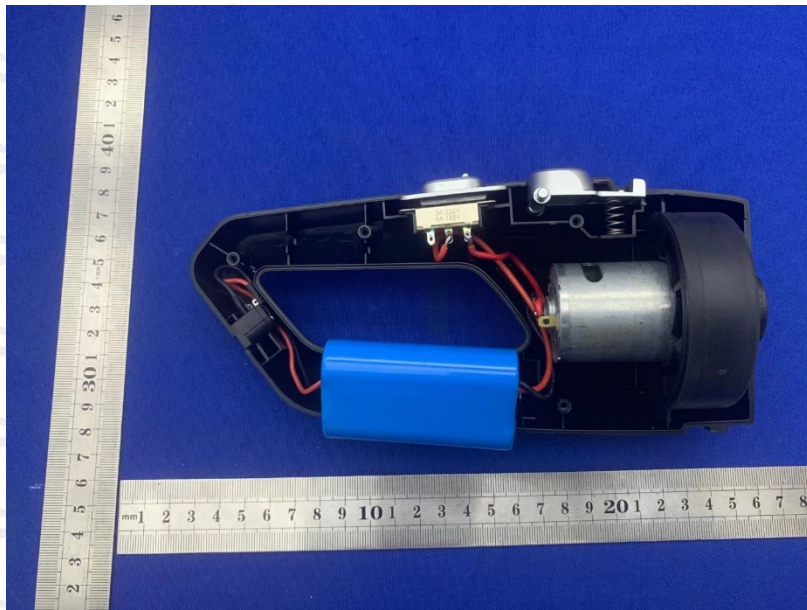

End of report