



EN IMPORTANT - Please read carefully the separate safety guide before use.

FR IMPORTANT - Lire attentivement le guide de sécurité séparé avant utilisation.

PL WAŻNE - Przed użyciem proszę dokładnie zapoznać się z instrukcją bezpieczeństwa.

DE WICHTIG - Bitte lesen sie die separaten sicherheitsanweisungen vor gebrauch.

RUS ВАЖНО - Пожалуйста, внимательно прочитайте отдельное руководство по технике безопасности перед использованием.

RO IMPORTANT - Vă rugăm să citiți cu atenție ghidul de siguranță separat înainte de utilizare.

ES IMPORTANTE - Lea atentamente la guía de seguridad separado antes de utilizar.

PT IMPORTANTE - Leia atentamente a guia de segurança separado antes de usar.

TR ÖNEMLI - Kullanmadan önce emniyet kurallarını lütfen dikkatle okuyun.

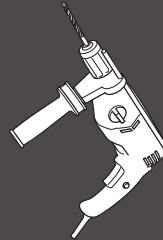
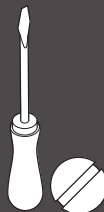
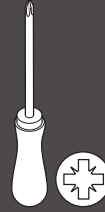
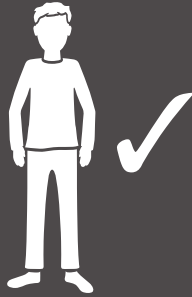

PTFE

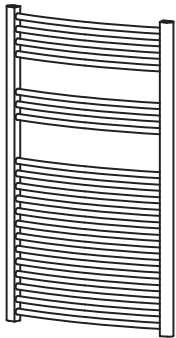

[01] x1

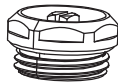

[02] x1



[03] x1

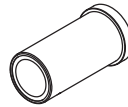

[04] x4



[05] x4



[06] x4



[07] x4



[08] x4



[09] x4



[10] x4



[11] x4



[12] x4

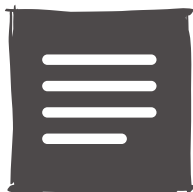

- EN Curved ladder towel warmer
- DE Sprossenhandtuchtrockner, gewölbt
- ES Radiador toallero de agua curvado
- RO Radiator de baie portprosop curbat
- TR Eğri merdiven tipi havlu isitici

- FR Sèche-serviettes à tubes galbés
- RUS Изогнутый полотенцесушитель лестничного типа
- PT Radiador toalheiro de água curvado
- PL Grzejnik łazienkowy drabinkowy zaokrąglony



- EN Preparation
- DE Vorbereitung
- ES Preparación
- FR Préparation
- RUS Подготовка
- PT Preparação
- PL Przygotowanie
- RO Pregătire
- TR Hazırlık

EN Preparation

- Please check that all components are present and that you are ENTIRELY happy with the size, design and finish before starting installation.
- If there are any missing or damaged parts, please contact the supplier immediately.
- Radiator should be installed using brackets supplied.
- Fixings supplied are for use in solid wall connections, if connecting to hollow walls (e.g.plasterboard) where possible fix to internal timbers, or ensure appropriate fixings are used.
- When drilling or fixing into walls, floors or ceilings it is essential that you check for any pipes & wires before commencing.
- Plastic caps on each threaded connection of the radiator should be removed and disposed of before installation.
- Ensure that the radiator is positioned in order that it can be easily connected to the central heating system.

FR Préparation

- Veuillez vérifier que tous les composants sont présents et que la taille vous satisfait ENTièrement avant de commencer l'installation.
- S'il y a des pièces manquantes ou endommagées, veuillez contacter immédiatement le fournisseur.
- Le radiateur doit être installé à l'aide des supports fournis.
- Les fixations fournies sont destinées à être utilisées sur des connexions murales solides. Si elles sont reliées à des parois creuses (comme des plaques de plâtre), assurez-vous si possible qu'elles soient fixées sur des bois intérieurs ou avec des fixations appropriées.
- Lors du perçage ou de la fixation dans les murs, les planchers ou les plafonds, il est essentiel de vérifier s'il y a des tuyaux ou des câbles dissimulés avant de commencer.
- Les bouchons en plastique sur chaque raccord fileté du radiateur doivent être enlevés et jetés avant l'installation.
- Assurez-vous que le radiateur est positionné de telle sorte qu'il puisse être facilement connecté au système de chauffage central.

PL Przygotowanie

- Przed rozpoczęciem instalacji sprawdź, czy wszystkie elementy są dostępne i czy jesteś CAŁKOWICIE zadowolony z rozmiaru, konstrukcji i wykończenia.
- Jeśli brakuje jakichś części lub części są uszkodzone, należy niezwłocznie skontaktować się z dostawcą.
- Grzejnik powinien być zainstalowany przy użyciu dostarczonych wsporników.
- Mocowania dostarczane są do stosowania w połączeniach ścian litych. Przy mocowaniu do pustych ścian (np. gipsowo-kartonowych) należy wykorzystać w miarę możliwości wewnętrzne wzmocnienia z drewna lub zastosować odpowiednie mocowanie.
- Przed rozpoczęciem wiercenia lub mocowania w ścianach, podłodze lub suficie, konieczne jest sprawdzenie położenia wszelkich rur i przewodów.
- Plastikowe nakładki na każdej gwintowanej złączce grzejnika powinny być usunięte i zutylizowane przed instalacją.
- Upewnij się, że grzejnik jest umieszczony tak, aby można go było łatwo podłączyć do systemu centralnego ogrzewania.

DE Vorbereitung

- Bitte überprüfen Sie vor Beginn der Installation, ob alle Teile vorhanden sind und Sie VÖLLIG zufrieden mit der Größe und dem Design des Heizkörpers sind.
- Bei fehlenden Teilen oder Beschädigungen kontaktieren Sie bitte umgehend den Lieferanten.
- Der Heizkörper ist mithilfe des im Lieferumfang enthaltenen Installationszubehörs zu installieren.
- Das mitgelieferte Installationszubehör sieht die Installation an massiven Wänden vor. Bei hohlen Wänden (z.B. Trockenbauwand) ist der Heizkörper, soweit möglich, an innen liegenden Holzbalken anzubringen bzw. es ist anderes geeignetes Installationszubehör zu verwenden.
- Beim Bohren in Wände, Böden oder Decken ist es wichtig, dass Sie vorher prüfen, ob dort Leitungen oder Kabel verlaufen.
- Die Kunststoffkappen auf den Gewindeanschlüssen des Heizkörpers sind vor der Installation zu entfernen und entsorgen.
- Stellen Sie sicher, dass der Heizkörper so positioniert ist, dass er einfach an die zentrale Heizungsanlage angeschlossen werden kann.

RUS Подготовка

- Перед началом установки проверьте наличие всех деталей и убедитесь, что Вам ПОЛНОСТЬЮ подходит размер, конструкция и внешний вид радиатора.
- При обнаружении недостающих или поврежденных деталей, немедленно обратитесь к поставщику.
- При установке радиатора следует использовать только поставляемые в комплекте кронштейны.
- Поставляемые в комплекте крепления предназначены для массивных стен. При креплении к пустотным стенам (например, из гипсокартона) по возможности производите крепление к внутренним балкам или используйте подходящие для подобных стен крепления.
- При сверлении или креплении к стенам, полу или потолку, перед началом работы обязательно проверьте прокладку проводки и труб.
- Пластмассовые колпачки на каждом резьбовом соединении радиатора перед установкой необходимо снять и утилизировать.
- Убедитесь в том, что радиатор располагается таким образом, что его легко можно подключить к системе центрального отопления.

RO Pregătire

- Vă rugăm să verificați că toate componentele sunt prezente și că sunteți în TOTALITATE mulțumit de dimensiunea, design-ul și finisajul produsului, înainte de a începe instalarea.
- În cazul în care există piese lipsă sau deteriorate, vă rugăm să contactați imediat furnizorul.
- Radiatorul trebuie să fie instalat utilizând suporturile furnizate.
- Elementele de fixare furnizate sunt destinate conexiunilor pe perete solid, iar în cazul conectării la pereți poroși (ex.gips-carton), unde este posibil, trebuie să se fixeze în grinzile de lemn interne, sau asigurați-vă că sunt utilizate elemente de prindere corespunzătoare.
- La găurirea sau fixarea în pereți, pardoseli sau tavane, este esențial să verificați dacă există țevi și cabluri înainte de a începe.
- Capacele din plastic de pe fiecare record filetat al radiatorului trebuie să fie îndepărtate și eliminate înainte de instalare.
- Asigurați-vă că radiatorul este poziționat astfel încât acesta să poate fi conectat cu ușurință la sistemul de încălzire centrală.

ES Preparación

- Compruebe que estén presentes todos los componentes y que está TOTALMENTE satisfecho con el tamaño, el diseño y el acabado antes de empezar con la instalación.
- Si alguna pieza falta o está dañada, póngase en contacto inmediatamente con el proveedor.
- El radiador debe instalarse utilizando los soportes incluidos.
- Los elementos de sujeción incluidos son para el uso en paredes macizas. Si lo va a instalar en paredes huecas (por ejemplo, cartón yeso), siempre que sea posible sujételo a maderas internas, o asegúrese de utilizar elementos de sujeción apropiados.
- Cuando taladre o sujete a paredes, suelos o techos, es esencial que compruebe la presencia de tuberías o cables antes de empezar.
- Hay que quitar las caperuzas de plástico de cada conexión roscada del radiador y eliminarlas antes de la instalación.
- Asegúrese de que el radiador esté colocado de modo que se pueda conectar fácilmente al sistema de calefacción central.

PT Preparação

- Certifique-se de que tem todos os componentes e que está COMPLETAMENTE contente com o tamanho, design e acabamento antes de iniciar a instalação.
- Se houver peças danificadas ou em falta, contacte imediatamente o fornecedor.
- O radiador deverá ser instalado usando os suportes fornecidos.
- Os fixadores fornecidos são para ser usados em ligações de paredes sólidas. Se efetuar a ligação em paredes ocas (como placa de estuque), sempre que possível, fixe nas vigas de madeira internas, ou certifique-se de que usa os fixadores adequados.
- Quando perfurar ou fixar em paredes, pisos ou tetos, é essencial verificar se existem tubagens ou cablagens antes de começar.
- Deverá retirar e eliminar as tampas de plástico em cada ligação roscada do radiador antes da instalação.
- Certifique-se de que o radiador está posicionado de modo a ser facilmente ligado ao sistema de aquecimento central.

TR Hazırlık

- Lütfen montaja başlamadan önce tüm parçaların mevcut olduğundan ve boyutu, tasarımı ve görünümünden TAMAMEN memnun olduğunuzdan emin olun.
- Herhangi bir eksik veya hasarlı parça varsa lütfen hemen tedarikçi ile irtibat kurun.
- Radyatör verilen braketter kullanılarak monte edilmelidir.
- Verilen bağlantı parçaları sert duvar bağlantılarında kullanılmak içindir, içi boş duvarlara (ör. alçıpan) bağlayacaksanız iç kırırlere monte edin ya da uygun bağlantı parçalarının kullanılmasını sağlayın.
- Duvara, yere veya tavana montaj yaparken veya delerken, başlamadan önce kablo ve boruların olup olmadığını kontrol etmeniz gerekir.
- Radyatörün her dişli bağlantısındaki plastik başlıklar çıkarılmalı ve montajdan önce bertaraf edilmelidir.
- Radyatörün merkezi ısıtma sistemine kolayca bağlanacak şekilde yerleştirilmesini sağlayın.



EN Assembly
RO Asamblare

FR Assemblage
ES Montaje

PL Montaż
PT Montagem

DE Montage
TR Kurulum

RUS Сборка

01

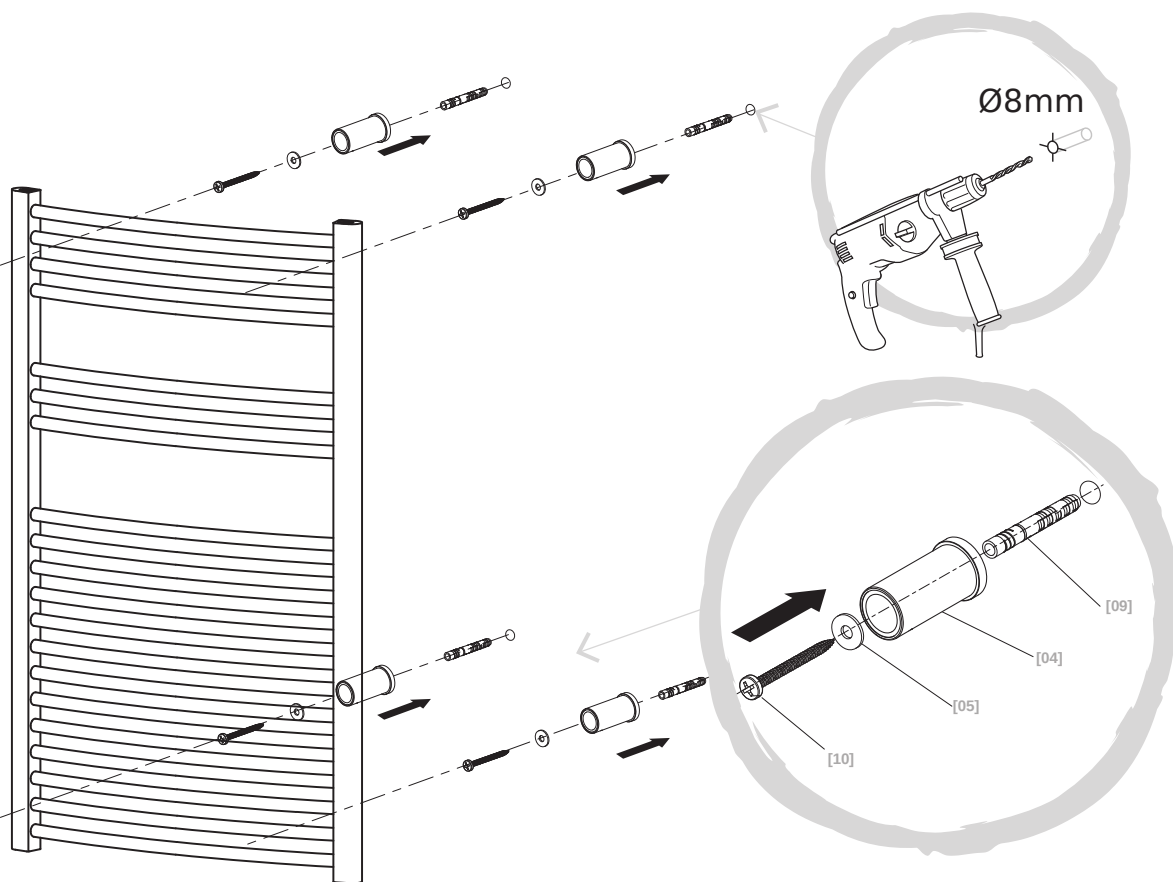

02

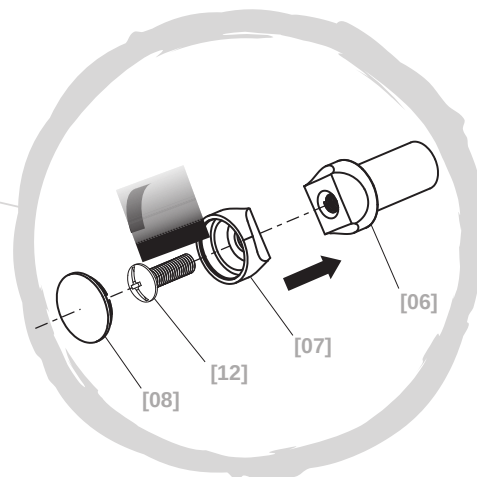
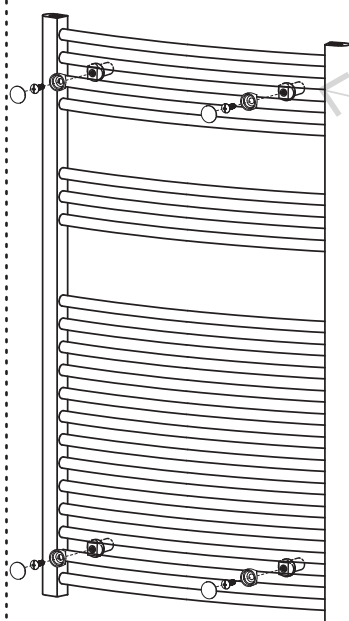

[06]

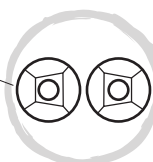

EN Curved towel rail
DE Gebogener Handtuchhalter
ES Toallero curvo
RO Bară prosop curbată
TR Eğimli havlu askılığı

FR Tube incurvé
RUS Полотенцесушитель изогнутый
PT Toalheiro curvo
PL Grzejnik łazienkowy - wykończenie zaokrąglone

03



[11] x4

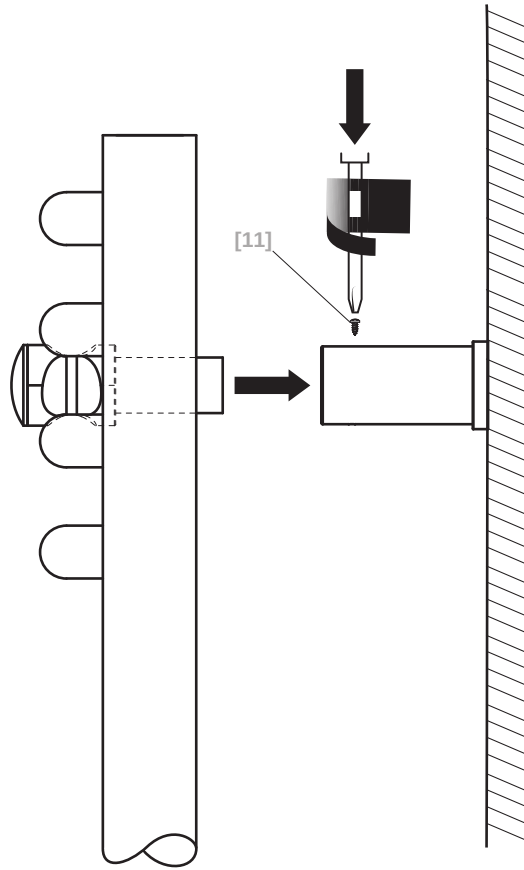

04

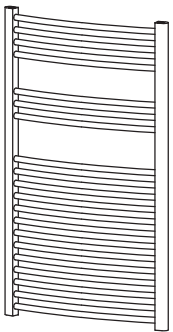

[01] x1



[02] x1



[03] x1

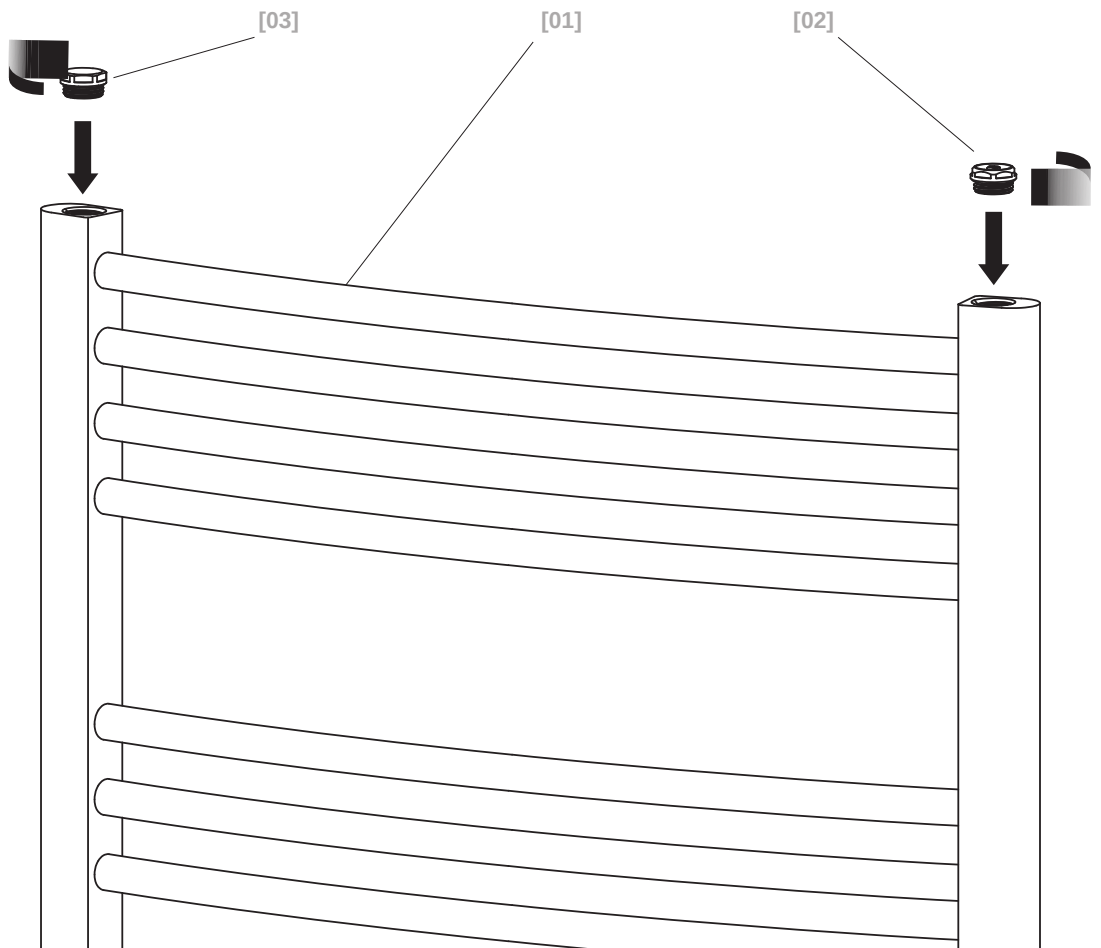

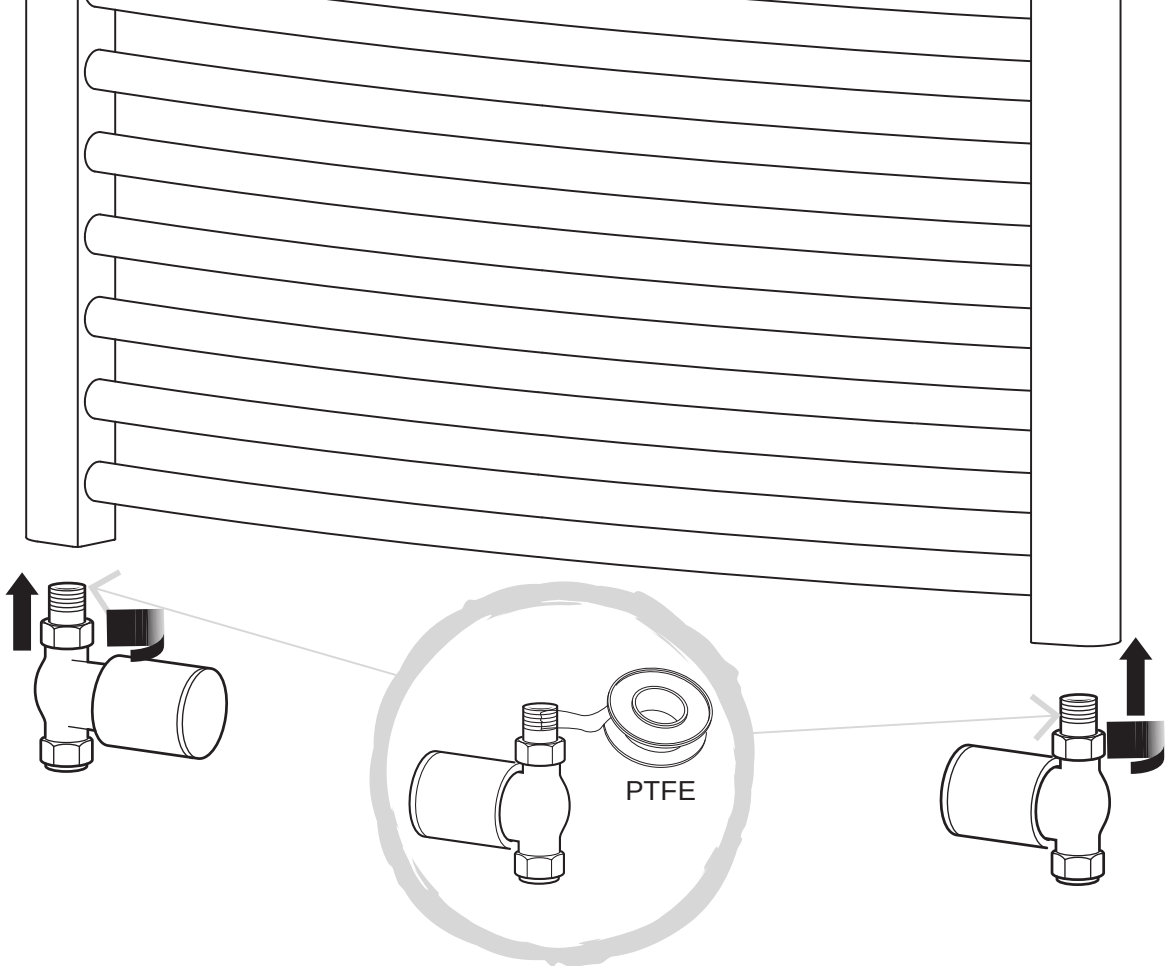

EN Not included FR Non inclus PL Nie dołączono DE Nicht inbegriffen RUS Не прилагается
RO Nu este inclus ES No incluido PT Não incluída TR Dahil değildir



EN Care & maintenance
 PL Pielęgnacja i konserwacja
 RUС Уход и обслуживание
 ES Cuidados y Mantenimiento
 TR Bakım ve Onarım

FR Entretien et maintenance
 DE Pflege und Wartung
 RO Îngrijire și întreținere
 PT Cuidados e manutenção

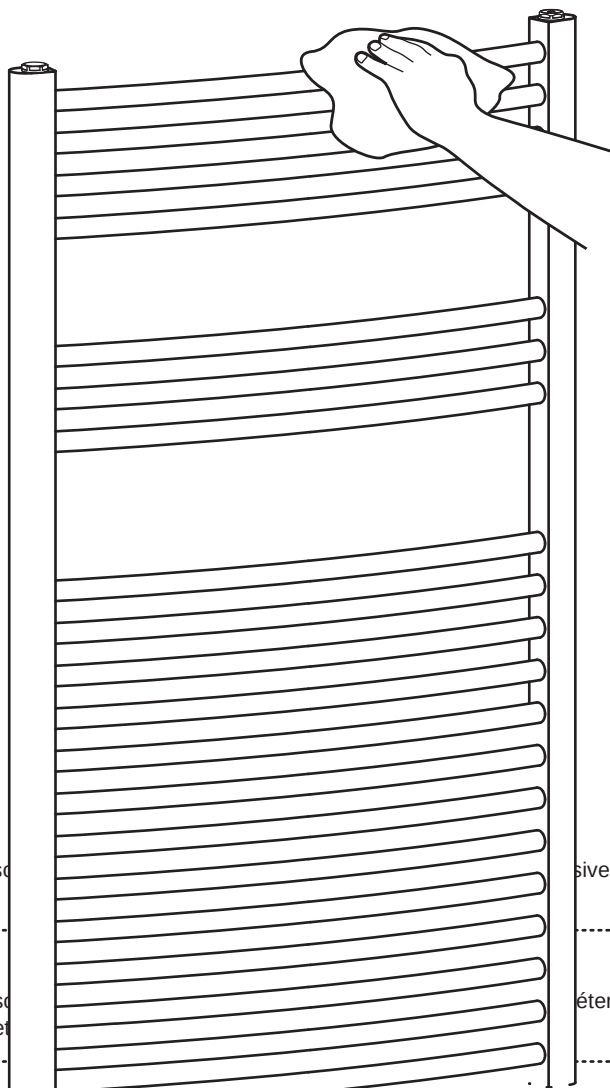
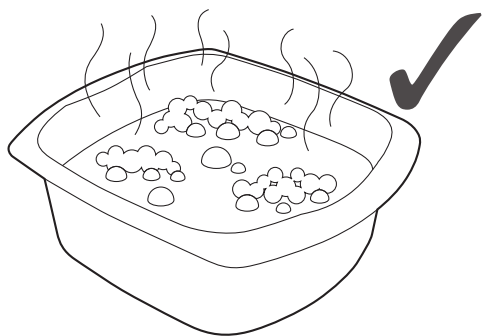
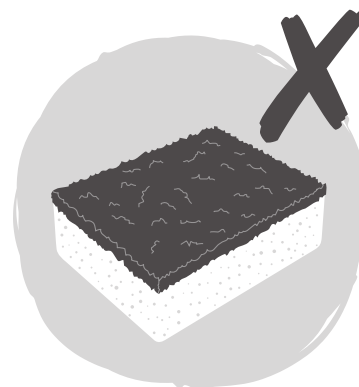
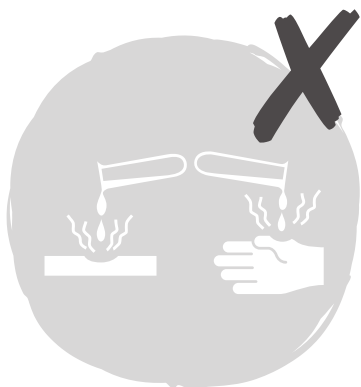

EN Care

Wipe the surface clean with a soft, damp cloth. Never use any solvents, scourers or solvent type cleaning solutions on the product.

FR Entretien

Essuyez la surface avec un chiffon doux et humide. N'utilisez jamais de solvants, nettoyeurs abrasifs, nettoyeurs chimiques agressifs ou solvant de type solutions nettoya-

PL Pielęgnacja

Przetrzyj powierzchnię miękką, wilgotną ściereczką. Do produktu nie należy używać żadnych rozpuszczalników, druciaków, proszków do czyszczenia, materiałów ściernych, środków żrących, wybielaczy, kwasów, silnych detergentów i żrących chemicznych środków czyszczących, ani też roztworów czyszczących typu rozpuszczalnikowego.

DE Pflege

Wischen Sie die Oberfläche mit einem weichen, feuchten Tuch ab. Niemals Lösungsmittel, Topfkratzer, Scheuermittel, Bleichmittel, Säuren, scharfe Reinigungsmittel, aggressive chemische Reinigungsmittel oder lösungsmittelhaltige Reiniger auf diesem Produkt verwenden.

sive chemical

étergents

RUS Уход

Протрите поверхность устройства мягкой влажной тряпкой. Никогда не используйте для очистки данного изделия какие-либо растворители, жесткие мочалки, абразивные средства, отбеливатели, кислоты, сильные чистящие средства, агрессивные химические очистители или моющие средства на основе растворителей.

RO Îngrijire

Ștergeți suprafața cu o cârpă moale, umedă. Nu utilizați niciodată solvenți, bureți abrazivi, produse de curățat abrazive, înălbitor, acizi, detergenți, produse de curățat chimice agresive sau soluții de curățat de tip solvenți pe acest produs.

ES Cuidados

Limpie la superficie con un paño suave humedecido. No utilice nunca disolventes, estropajos, productos abrasivos, lejía, ácidos, detergentes, limpiadores químicos agresivos ni soluciones de limpieza de tipo disolvente en el producto.

PT Cuidados

Limpe a superfície com um pano suave ligeiramente embebido em água. Nunca use solventes, esfregões, produtos de limpeza abrasivos, lixívia, ácidos, detergentes fortes, produtos de limpeza químicos agressivos ou soluções de limpeza do tipo solvente no produto.

TR Bakım

Yüzeyini yumuşak, nemli bir bezle silerek temizleyin. Asla üründe herhangi bir solvent, bulaşık teli, kazıyıcılar, çamaşır suyu, asitler, güçlü deterjanlar, aşındırıcı kimyasal temizlik maddeleri veya solvent türü temizlik solüsyonlarını kullanmayın.



RADIATEURS, CONVECTEURS
ET PANNEAUX RAYONNANTS
À EAU CHAUDE - NF 047 / 191



**Manufacturer • Fabricant • Producent •
Producător • Fabricante:**

UK Manufacturer:

Kingfisher International Products Limited,
3 Sheldon Square, London, W2 6PX,
United Kingdom

EU Manufacturer:

Kingfisher International Products B.V.
Rapenburgerstraat 175E
1011 VM Amsterdam
The Netherlands
www.kingfisher.com/products

EN

www.diy.com
www.screwfix.com
www.screwfix.ie

**To view instruction manuals online,
visit www.kingfisher.com/products**

FR

**Pour consulter les manuels d'instructions
en ligne, rendez-vous sur le site
www.kingfisher.com/products**

PL

**Aby zapoznać się z instrukcją obsługi online,
odwiedź stronę www.kingfisher.com/products**

RUS

Импортер:

ООО «Касторама РУС»
Дербеневская наб., дом 7, стр.8,
Россия, Москва, 115114
www.castorama.ru

Изготовитель для России:

Джиангси Авонфлоу ХВАК Тех Ко., Лтд.

Адрес: Ксури Ареа, Шанграо Экономик
Девелопмент Зон, Ждианси, Китай

**Онлайн-версии руководств по
эксплуатации доступны на странице
www.kingfisher.com/products**

RO

www.bricodepot.ro

**Pentru a consulta manualele de instrucțiuni
online, vizitați www.kingfisher.com/products**

ES

www.bricodepot.es

**Para consultar los manuales de instrucciones
en línea, visite www.kingfisher.com/products**

PT

www.bricodepot.pt

**Para consultar manuais de instruções online,
visite www.kingfisher.com/products**

TR

İthalatçı Firma:

KOÇTAŞ YAPI MARKETLERİ TİC. A.Ş.
Taşdelen Mah. Sırrı Çelik Bulvarı No: 5
34788 Taşdelen/Çekmeköy/İSTANBUL
Tel: +90 216 4300300
Faks: +90 216 4844313
www.koctas.com.tr

**Kullanım kılavuzuna internet üzerinden ulaşmak
için www.kingfisher.com/products adresini
ziyaret edin**

Yetkili servis istasyonları ve yedek parça temini için
aşağıda yer alan Koçtaş Müşteri Hattı ve Koçtaş
Genel Müdürlük irtibat bilgilerinden faydalanınız.

KOÇTAŞ MÜŞTERİ HİZMETLERİ
0850 209 50 50