

Automatic barrier with smartphone control feature

Automatic closing feature

Operating autonomy up to 1 year (rechargeable li-ion batteries)

Solar panel for extended autonomy

Manual control possibility

Constant power supply option (optional backup battery)

Technical characteristics

Dimensions (barrier opened):	918 mm x 331 mm x 70 mm
Dimensions (barrier closed):	453 mm x 331 mm x 517 mm
Weight:	15.2 kg
Working temperature:	-20 °C to 60 °C
Working humidity:	5 % to 95 % RH, non-condensing
Operating altitude:	2000 m
Ingress protection:	IP65
Nominal travel time:	<5 s
Power supply:	Parklio battery pack Parklio double battery pack AC/DC external low voltage power supply (constant supply)
Operating voltage:	6 Vdc – 11 Vdc
Current consumption (operation):	2 A continuous, 8 A peak current
Current consumption (standby):	100 uA average standby current
Wireless connectivity:	Bluetooth LE
Over-The-Air upgrades:	Yes
Antenna interface:	Internal 2.4 GHz antenna
Sensors:	One magnetic sensor and one Class 1 laser sensor for detecting vehicle presence
Protection and coatings:	Cold dip galvanized and lacquered, powder coated Stainless steel

Parklio Smart Parking Barrier technical data

Transmission power:	4 dBm
RF Power Accuracy:	±2.5 dB
Receiver sensitivity:	-96 dBm
Frequency range:	2402 MHz to 2480 MHz
Adv. interval:	211 ms

BLE radio performance

Nominal voltage:	7.4 V
Battery charging voltage:	8.4 V
Typ. capacity:	3200 mAh (single) / 6400 mAh (double)
Discharge temperature:	-20 °C to 60 °C
Charging temperature:	0 °C to 40 °C
Charger input voltage:	9V (single) / 12V (double)
Charging current:	700 mA (single) / 1500mA (double)
Protection:	Input short circuit protection Input reverse polarity protection Charging over-temperature protection Charging over-voltage protection Output over-current protection Output short-circuit protection

Battery pack specifications

Input voltage:	85 Vac to 264 Vac
Input voltage frequency:	47 Hz to 63 Hz
Efficiency:	83 %
Input current:	1.2 A (115 Vac) 0.8A (230 Vac)
Inrush current:	30A (115 Vac) 60A (230 Vac)
Output voltage:	10.8 Vdc - 13.8 Vdc
Continuous output current:	4.5 A
Rated power:	54 W
No load power:	0.3 W
Output ripple voltage:	120 mVpp
Operational temperature:	-30 °C to 70 °C
Operational humidity:	20 % to 90 %, non-condensing
Operational altitude:	2000 m
Protection:	Over voltage Current limiting Overload Short circuit Overcurrent
Dimensions:	52.5 mm x 90 mm x 54.5 mm
Mounting:	DIN rail

External AC/DC Power supply specifications

Overall dimensions

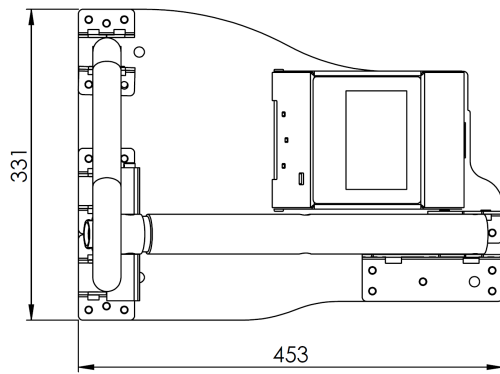

Barrier Raised - Top View

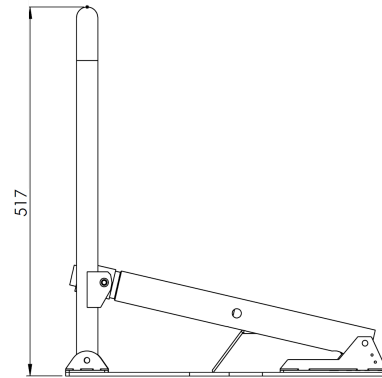

Barrier Raised - Side View

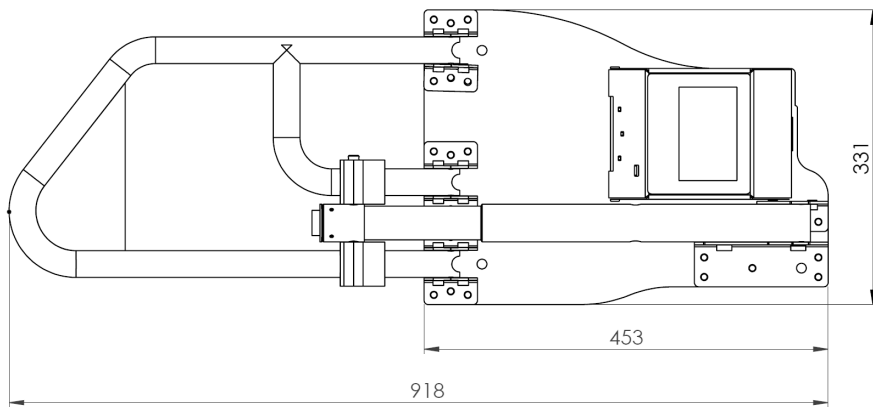

Barrier Lowered - Top View

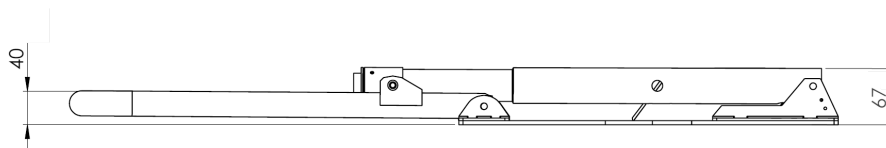

Barrier Lowered - Side View

Attention!

- Please read the user manual and technical sheet before using the Parklio smart parking barrier.
- Only use Parklio battery packs with the barrier.
- Only use the Parklio provided AC/DC power supply with the barrier.

