















# **BEER TOWER**



# BEER TOWER

 <p>tap beer tower Model: DTPJT</p>	 <p>tap beer tower Model: DTPJT</p>	 <p>tap beer tower Model: DTPJT</p>
 <p>CGA320 gas regulator D coupler Model: 1TJZQBFPQGZ-D-US</p>	 <p>W21.8 gas regulator S coupler Model: TJZQBFPQGZ-S-EU</p>	 <p>W21.8 gas regulator A coupler Model: TJZQBFPQGZ-A-EU</p>
 <p>CGA320 gas regulator D coupler Model: 1TJZQBFPQGZ-D-US</p>	 <p>W21.8 gas regulator S coupler Model: TJZQBFPQGZ-S-EU</p>	 <p>W21.8 gas regulator A coupler Model: TJZQBFPQGZ-A-EU</p>

<p>CGA320 gas regulator D coupler Model: 2TJZQBFPQGZ-D-US</p>	<p>W21.8 gas regulator S coupler Model: 2TJZQBFPQGZ-S-EU</p>	<p>W21.8 gas regulator A coupler Model: 2TJZQBFPQGZ-A-EU</p>
 <p>CGA320 gas regulator D coupler Model: 1TJZQBFPQGGZDSP- D-US</p>	 <p>W21.8 gas regulator S coupler Model: 1TJZQBFPQGGZDSP-S-E U</p>	 <p>W21.8 gas regulator A coupler Model: 1TJZQBFPQGGZDSP- A-EU</p>
 <p>CGA320 gas regulator D coupler Model: 2TJZQBFPQGGZDSP- D-US</p>	 <p>W21.8 gas regulator S coupler Model: 2TJZQBFPQGGZDSP-S-E U</p>	 <p>W21.8 gas regulator A coupler Model: 2TJZQBFPQGGZDSP- A-EU</p>



Warning-To reduce the risk of injury, user must read instructions manual carefully.



This product is subject to the provision of European Directive 2012/19/EC. The symbol showing a wheeled bin crossed through indicates that the product requires separate refuse collection in the European Union. This applies to the product and all accessories marked with this symbol. Products marked as such may not be discarded with normal domestic waste, but must be taken to a collection point for recycling electrical and electronic devices

# Connect beer tower with accessories as following image





## How to Install the Beer Tower Kit



Remove the cover, place the gasket.



Insert tubes through the hole.



Attach the tower with screws.



Install springs and faucet, tighten the collar counterclockwise with a wrench.



Screw the beer line hexnut onto the coupler.



Push air line onto coupler and tighten clamp.







## Notes of gas regulator



All valves of co2 regulator must be closed before using



Connect the keg regulator to the gas tank with a wrench



Open CO2 tank slowly



Set keg pressure by turning pressure adjustment knob towards "+" slowly



Attach hose and turn on the ON/OFF knob to let the gas flow to keg



Pull the pressure relief valve ring to release excess pressure

The handles on this system keep getting stuck. How to fix this?

Sticking faucets are a common problem in home draft systems, especially when they are not used often. Disconnecting the draft system and running the faucets under hot water for a few seconds usually does the trick. Also

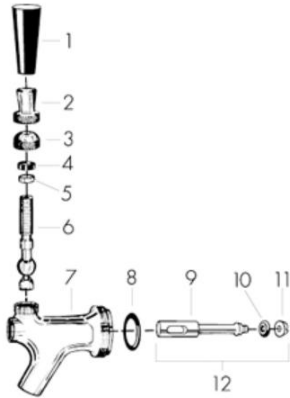

spraying the front of the faucets with water can help as well, essentially beer dries in the front portion of the faucet causing it to stick, beer is very sticky when dry but water breaks it down pretty easily.

I cant get anything other than foam, is there a problem with my settings?

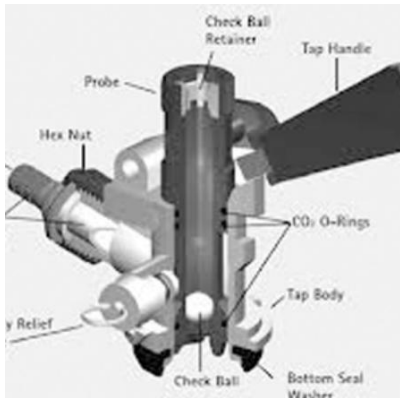

High Co2 Pressure: We normally recommend 10~12 pounds. Pull the relief valve on the coupler and adjust output up as you are pouring.  
 Beer Lines: Beer lines longer than 6 feet can cause issues. After long use, please use our cleaning kit to ensure that the lines are free from dirty.  
 Coupler Probe Washer: If it is damaged or missing, you will always get foam beer.  
 Poor pour: Hold the glass 45 degrees, tilt the glass upright as you reach the halfway point.  
 Warm hose: Install a tower cooler to cool the beer hose inside the tower.

How to fix find and fix a leak in a regulator?

Get a spray bottle and fill it with foaming agent. You can also use a no-rinse sanitizer like Star San mixed with water if you are a home brewer. You just need something that will

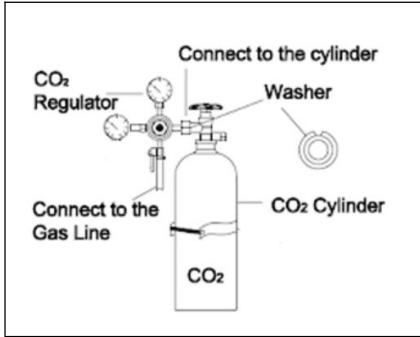

bubble up when air is escaping.  
**TIPS:** After the installation is complete, please be sure to observe the system for leaks for avoid wasting CO2.

**Manufacturer:** Shanghaimuxinmuyeyouxiangongsi

**Address:** Baoshanqu Shuangchenglu 803long 11hao 1602A-1609shi  
 Shanghai

**Imported to AUS:** SIHAO PTY LTD. 1 ROKEVA STREETEASTWOOD  
 NSW 2122 Australia

**Imported to USA:** Sanven Technology Ltd. Suite 250, 9166 Anaheim  
 Place, Rancho Cucamonga, CA 91730



Pooledas Group Ltd  
 Unit 5 Albert Edward House,  
 The Pavilions Preston, United Kingdom  
 pooledas123@gmail.com  
 01772418127



SHUNSHUN GmbH  
 Römeräcker 9 Z2021,76351  
 Linkenheim-Hochstetten, Germany  
 euvertreter@gmail.com  
 +49 1727041930

**Made In China**











# **TOUR À BIÈRE**





## BEER TOWER

 <p>tour de bière pression Modèle : DTPJT.</p>	 <p>tour de bière pression Modèle : DTPJT.</p>	 <p>tour de bière pression Modèle : DTPJT.</p>
 <p>Coupleur D de régulateur de gaz CGA320 Modèle : 1TJZQBFPQGZ-D-US</p>	 <p>Coupleur S du régulateur de gaz W21.8 Modèle : TJZQBFPQGZ-S-EU</p>	 <p>Régulateur de gaz W21.8, coupleur A Modèle : TJZQBFPQGZ-A-EU</p>



Coupleur D de  
régulateur de gaz  
CGA320 Modèle :  
2TJZQBFPQGZ-D-US



Coupleur S du régulateur  
de gaz W21.8 Modèle :  
2TJZQBFPQGZ-S-EU



Régulateur de gaz  
W21.8, coupleur A  
Modèle :  
2TJZQBFPQGZ-A-EU



Coupleur D de  
régulateur de gaz  
CGA320  
Modèle : 1TJZQBFPQ  
GZDSP-D-US



Coupleur S du régulateur  
de gaz W21.8 Modèle :  
1TJZQBFPQGZDSP-S-E  
U



Régulateur de gaz  
W21.8, coupleur A  
Modèle : 1TJZQBFPQ  
GZDSP-A-EU



Coupleur D de  
régulateur de gaz





Coupleur S du régulateur  
de gaz W21.8 Modèle :



Régulateur de gaz  
W21.8, coupleur A

CGA320 Modèle : 2TJZQBFPQGZDSP- D-US	2TJZQBFPQGZDSP-S-E  U	Modèle : 2TJZQBFPQGZDSP- A-EU
--	-----------------------------	-------------------------------------

	<p>Avertissement : Pour réduire le risque de blessure, l'utilisateur doit lire attentivement le manuel d'instructions.</p>
 	<p>Ce produit est soumis aux dispositions de la directive européenne 2012/19/CE. Le symbole représentant une poubelle barrée indique que le produit nécessite une collecte sélective des déchets dans l'Union européenne. Ceci s'applique au produit et à tous les accessoires marqués de ce symbole. Les produits marqués comme tels ne peuvent pas être jetés avec les ordures ménagères normales, mais doivent être déposés dans un point de collecte pour le recyclage des appareils électriques et électroniques.</p>

**Connectez la tour à bière avec les accessoires comme image suivante**





## Comment installer le kit de tour à bière

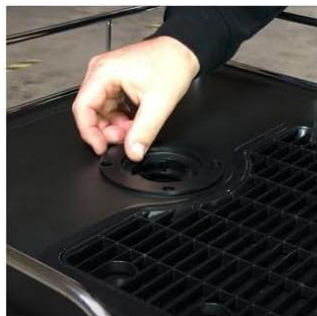

Remove the cover, place the gasket.



Insert tubes through the hole.



Attach the tower with screws.



Install springs and faucet, tighten the collar counterclockwise with a wrench.

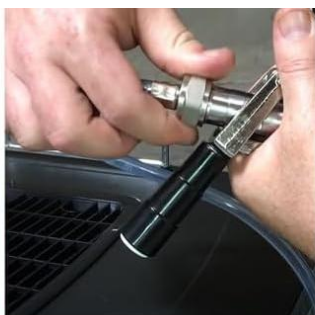

Screw the beer line hexnut onto the coupler.

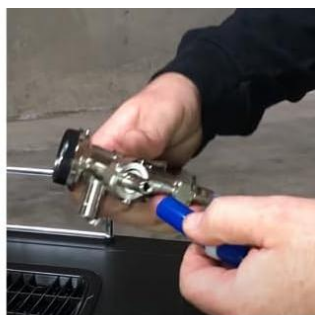

Push air line onto coupler and tighten clamp.







## Notes du régulateur de gaz



All valves of co2 regulator must be closed before using



Connect the keg regulator to the gas tank with a wrench



Open CO2 tank slowly



Set keg pressure by turning pressure adjustment knob towards "+" slowly



Attach hose and turn on the ON/OFF knob to let the gas flow to keg



Pull the pressure relief valve ring to release excess pressure

Les poignées de ce système restent bloquées. Comment régler ceci?

Les robinets qui collent sont un problème courant dans les systèmes de tirage d'air domestiques, surtout lorsqu'ils ne sont pas souvent utilisés. Débrancher le système de tirage et faire couler les robinets sous l'eau

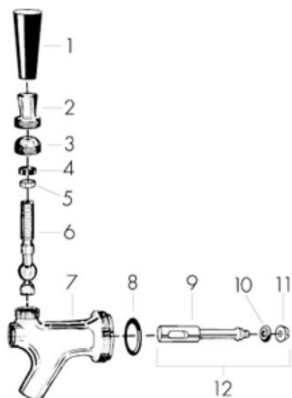

chaude pendant quelques secondes suffit généralement. Pulvériser de l'eau sur l'avant des robinets peut également aider. La bière sèche essentiellement dans la partie avant du robinet, ce qui la fait coller. La bière est très collante une fois sèche, mais l'eau la décompose assez facilement.

Je n'arrive pas à obtenir autre chose que de la mousse, y a-t-il un problème avec mes réglages ?

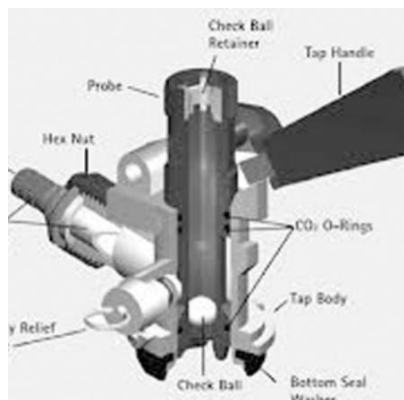

Haute pression de Co2 : nous recommandons normalement 10 à 12 livres. Tirez sur la soupape de décharge du coupleur et ajustez le débit au fur et à mesure que vous versez.

Conduites de bière : Les conduites de bière de plus de 6 pieds peuvent causer des problèmes. Après une longue utilisation, veuillez utiliser notre kit de nettoyage pour vous assurer que les lignes sont exemptes de saleté.  
Rondelle de sonde de coupleur : si elle est endommagée ou manquante, vous obtiendrez toujours de la bière mousseuse.

Mauvaise coulée : Tenez le verre à 45 degrés, inclinez le verre à la verticale lorsque vous atteignez la moitié du chemin.

Tuyau chaud : installez un refroidisseur de tour pour refroidir le tuyau de bière à

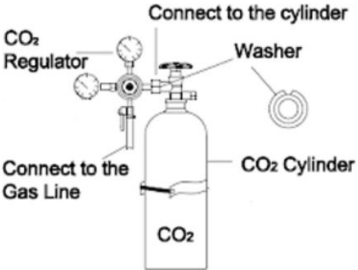
	l'intérieur de la tour.
<p>Comment réparer, trouver et réparer une fuite dans un régulateur ?</p> 	<p>Procurez-vous un flacon pulvérisateur et remplissez-le d'agent moussant. Vous pouvez également utiliser un désinfectant sans rinçage comme Star San mélangé à de l'eau si vous êtes un brasseur amateur. Vous avez juste besoin de quelque chose qui bouillonne lorsque l'air s'échappe.</p> <p>CONSEILS : Une fois l'installation terminée, assurez-vous d'observer l'absence de fuite dans le système afin d'éviter de gaspiller du CO2.</p>

**Fabricant :** Shanghai muxinmuyeyouxiangongsi

**Adresse :** Baoshanqu Shuangchenglu 803long 11hao 1602A-1609shi  
Shanghai

**Importé en Australie :** SIHAO PTY LTD. 1 ROKEVA STREETASTWOOD  
NSW 2122 Australie

**Importé aux États-Unis :** Sanven Technology Ltd. Suite 250, 9166  
Anaheim Place, Rancho Cucamonga, CA 91730



Pooledas Group Ltd  
Unit 5 Albert Edward House,  
The Pavilions Preston, United Kingdom  
pooledas123@gmail.com  
01772418127



SHUNSHUN GmbH  
Römeräcker 9 Z2021,76351  
Linkenheim-Hochstetten, Germany  
euvertreter@gmail.com  
+49 1727041930

**Fabriqué en Chine**



















**BIERTURM**



# BEER TOWER

 <p>Zapfhahn Bierturm Modell: DTPJT</p>	 <p>Zapfhahn Bierturm Modell: DTPJT</p>	 <p>Zapfhahn Bierturm Modell: DTPJT</p>
 <p>CGA320 Gasregler D-Kupplung Modell: 1TJZQBFPQGZ-D-US</p>	 <p>W21.8 Gasregler S-Kupplung Modell: TJZQBFPQGZ-S-EU</p>	 <p>W21.8 Gasregler A-Kupplung Modell: TJZQBFPQGZ-A-EU</p>
		

<p>CGA320 Gasregler D-Kupplung Modell: 2TJZQBFPQGZ-D-US</p>	<p>W21.8 Gasregler S-Kupplung Modell: 2TJZQBFPQGZ-S-EU</p>	<p>W21.8 Gasregler A-Kupplung Modell: 2TJZQBFPQGZ-A-EU</p>
 <p>CGA320 Gasregler D-Kupplung Modell: 1TJZQBFPQGZDSP- D-US</p>	 <p>W21.8 Gasregler S-Kupplung Modell: 1TJZQBFPQGZDSP-S-E U</p>	 <p>W21.8 Gasregler A-Kupplung Modell: 1TJZQBFPQGZDSP- A-EU</p>
 <p>CGA320 Gasregler D-Kupplung Modell: 2TJZQBFPQGZDSP- D-US</p>	 <p>W21.8 Gasregler S-Kupplung Modell: 2TJZQBFPQGZDSP-S-E U</p>	 <p>W21.8 Gasregler A-Kupplung Modell: 2TJZQBFPQGZDSP- A-EU</p>



Warnung: Um das Verletzungsrisiko zu verringern, muss der Benutzer die Bedienungsanleitung sorgfältig lesen.



Dieses Produkt unterliegt den Bestimmungen der europäischen Richtlinie 2012/19/EG. Das Symbol einer durchgestrichenen Mülltonne weist darauf hin, dass das Produkt in der Europäischen Union einer getrennten Müllsammlung bedarf. Dies gilt für das Produkt und alle Zubehörteile, die mit diesem Symbol gekennzeichnet sind. Als solche gekennzeichnete Produkte dürfen nicht über den normalen Hausmüll entsorgt werden, sondern müssen an einer Sammelstelle für das Recycling von Elektro- und Elektronikgeräten abgegeben werden

**Verbinden Sie den Bierturm mit Zubehör wie in der folgenden  
Abbildung dargestellt**





## So installieren Sie das Bierturm-Kit



Remove the cover, place the gasket.



Insert tubes through the hole.



Attach the tower with screws.



Install springs and faucet, tighten the collar counterclockwise with a wrench.

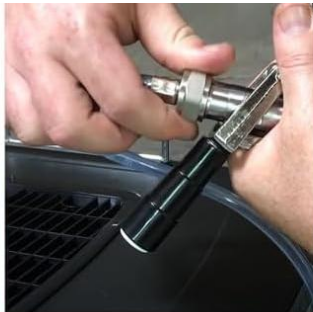

Screw the beer line hexnut onto the coupler.



Push air line onto coupler and tighten clamp.







## Hinweise zum Gasregler



All valves of co2 regulator must be closed before using



Connect the keg regulator to the gas tank with a wrench



Open CO2 tank slowly



Set keg pressure by turning pressure adjustment knob towards "+" slowly



Attach hose and turn on the ON/OFF knob to let the gas flow to keg



Pull the pressure relief valve ring to release excess pressure

Die Griffe dieses Systems bleiben ständig hängen. Wie kann man das beheben?

Festsitzende Wasserhähne sind ein häufiges Problem bei häuslichen Zugluftsystemen, insbesondere wenn sie nicht oft verwendet werden. Normalerweise reicht es aus, das Zapfsystem zu trennen und die

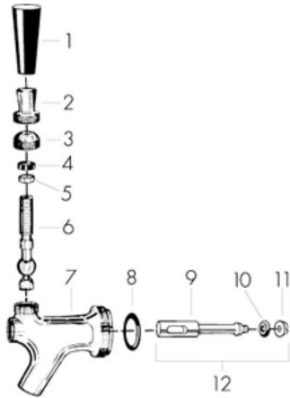

Wasserhähne einige Sekunden lang unter heißes Wasser zu stellen. Auch das Besprühen der Vorderseite der Wasserhähne mit Wasser kann hilfreich sein. Im Wesentlichen trocknet das Bier im vorderen Teil des Wasserhahns, wodurch es klebt. Bier ist im trockenen Zustand sehr klebrig, aber Wasser zersetzt es ziemlich leicht.

Ich bekomme nichts anderes als Schaum. Gibt es ein Problem mit meinen Einstellungen?

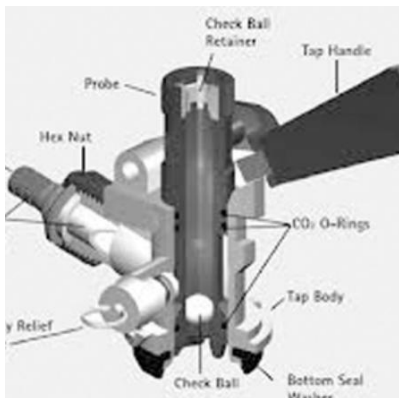

Hoher CO<sub>2</sub>-Druck: Wir empfehlen normalerweise 10–12 Pfund. Ziehen Sie das Überdruckventil an der Kupplung und erhöhen Sie die Förderleistung, während Sie gießen.  
 Bierleitungen: Bierleitungen, die länger als 6 Fuß sind, können Probleme verursachen. Nach längerem Gebrauch nutzen Sie bitte unser Reinigungsset, um sicherzustellen, dass die Leitungen frei von Verschmutzungen sind.  
 Koppler-Sonden-Unterlegscheibe: Wenn sie beschädigt ist oder fehlt, erhalten Sie immer Schaumbier.  
 Schlechter Ausguss: Halten Sie das Glas im 45-Grad-Winkel und kippen Sie es aufrecht, wenn Sie die Hälfte erreicht haben.  
 Warmer Schlauch: Installieren Sie einen Turmkühler, um den Bierschlauch im Inneren des Turms zu kühlen.

Wie kann man ein Leck in einem Regler finden und beheben?

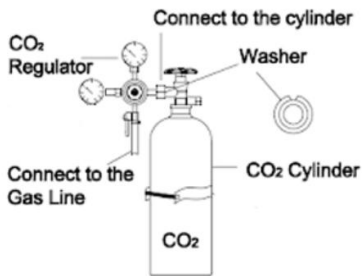

Besorgen Sie sich eine Sprühflasche und füllen Sie sie mit Schaummittel. Sie können auch ein nicht ausspülbares Desinfektionsmittel wie Star San gemischt mit Wasser verwenden, wenn Sie selbst brauen. Sie brauchen nur etwas, das Blasen bildet, wenn Luft entweicht.

TIPPS: Überprüfen Sie das System nach Abschluss der Installation unbedingt auf Undichtigkeiten, um CO2-Verschwendung zu vermeiden.

**Hersteller:** Shanghaimuxinmuyeyouxiangongsi

**Adresse:** Baoshanqu Shuangchenglu 803long 11hao 1602A-1609shi  
Shanghai

**Importiert nach AUS:** SIHAO PTY LTD. 1 ROKEVA STREETEASTWOOD  
NSW 2122 Australien

**In die USA importiert:** Sanven Technology Ltd. Suite 250, 9166 Anaheim  
Place, Rancho Cucamonga, CA 91730



Pooledas Group Ltd  
Unit 5 Albert Edward House,  
The Pavilions Preston, United Kingdom  
pooledas123@gmail.com  
01772418127



SHUNSHUN GmbH  
Römeräcker 9 Z2021,76351  
Linkenheim-Hochstetten, Germany  
euvertreter@gmail.com  
+49 1727041930

**In China hergestellt**











**TORRE DELLA BIRRA**



## BEER TOWER

 <p>toccare la torre della birra Modello: DTPJT</p>	 <p>toccare la torre della birra Modello: DTPJT</p>	 <p>toccare la torre della birra Modello: DTPJT</p>
 <p>Raccordo D del regolatore del gas CGA320 Modello: 1TJZQBFPQGZ-D-US</p>	 <p>Raccordo S regolatore gas W21.8 Modello: TJZQBFPQGZ-S-EU</p>	 <p>Regolatore del gas W21.8 Un accoppiatore Modello: TJZQBFPQGZ-A-EU</p>



Raccordo D del  
regolatore del gas  
CGA320 Modello:  
2TJZQBFPQGZ-D-US



Raccordo S regolatore  
gas W21.8 Modello:  
2TJZQBFPQGZ-S-EU



Regolatore del gas  
W21.8 Un  
accoppiatore Modello:  
2TJZQBFPQGZ-A-EU



Raccordo D del  
regolatore del gas  
CGA320 Modello:  
1TJZQBFPQGZDSP-  
D-US



Raccordo S regolatore  
gas W21.8 Modello:  
1TJZQBFPQGZDSP-S-E  
U



Regolatore del gas  
W21.8 Un  
accoppiatore Modello:  
1TJZQBFPQGZDSP-  
A-EU



Raccordo D del  
regolatore del gas





Raccordo S regolatore  
gas W21.8 Modello:



Regolatore del gas  
W21.8 Un

CGA320 Modello: 2TJZQBFPQGZDSP- D-US	2TJZQBFPQGZDSP-S-E U	accoppiatore Modello: 2TJZQBFPQGZDSP- A-EU
--	-------------------------	--

	<p>Avvertenza: per ridurre il rischio di lesioni, l'utente deve leggere attentamente il manuale di istruzioni.</p>
 	<p>Questo prodotto è soggetto alle disposizioni della Direttiva Europea 2012/19/CE. Il simbolo del bidone della spazzatura barrato indica che nell'Unione Europea il prodotto richiede la raccolta differenziata dei rifiuti. Ciò vale per il prodotto e tutti gli accessori contrassegnati da questo simbolo. I prodotti contrassegnati come tali non possono essere smaltiti con i normali rifiuti domestici, ma devono essere portati in un punto di raccolta per il riciclaggio di dispositivi elettrici ed elettronici</p>

**Collega la torre della birra con gli accessori come  
nell'immagine seguente**





## Come installare il kit della torre della birra



Remove the cover, place the gasket.



Insert tubes through the hole.



Attach the tower with screws.



Install springs and faucet, tighten the collar counterclockwise with a wrench.

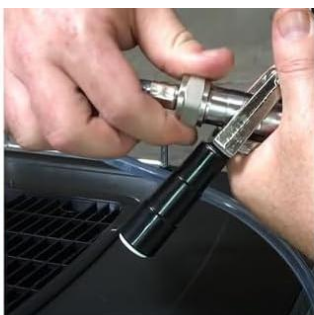

Screw the beer line hexnut onto the coupler.



Push air line onto coupler and tighten clamp.







## Note sul regolatore del gas



All valves of co2 regulator must be closed before using



Connect the keg regulator to the gas tank with a wrench



Open CO2 tank slowly



Set keg pressure by turning pressure adjustment knob towards "+" slowly



Attach hose and turn on the ON/OFF knob to let the gas flow to keg



Pull the pressure relief valve ring to release excess pressure

Le maniglie di questo sistema continuano a rimanere bloccate. Come risolvere questo problema?

I rubinetti incollati sono un problema comune nei sistemi di tiraggio domestici, soprattutto quando non vengono utilizzati spesso. Scollegare il sistema di tiraggio e far scorrere i rubinetti sotto l'acqua calda per alcuni

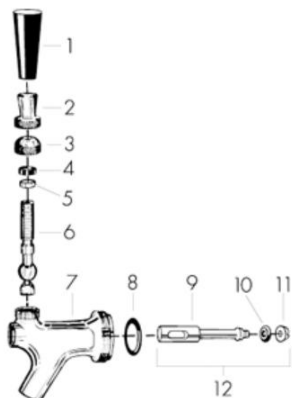

secondi di solito risolve il problema. Anche spruzzare acqua sulla parte anteriore dei rubinetti può aiutare, essenzialmente la birra si asciuga nella parte anteriore del rubinetto facendola aderire, la birra è molto appiccicosa quando è secca ma l'acqua la rompe abbastanza facilmente.

Non riesco a ottenere altro che la schiuma, c'è un problema con le mie impostazioni?

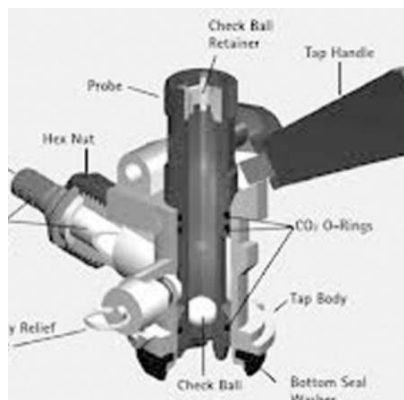

Alta pressione di Co<sub>2</sub>: normalmente consigliamo 10~12 libbre. Tirare la valvola di sicurezza sull'accoppiatore e regolare l'uscita mentre si versa.

Linee della birra: le linee della birra più lunghe di 6 piedi possono causare problemi. Dopo un uso prolungato, utilizzare il nostro kit di pulizia per garantire che le linee siano prive di sporco.

Rondella sonda accoppiatore: se è danneggiata o mancante, otterrai sempre birra schiumata.

Versamento scadente: tenere il bicchiere a 45 gradi, inclinare il bicchiere in posizione verticale quando si raggiunge la metà.

Tubo caldo: installa un dispositivo di raffreddamento della torre per raffreddare il tubo della birra all'interno della torre.

Come risolvere la ricerca e riparare una perdita in un regolatore?

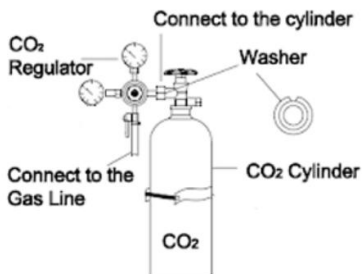

Prendi un flacone spray e riempilo con un agente schiumogeno. Se sei un produttore di birra artigianale, puoi anche utilizzare un disinfettante senza risciacquo come Star San mescolato con acqua. Hai solo bisogno di qualcosa che bolle quando l'aria fuoriesce.

**SUGGERIMENTI:** Al termine dell'installazione, assicurarsi di osservare eventuali perdite del sistema per evitare sprechi di CO2.

**Produttore:** Shanghaimuxinmuyeyouxiangongsi

**Indirizzo:** Baoshanqu Shuangchenglu 803long 11hao 1602A-1609shi  
Shanghai

**Importato in AUS:** SIHAO PTY LTD. 1 ROKEVA STREETEASTWOOD  
NSW 2122 Australia

**Importato negli Stati Uniti:** Sanven Technology Ltd. Suite 250, 9166  
Anaheim Place, Rancho Cucamonga, CA 91730



Pooledas Group Ltd  
Unit 5 Albert Edward House,  
The Pavilions Preston, United Kingdom  
pooledas123@gmail.com  
01772418127



SHUNSHUN GmbH  
Römeräcker 9 Z2021,76351  
Linkenheim-Hochstetten, Germany  
euvertreter@gmail.com  
+49 1727041930

**Made in China**











**TORRE DE CERVEZA**



## BEER TOWER

 <p>torre de cerveza de grifo Modelo: DTPJT</p>	 <p>torre de cerveza de grifo Modelo: DTPJT</p>	 <p>torre de cerveza de grifo Modelo: DTPJT</p>
 <p>Acoplador D del regulador de gas CGA320 Modelo: 1TJZQBFPQGZ-D-US</p>	 <p>Acoplador S del regulador de gas W21.8 Modelo: TJZQBFPQGZ-S-EU</p>	 <p>Regulador de gas W21.8 Un acoplador Modelo: TJZQBFPQGZ-A-EU</p>



Acoplador D del  
regulador de gas  
CGA320 Modelo:  
2TJZQBFPQGZ-D-US



Acoplador S del  
regulador de gas W21.8  
Modelo:  
2TJZQBFPQGZ-S-EU



Regulador de gas  
W21.8 Un acoplador  
Modelo:  
2TJZQBFPQGZ-A-EU



Acoplador D del  
regulador de gas  
CGA320 Modelo:  
1TJZQBFPQGZDSP-  
D-US



Acoplador S del  
regulador de gas W21.8  
Modelo:  
1TJZQBFPQGZDSP-S-E  
U



Regulador de gas  
W21.8 Un acoplador  
Modelo:  
1TJZQBFPQGZDSP-  
A-EU



Acoplador D del  
regulador de gas





Acoplador S del  
regulador de gas W21.8



Regulador de gas  
W21.8 Un acoplador

CGA320 Modelo: 2TJZQBFPQGZDSP- D-US	Modelo: 2TJZQBFPQGZDSP-S-E U	Modelo: 2TJZQBFPQGZDSP- A-EU
---	------------------------------------	------------------------------------

	<p>Advertencia: para reducir el riesgo de lesiones, el usuario debe leer atentamente el manual de instrucciones.</p>
	<p>Este producto está sujeto a las disposiciones de la Directiva Europea 2012/19/CE. El símbolo que muestra un contenedor con ruedas tachado indica que el producto requiere recogida selectiva de basura en la Unión Europea. Esto se aplica al producto y a todos los accesorios marcados con este símbolo. Los productos marcados como tales no podrán desecharse con la basura doméstica normal, sino que deberán llevarse a un punto de recogida para el reciclaje de aparatos eléctricos y electrónicos.</p>

**Conecte la torre de cerveza con los accesorios como se muestra en la siguiente imagen.**





## Cómo instalar el kit de torre de cerveza

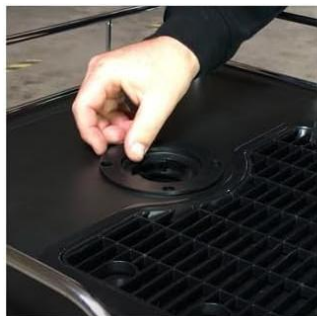

Remove the cover, place the gasket.



Insert tubes through the hole.



Attach the tower with screws.



Install springs and faucet, tighten the collar counterclockwise with a wrench.

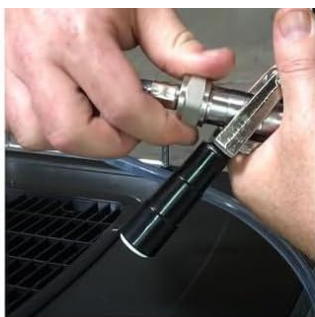

Screw the beer line hexnut onto the coupler.



Push air line onto coupler and tighten clamp.







## Notas del regulador de gas.



All valves of co2 regulator must be closed before using



Connect the keg regulator to the gas tank with a wrench



Open CO2 tank slowly



Set keg pressure by turning pressure adjustment knob towards "+" slowly



Attach hose and turn on the ON/OFF knob to let the gas flow to keg



Pull the pressure relief valve ring to release excess pressure

Las manijas de este sistema siguen atascándose. ¿Cómo arreglar esto?

Los grifos que se atascan son un problema común en los sistemas de tiro domésticos, especialmente cuando no se usan con frecuencia. Desconectar el sistema de tiro y dejar correr los grifos con agua caliente

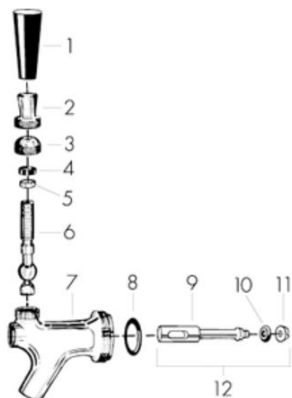

durante unos segundos suele ser suficiente. También puede ayudar rociar el frente de los grifos con agua, esencialmente la cerveza se seca en la parte frontal del grifo y hace que se pegue, la cerveza es muy pegajosa cuando está seca pero el agua la descompone con bastante facilidad.

No puedo conseguir nada más que espuma, ¿hay algún problema con mi configuración?

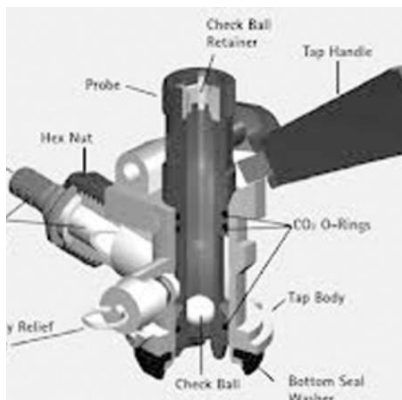

Alta presión de Co2: normalmente recomendamos entre 10 y 12 libras.

Tire de la válvula de alivio en el acoplador y ajuste la salida mientras vierte.

Líneas de cerveza: Las líneas de cerveza de más de 6 pies pueden causar problemas. Después de un uso prolongado, utilice nuestro kit de limpieza para asegurarse de que las líneas estén libres de suciedad.

Arandela de la sonda acopladora: si está dañada o falta, siempre obtendrá cerveza espumosa.

Mal vertido: sostenga el vaso a 45 grados, inclínelo hacia arriba cuando llegue a la mitad.

Manguera caliente: instale un enfriador de torre para enfriar la manguera de cerveza dentro de la torre.

¿Cómo solucionar encontrar

Consigue una botella con atomizador y

y reparar una fuga en un regulador?

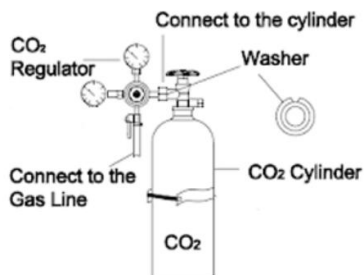

llénala con agente espumante. También puedes usar un desinfectante sin enjuague como Star San mezclado con agua si eres un cervecero casero.

Sólo necesitas algo que burbujee cuando se escape el aire.

CONSEJOS: Una vez completada la instalación, asegúrese de observar el sistema en busca de fugas para evitar el desperdicio de CO2.

**Fabricante:** Shanghaimuxinmuyeyouxiangongsi

**Dirección:** Baoshanqu Shuangchenglu 803long 11hao 1602A-1609shi Shanghai

**Importado a AUS:** SIHAO PTY LTD. 1 ROKEVA STREETASTWOOD NSW 2122 Australia

**Importado a EE. UU.:** Sanven Technology Ltd. Suite 250, 9166 Anaheim Place, Rancho Cucamonga, CA 91730



Pooledas Group Ltd  
Unit 5 Albert Edward House,  
The Pavilions Preston, United Kingdom  
pooledas123@gmail.com  
01772418127



SHUNSHUN GmbH  
Römeräcker 9 Z2021,76351  
Linkenheim-Hochstetten, Germany  
euvertreter@gmail.com  
+49 1727041930

**Hecho en china**





















**WIEŻA PIWNA**



## BEER TOWER

 <p>wieża piwna z kranu Model: DTPJT</p>	 <p>wieża piwna z kranu Model: DTPJT</p>	 <p>wieża piwna z kranu Model: DTPJT</p>
 <p>Złącze D reduktora gazu CGA320 Model: 1TJZQBFPQGZ-D-US</p>	 <p>Złączka S reduktora gazu W21.8 Model: TJZQBFPQGZ-S-EU</p>	 <p>Reduktor gazu W21.8 Złącze Model: TJZQBFPQGZ-A-EU</p>
		

<p>Złącze D reduktora gazu CGA320 Model: 2TJZQBFPQGZ-D-US</p>	<p>Złączka S reduktora gazu W21.8 Model: 2TJZQBFPQGZ-S-EU</p>	<p>Reduktor gazu W21.8 Złącze Model: 2TJZQBFPQGZ-A-EU</p>
		
<p>Złącze D reduktora gazu CGA320 Model: 1TJZQBFPQGZDSP- D-US</p>	<p>Złączka S reduktora gazu W21.8 Model: 1TJZQBFPQGZDSP-S-E U</p>	<p>Reduktor gazu W21.8 Złącze Model: 1TJZQBFPQGZDSP- A-EU</p>
		
<p>Złącze D reduktora gazu CGA320 Model: 2TJZQBFPQGZDSP- D-US</p>	<p>Złączka S reduktora gazu W21.8 Model: 2TJZQBFPQGZDSP-S-E U</p>	<p>Reduktor gazu W21.8 Złącze Model: 2TJZQBFPQGZDSP- A-EU</p>



Ostrzeżenie — aby zmniejszyć ryzyko obrażeń, użytkownik musi uważnie przeczytać instrukcję obsługi.



Ten produkt podlega przepisom Dyrektywy Europejskiej 2012/19/EC. Symbol przekreślonego kosza na śmieci oznacza, że produkt wymaga selektywnej zbiórki śmieci na terenie Unii Europejskiej. Dotyczy to produktu i wszystkich akcesoriów oznaczonych tym symbolem. Produktów oznaczonych jako takie nie można wyrzucać razem ze zwykłymi odpadami domowymi, lecz należy je oddać do punktu zbiórki w celu recyklingu urządzeń elektrycznych i elektronicznych

# Połącz wieżę piwną z akcesoriami jak na poniższym obrazku

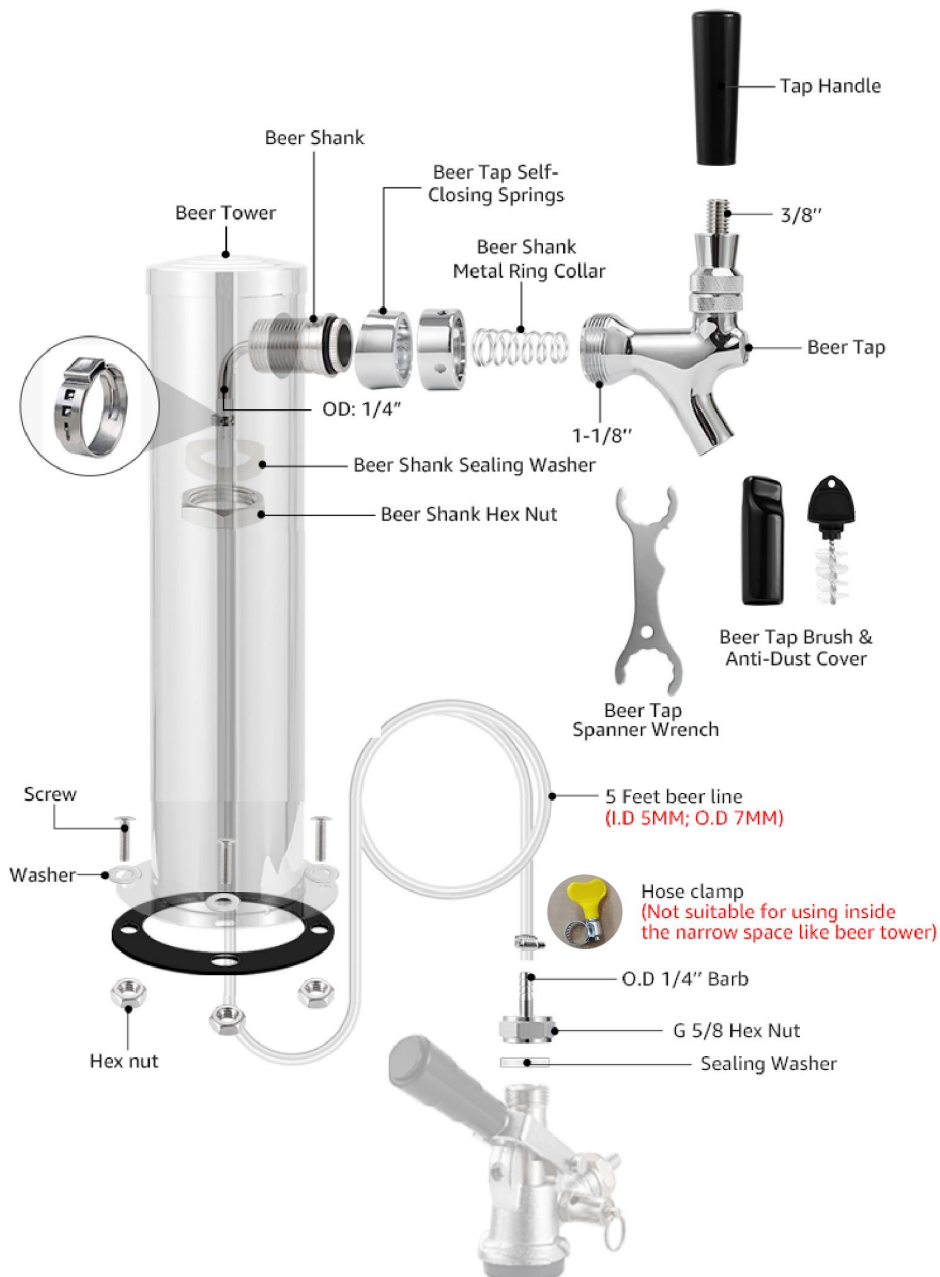



## Jak zainstalować zestaw Beer Tower



Remove the cover, place the gasket.



Insert tubes through the hole.



Attach the tower with screws.



Install springs and faucet, tighten the collar counterclockwise with a wrench.

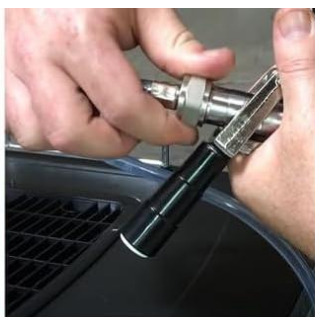

Screw the beer line hexnut onto the coupler.



Push air line onto coupler and tighten clamp.







## Uwagi dotyczące regulatora gazu



All valves of co2 regulator must be closed before using



Connect the keg regulator to the gas tank with a wrench



Open CO2 tank slowly



Set keg pressure by turning pressure adjustment knob towards "+" slowly



Attach hose and turn on the ON/OFF knob to let the gas flow to keg



Pull the pressure relief valve ring to release excess pressure

Uchwyty tego systemu ciągle się zacinają. Jak to naprawić?

Zatykające się kranry są częstym problemem w domowych systemach przeciągów, zwłaszcza gdy nie są one często używane. Odłączenie systemu ciągu i włączenie kranów pod gorącą wodą na kilka sekund zwykle pomaga.

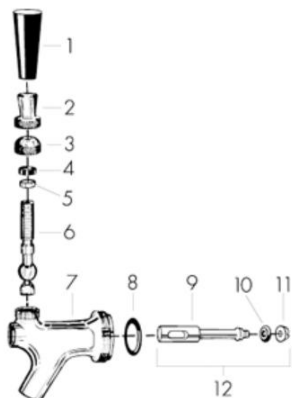

Pomocne może być również spryskanie wodą przedniej części kranu, zasadniczo piwo wysycha w przedniej części kranu, powodując jego przywieranie. Piwo jest bardzo lepkie po wyschnięciu, ale woda dość łatwo je rozkłada.

Nie mogę dostać niczego innego niż piankę. Czy jest jakiś problem z moimi ustawieniami?

Wysokie ciśnienie Co2: Zwykle zalecamy 10 ~ 12 funtów. Pociągnij zawór nadmiarowy na złączce i zwiększ moc wyjściową podczas nalewania.

Linie do piwa: Linie do piwa dłuższe niż 6 stóp mogą powodować problemy. Po długim użytkowaniu należy skorzystać z naszego zestawu do czyszczenia, aby upewnić się, że przewody są wolne od zanieczyszczeń.

Podkładka sondy łącznika: Jeśli jest uszkodzona lub jej brakuje, zawsze otrzymasz piankę piwną.

Słabe nalanie: Trzymaj szklankę pod kątem 45 stopni, przechyl ją do góry, gdy osiągniesz połowę.

Ciepły wąż: Zainstaluj chłodnicę wieżową, aby schłodzić wąż do piwa wewnątrz wieży.

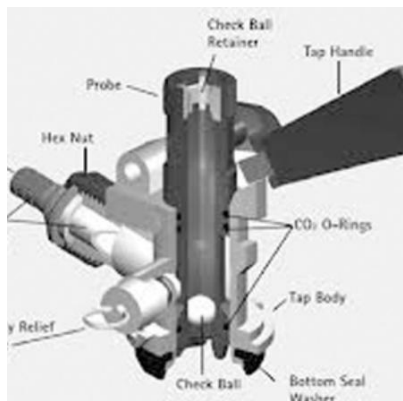

Jak znaleźć i naprawić

Weź butelkę ze sprayem i napełnij ją

nieszczelność w regulatorze?

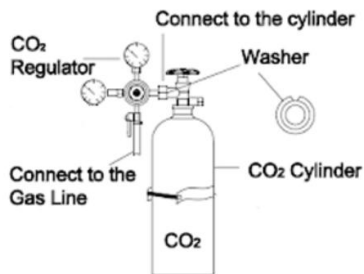

środkiem spieniającym. Jeśli jesteś piwowarem domowym, możesz również użyć środka dezynfekującego bez spłukiwania, takiego jak Star San zmieszanego z wodą. Potrzebujesz po prostu czegoś, co będzie bulgotać, gdy uchroni powietrze.

**WSKAZÓWKI:** Po zakończeniu instalacji należy sprawdzić system pod kątem wycieków, aby uniknąć marnowania CO2.

**Producent:** Shanghai muxin muyeyouxiangongsi

**Adres:** Baoshanqu Shuangchenglu 803long 11hao 1602A-1609shi  
Szanghaj

**Import do AUS:** SIHAO PTY LTD. 1 ROKEVA STREET EASTWOOD NSW  
2122 Australia

**Import do USA:** Sanven Technology Ltd. Suite 250, 9166 Anaheim Place,  
Rancho Cucamonga, CA 91730



Pooledas Group Ltd  
Unit 5 Albert Edward House,  
The Pavilions Preston, United Kingdom  
pooledas123@gmail.com  
01772418127



SHUNSHUN GmbH  
Römeräcker 9 Z2021,76351  
Linkenheim-Hochstetten, Germany  
euvertreter@gmail.com  
+49 1727041930

**Wyprodukowano w Chinach**











**BIER TOREN**



# BEER TOWER

 <p>tapbiertoren Model:DTPJT</p>	 <p>tapbiertoren Model:DTPJT</p>	 <p>tapbiertoren Model:DTPJT</p>
 <p>CGA320 gasregelaar D-koppeling Model: 1TJZQBFPQGZ-D-VS</p>	 <p>W21.8 gasregelaar S-koppeling Model:TJZQBFPQGZ-S- EU</p>	 <p>W21.8 gasregelaar A-koppeling Model:TJZQBFPQGZ- A-EU</p>



CGA320 gasregelaar  
D-koppeling Model:  
2TJZQBFPQGZ-D-US



W21.8 gasregelaar  
S-koppeling Model:  
2TJZQBFPQGZ-S-EU



W21.8 gasregelaar  
A-koppeling Model:  
2TJZQBFPQGZ-A-EU



CGA320 gasregelaar  
D-koppeling Model:  
1TJZQBFPQGZDSP-  
D-US



W21.8 gasregelaar  
S-koppeling Model:  
1TJZQBFPQGZDSP-S-E  
U



W21.8 gasregelaar  
A-koppeling Model:  
1TJZQBFPQGZDSP-  
A-EU



CGA320 gasregelaar  
D-koppeling Model:  
2TJZQBFPQGZDSP-  
D-US



W21.8 gasregelaar  
S-koppeling Model:  
2TJZQBFPQGZDSP-S-E  
U



W21.8 gasregelaar  
A-koppeling Model:  
2TJZQBFPQGZDSP-  
A-EU



Waarschuwing-Om het risico op letsel te verminderen, moet de gebruiker de handleiding zorgvuldig lezen.



Dit product valt onder de bepalingen van de Europese richtlijn 2012/19/EG. Het symbool met een doorgestreepte afvalcontainer geeft aan dat het product in de Europese Unie een aparte afvalinzameling vereist. Dit geldt voor het product en alle accessoires die met dit symbool zijn gemarkeerd. Producten die als zodanig gemarkeerd zijn, mogen niet met het normale huisvuil worden weggegooid, maar moeten naar een inzamelpunt voor recycling van elektrische en elektronische apparaten worden gebracht

**Verbind de biertoren met accessoires zoals volgende afbeelding**





## Hoe u de biertorenkit installeert



Remove the cover, place the gasket.



Insert tubes through the hole.



Attach the tower with screws.



Install springs and faucet, tighten the collar counterclockwise with a wrench.

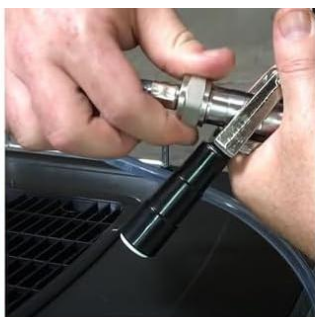

Screw the beer line hexnut onto the coupler.



Push air line onto coupler and tighten clamp.







## Opmerkingen over de gasregelaar



All valves of co2 regulator must be closed before using



Connect the keg regulator to the gas tank with a wrench



Open CO2 tank slowly



Set keg pressure by turning pressure adjustment knob towards "+" slowly



Attach hose and turn on the ON/OFF knob to let the gas flow to keg



Pull the pressure relief valve ring to release excess pressure

De hendels van dit systeem blijven vastlopen. Hoe dit op te lossen?

Vastzittende kranen zijn een veelvoorkomend probleem bij tapsystemen voor thuis, vooral als ze niet vaak worden gebruikt. Meestal volstaat het om het tapsysteem los te koppelen en de kranen een paar

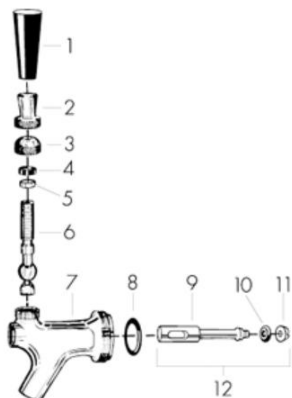

seconden onder heet water te laten lopen. Ook het besproeien van de voorkant van de kranen met water kan ook helpen. In wezen droogt bier in het voorste gedeelte van de kraan, waardoor het blijft plakken. Bier is erg plakkerig als het droog is, maar water breekt het vrij gemakkelijk af.

Ik kan niets anders krijgen dan schuim. Is er een probleem met mijn instellingen?

Hoge Co2-druk: normaal gesproken raden we 10 ~ 12 pond aan. Trek aan de ontlastklep op de koppeling en pas de uitvoer aan terwijl u schenkt.

Bierlijnen: Bierlijnen langer dan 1,80 meter kunnen problemen veroorzaken.

Gebruik na langdurig gebruik onze reinigungsset om ervoor te zorgen dat de leidingen vuilvrij zijn.

Koppelingssondewasmachine: Als deze beschadigd is of ontbreekt, krijgt u altijd schuimbier.

Slecht schenken: Houd het glas 45 graden vast en kantel het glas rechtop als u halverwege bent.

Warme slang: Installeer een torenkoeler om de bierslang in de toren te koelen.

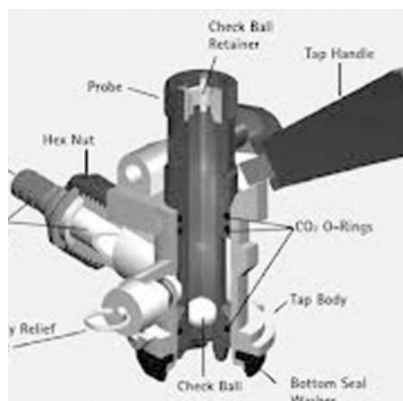

Hoe kan ik een lek in een regelaar opsporen en repareren?

Neem een spuitfles en vul deze met schuimmiddel. Als je een thuisbrouwer bent, kun je ook een

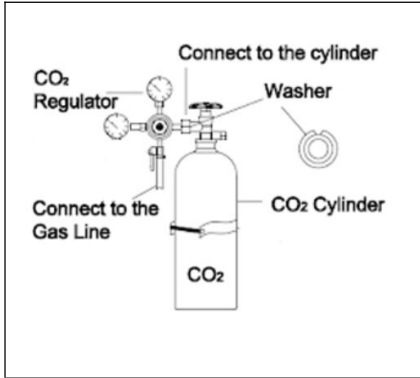

ontsmettingsmiddel gebruiken dat niet hoeft te worden afgespoeld, zoals Star San, gemengd met water. Je hebt gewoon iets nodig dat opborrelt als er lucht ontsnapt.

**TIPS:** Controleer nadat de installatie is voltooid het systeem op lekken om verspilling van CO2 te voorkomen.

**Fabrikant:** Shanghaimuxinmuyeyouxiangongsi

**Adres:** Baoshanqu Shuangchenglu 803long 11hao 1602A-1609shi  
Shanghai

**Geïmporteerd naar AUS:** SIHAO PTY LTD. 1 ROKEVA  
STREETEASTWOOD NSW 2122 Australië

**Geïmporteerd naar de VS:** Sanven Technology Ltd. Suite 250, 9166  
Anaheim Place, Rancho Cucamonga, CA 91730



Pooledas Group Ltd  
Unit 5 Albert Edward House,  
The Pavilions Preston, United Kingdom  
pooledas123@gmail.com  
01772418127



SHUNSHUN GmbH  
Römeräcker 9 Z2021,76351  
Linkenheim-Hochstetten, Germany  
euvertreter@gmail.com  
+49 1727041930

**Gemaakt in China**















**ÖLTORN**



# BEER TOWER

 <p>kranölstorn Modell: DTPJT</p>	 <p>kranölstorn Modell: DTPJT</p>	 <p>kranölstorn Modell: DTPJT</p>
 <p>CGA320 gasregulator D-koppling Modell: 1TJZQBFPQGZ-D-US</p>	 <p>W21.8 gasregulator S-koppling Modell: TJZQBFPQGZ-S-EU</p>	 <p>W21.8 gasregulator A kopplare Modell: TJZQBFPQGZ-A-EU</p>
		

CGA320 gasregulator  
D-koppling Modell:  
2TJZQBFPQGZ-D-US



CGA320 gasregulator  
D-koppling Modell:  
1TJZQBFPQGZDSP-  
D-US

W21.8 gasregulator  
S-koppling Modell:  
2TJZQBFPQGZ-S-EU



W21.8 gasregulator  
S-koppling Modell:  
1TJZQBFPQGZDSP-S-E  
U

W21.8 gasregulator A  
kopplare Modell:  
2TJZQBFPQGZ-A-EU



W21.8 gasregulator A  
kopplare Modell:  
1TJZQBFPQGZDSP-  
A-EU



CGA320 gasregulator  
D-koppling Modell:  
2TJZQBFPQGZDSP-  
D-US



W21.8 gasregulator  
S-koppling Modell:  
2TJZQBFPQGZDSP-S-E  
U



W21.8 gasregulator A  
kopplare Modell:  
2TJZQBFPQGZDSP-  
A-EU



Varning - För att minska risken för skada måste användaren läsa instruktionerna noggrant.



Denna produkt omfattas av bestämmelserna i det europeiska direktivet 2012/19/EC. Symbolen som visar en soptunna korsad anger att produkten kräver separat sophämtning i EU. Detta gäller för produkten och alla tillbehör märkta med denna symbol. Produkter märkta som sådana får inte slängas tillsammans med vanligt hushållsavfall, utan måste lämnas till en insamlingsplats för återvinning av elektriska och elektroniska apparater

# Anslut öltornet med tillbehör enligt följande bild





## Hur man installerar Beer Tower Kit



Remove the cover, place the gasket.



Insert tubes through the hole.



Attach the tower with screws.



Install springs and faucet, tighten the collar counterclockwise with a wrench.

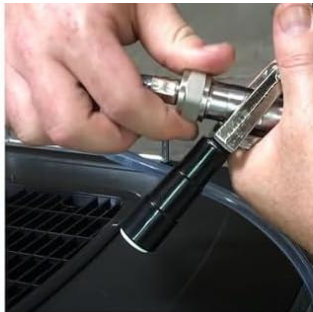

Screw the beer line hexnut onto the coupler.



Push air line onto coupler and tighten clamp.







## Anteckningar om gasregulator



All valves of co2 regulator must be closed before using



Connect the keg regulator to the gas tank with a wrench



Open CO2 tank slowly



Set keg pressure by turning pressure adjustment knob towards "+" slowly



Attach hose and turn on the ON/OFF knob to let the gas flow to keg



Pull the pressure relief valve ring to release excess pressure

Handtagen på detta system fastnar hela tiden. Hur fixar man detta?

Kranar som fastnar är ett vanligt problem i hemdragssystem, särskilt när de inte används ofta. Att koppla bort dragsystemet och köra kranarna under varmt vatten i några sekunder brukar göra susen. Att spraya framsidan av

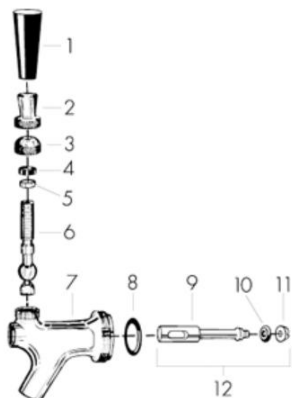

kranarna med vatten kan också hjälpa, i huvudsak torkar öl i den främre delen av kranen vilket gör att det fastnar, öl är väldigt klabbigt när det är torrt men vatten bryter ner det ganska lätt.

Jag kan inte få något annat än skum, är det problem med mina inställningar?

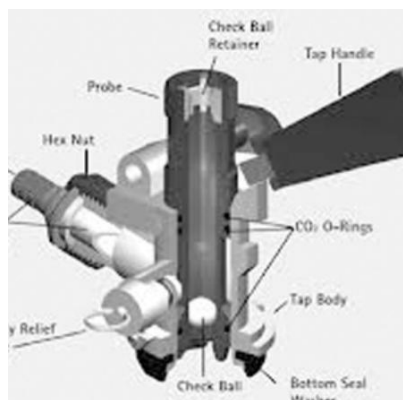

Högt Co2-tryck: Vi rekommenderar normalt 10~12 pund. Dra i avlastningsventilen på kopplingen och justera upp effekten medan du håller.

Öllinjer: Öllinjer längre än 6 fot kan orsaka problem. Efter lång användning, använd vårt rengöringskit för att säkerställa att ledningarna är fria från smuts.

Kopplingsprobbricka: Om den är skadad eller saknas får du alltid skumöl.

Dålig hållning: Håll glaset 45 grader, luta glaset upprätt när du når halvvägs. Varmslang: Installera en tornkylare för att kyla ölslangen inuti tornet.

Hur fixar man hitta och fixa en läcka i en regulator?

Skaffa en sprayflaska och fyll den med skummedel. Du kan också använda ett rengöringsmedel utan sköljning som Star San blandat med vatten om du är en hemmabryggare. Du behöver bara

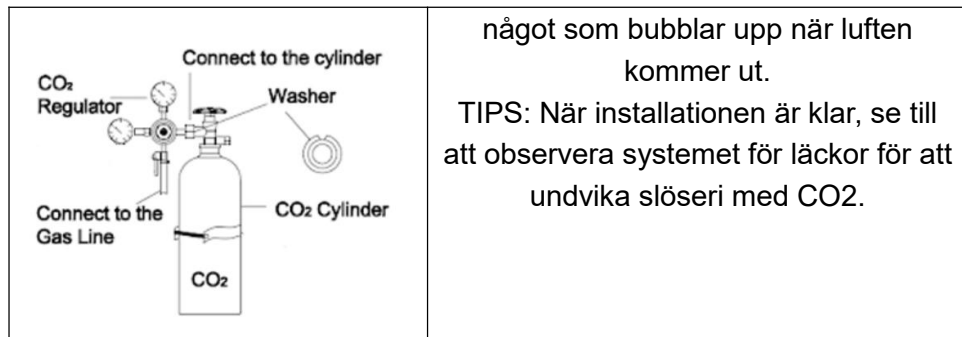

något som bubblar upp när luften kommer ut.  
**TIPS:** När installationen är klar, se till att observera systemet för läckor för att undvika slöseri med CO2.

**Tillverkare:** Shanghaimuxinmuyeyouxiangongsi

**Adress:** Baoshanqu Shuangchenglu 803long 11hao 1602A-1609shi  
 Shanghai

**Importerad till AUS:** SIHAO PTY LTD. 1 ROKEVA STREETEASTWOOD  
 NSW 2122 Australien

**Importerad till USA:** Sanven Technology Ltd. Suite 250, 9166 Anaheim  
 Place, Rancho Cucamonga, CA 91730



Pooledas Group Ltd  
 Unit 5 Albert Edward House,  
 The Pavilions Preston, United Kingdom  
 pooledas123@gmail.com  
 01772418127



SHUNSHUN GmbH  
 Römeräcker 9 Z2021,76351  
 Linkenheim-Hochstetten, Germany  
 euvertreter@gmail.com  
 +49 1727041930

**Tillverkad i Kina**



