

LiFePO4 Battery

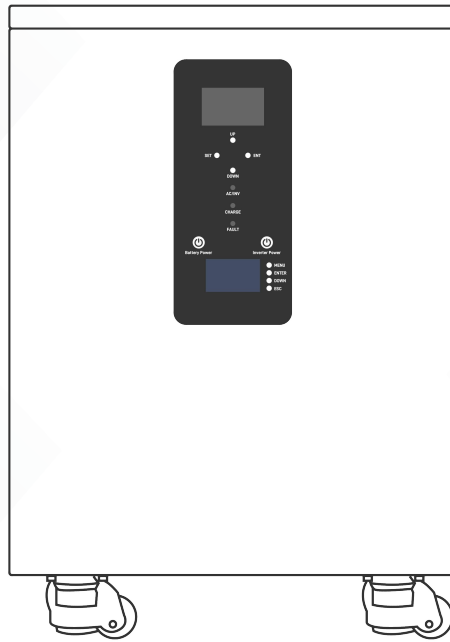

User Manual

Contents

| | |
|--|-----------|
| 1. Instruction | 4 |
| 1.1 How to use this manual | 4 |
| 1.2 Symbols in this manual | 4 |
| 1.3 Safety instructions | 4 |
| 2. Production Instructions | 5 |
| 2.1 Instructions | 5 |
| 2.2 Features | 5 |
| 2.3 System connection diagram | 6 |
| 2.4 Production Overview | 6 |
| 3. Inspections before Installation | 7 |
| 3.1 Inspection of outer package | 7 |
| 3.2 Inspection of deliverable | 7 |
| 4. Installation | 8 |
| 4.1 Select the mount location | 8 |
| 5. Connection | 8 |
| 5.1 Three-phase output | 8 |
| 5.2 Cable & circuit breaker requirement | 10 |
| 5.3 AC input & output connection | 10 |
| 5.4 PV connection | 11 |
| 5.5 Dry contact connection | 11 |
| 5.6 Grounding connection | 12 |
| 5.7 Active Equilibrium Function (Optional) | 12 |
| 5.8 Fire extinguishing function (Optional) | 13 |
| 5.9 Final assembly | 13 |
| 5.10 Start up the inverter | 13 |
| 5.11 Parallel wiring | 13 |
| 6. Operation | 16 |
| 6.1 Operation and display panel | 16 |
| 6.2 AC output mode | 28 |
| 6.3 Battery charging mode | 29 |





| | |
|---|-----------|
| 6.4 Time-slot charging/discharging function | 30 |
| 6.5 Battery parameter | 31 |
| 7. Communication | 33 |
| 7.1 Overview | 33 |
| 7.2 Inverter Communication Interface | 34 |
| 7.3 Battery Communication Interface | 36 |
| 8. Fault and Remedy | 41 |
| 8.1 Fault code | 41 |
| 8.2 Troubleshooting | 42 |
| 9. Protection and Maintenance | 43 |
| 9.1 Protection features | 43 |
| 9.2 Maintenance | 44 |
| 10. Data sheet | 45 |

1. Instruction

1.1 How to use this manual

- This manual contains important information, guidelines, operation and maintenance
- The manual must be followed during installation and maintenance.

1.2 Symbols in this manual

| Symbol | Description |
|---|---|
|  | DANGER indicates a hazardous situations which if not avoided will result in death or serious injury. |
|  | WARNING indicates a hazardous situations which if not avoided could result in death or serious injury. |
|  | CAUTION indicates a hazardous situations which if not avoided could result in minor or moderate injury. |
|  | NOTICE provide some tips on operation of products. |

1.3 Safety instructions

DANGER

- This chapter contains important safety instructions. Read and keep this manual for future reference.
- Be sure to comply the local requirements and regulation to install this inverter.
- Beware of high voltage. Please turn off the switch of each power sources before and during the installation to avoid electric shock.
- For optimum operation of this product, please follow required specification to select appropriate cable size and necessary protective device.
- Do not connect or disconnect any connections when the inverter is working.
- Do not open the terminal cover when the inverter working.
- Make sure the inverter is well grounding.
- Never cause AC output and DC input short circuited.
- Do not disassembly this unit, for all repair and maintenance, please take it to the professional service center.
- Never charge a frozen battery.
- Please keep children away from touching or mishandling the inverter.
- Please make sure that this inverter is the only input power source for the load, do not use it in parallel with other input AC power sources to avoid damage.

2. Production Instructions

2.1 Instructions

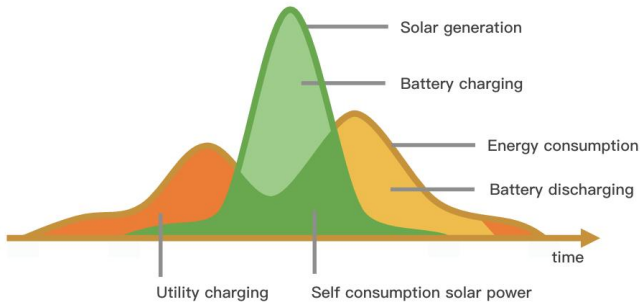

2.2 Features

- Supports lead-acid battery and li-ion battery connections.
- With a dual activation function when the li-ion battery is dormant; either mains or photovoltaic power supply access can trigger the activation of the li-ion battery.
- Support three-phase pure sine wave output (350~415V).
- Supports phase voltage adjustment in the range of 200, 208, 220, 230, 240Vac.
- Supports two PV inputs, with the function of simultaneously tracking the maximum power charging or carrying capacity of two MPPT.
- Dual MPPT, efficiency up to 99.9%, single maximum current of 22A, perfectly adapted to high-power modules.
- 4 charging modes are available: solar only, mains priority, solar priority, and mixed mains and PV charging.
- With time-slot charging and discharging setting function, it helps users to take advantage of peak and valley tariffs and save electricity costs.
- Energy-saving mode function to reduce no-load energy losses.
- With two output modes of utility bypass and inverter output, with uninterrupted power supply function.
- LCD large screen dynamic flow diagram design, easy to understand the system data and operation status.
- 360° protection with complete short-circuit protection, over-current protection, over-voltage protection, under-voltage protection, over-load protection, etc.
- Support CAN, USB, and RS485 communication.

2.3 System connection diagram

The diagram below shows the system application scenario of this product. A complete system consists of the following components:

1. PV modules: converts light energy into DC energy, which can be used to charge the battery via an inverter or directly inverted into AC power to supply the load.
2. Utility grid or generator: connected to the AC input, it can supply the load and charge the battery at the same time. The system can also operate generally without the mains or generator when the battery and the PV module power the load.
3. Battery: The role of the battery is to ensure the regular power supply of the system load when the solar energy is insufficient and there is no mains power.
4. Home load: Various household and office loads can be connected, including refrigerators, lamps, televisions, fans, air conditioners, and other AC loads.
5. Inverter: The energy conversion device of the whole system.

The actual application scenario determines the specific system wiring method.

2.4 Production Overview

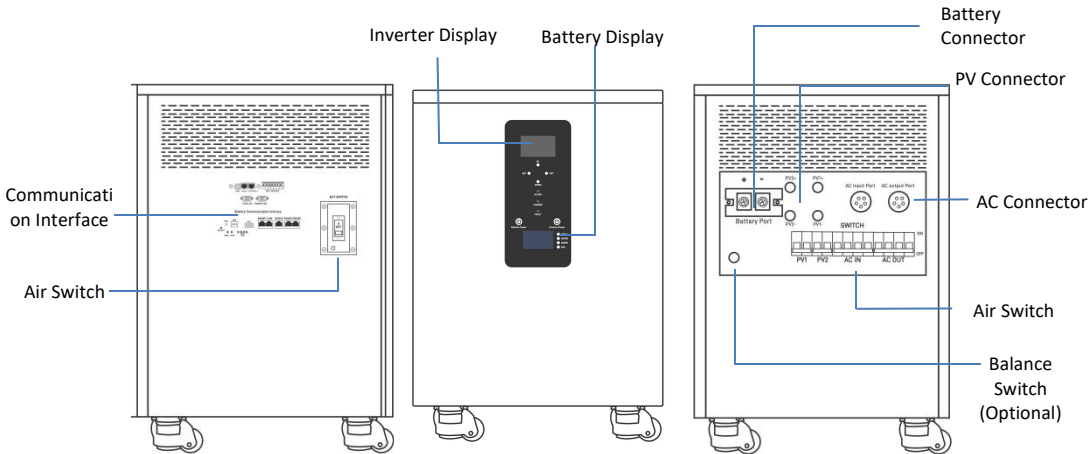





3. Inspections before Installation

3.1 Inspection of outer package

Before opening outer package of the all-in-one machine, check if there is any visible damage on the outer package, such as holes, cracks or other signs of possible internal damage, and check the type of all-in-one machine. If there is any abnormality on the package or model of the all-in-one machine is inconsistent, do not open it and contact us as soon as possible.

3.2 Inspection of deliverable

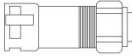
After opening outer package of the all-in-one machine, check if the deliverable is complete and whether there is any visible external damage. If any items are missing or damaged, please contact us.

| No. | Picture | Item | Quantity | Specification |
|-----|---|---|----------|--|
| 1 |  | All-in-one machine | 1 | |
| 2 |  | Parallel communication cable | 1 | |
| 3 |  | Wiring ring | 2 | SC70-10/cold-pressed terminal head thickened wire terminal |
| 4 |  | AC plug | 2 | Connect AC power |
| 5 |  | Photovoltaic connectors | 2 | Solar panel connecting wire terminal |
| 6 |  | Disassembly and assembly tools for solar panel connectors | 1 | |
| 7 | | Product Manual | 1 | |

4. Installation

4.1 Select the mount location

12KW output three-phase integrated machine series are designed for INDOOR USE ONLY (IP20). Please consider the followings before selecting the location.

- Adequate heat dissipation space must be provided for the product.
- The ambient temperature should be between -10~55 °C (14~131 °F) to ensure optimal operation.

⚠ DANGER

- Do not install the inverter where highly flammable materials are near by.
- Do not install the inverter in potential explosive areas.
- Do not install the inverter with lead-acid batteries in a confined space.

⚠ CAUTION

- Do not install the inverter in direct sunlight.
- Do not install or use the inverter in a humid environment.

5. Connection

5.1 Three-phase output

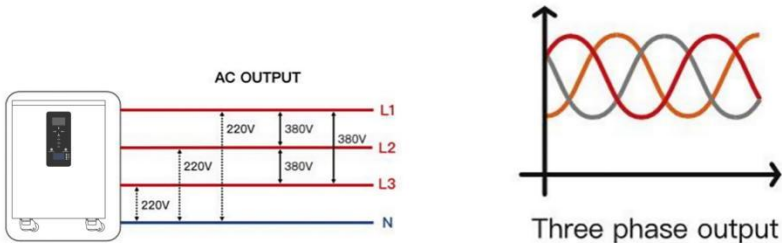

| Items | Description | | | | |
|----------------------------|-------------------------|------------------------|------------------------|------------------------|------------------------|
| Applicable Model | AO-MB51628-380VAC-12KW | AO-MB51600-380VAC-12KW | AO-MB51560-AC380V-12KW | AO-MB51400-380VAC-12KW | AO-MB51300-380VAC-12KW |
| Output Voltage Range (L-N) | 200~240Vac, 230Vac deaf | | | | |

Notice:

Users can change the output phase mode and output voltage by setup menu. Please read the chapter 6.1.2 Setting.

The output voltage corresponds to item [38] of the parameter setting, and the output phase voltage can be set within the range of 200V to 240V.

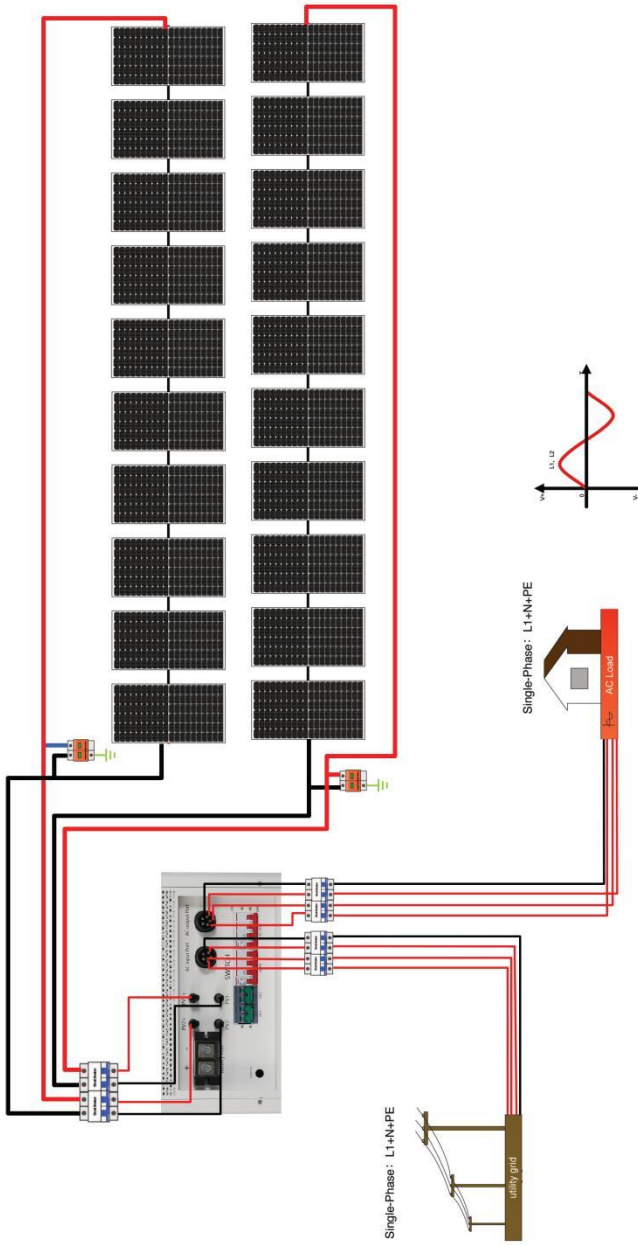

5.2 Cable & circuit breaker requirement

- PV INPUT**

| Models | Cable Diameter | Max. PV Input Current | Circuit Breaker Spec |
|-------------|-------------------------|-----------------------|----------------------|
| SPI-12K-H3P | 5mm ² /10AWG | 22A | 2P-25A |

- AC INPUT**

| Models | Output mode | Max. Input Current | Cable diameter | Circuit Breaker Spec |
|-------------|-------------|--------------------|------------------------------------|----------------------|
| SPI-12K-H3P | Three-phase | 35A | 9mm ² /6AWG(L1/L2/L3/N) | 4P-40A |

- AC OUTPUT**

| Models | Output mode | Max. Input Current | Cable diameter | Circuit Breaker |
|-------------|-------------|--------------------|------------------------------------|-----------------|
| SPI-12K-H3P | Three-phase | 17.4A | 8mm ² /6AWG(L1/L2/L3/N) | 4P-40A |

NOTICE

- AC INPUT、AC OUTPUT**

Connect the marked L1 L2 L3 N PE according to the recommended wire diameter in 5.2, and then plug the 5-hole AC plug into the AC socket on the all-in-one machine

- PV INPUT、PV OUTPUT**

Connect the appropriate wire according to the recommended wire diameter in 5.2

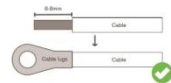
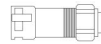

The wire diameter is for reference only. If the distance between the PV array and the inverter or between the inverter and the battery is long, using a thicker wire will reduce the voltage drop and improve the performance of the system.

5.3 AC input & output connection

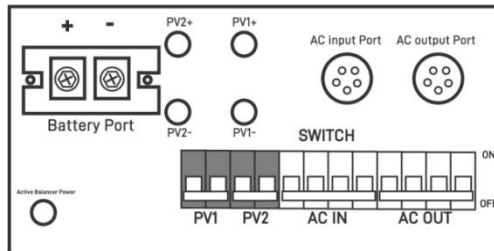

Connect the live, neutral and ground wires according to the cables' position and order shown in the diagram below.

DANGER

- Before connecting AC inputs and outputs, the circuit breaker must be opened to avoid the risk of electric shock and must not be operated with electricity.
- Please check that the cable used is sufficient for the requirements, too thin, poor quality cables are a serious safety hazard.

5.4 PV connection

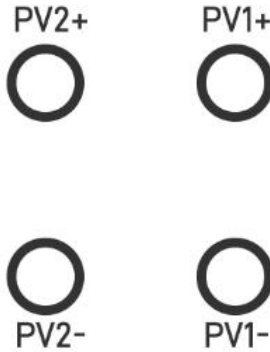

Connect the positive and negative wires of the two strings of PV according to the diagram below.

⚠ DANGER

- Before connecting PV, the circuit breaker must be opened to avoid the risk of electric shock and must not be operated with electricity.

Please make sure that the open circuit voltage of the PV modules in series does not exceed the Max. Open Circuit Voltage of the product (this value is 800V), otherwise the inverter maybe damaged.

5.5 Dry contact connection

Use a small screwdriver to push back the direction indicated by the arrow, then insert the communication cable into the dry junction port. (Communication cable diameter 0.2~1.5mm²)

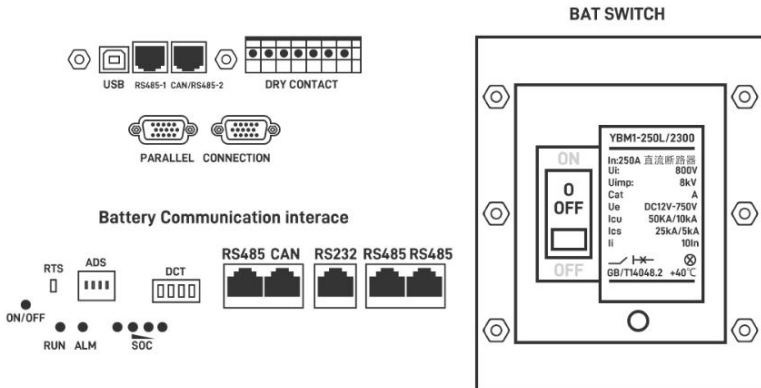

5.6 Grounding connection

Please make sure the grounding terminal connect to the Grounding Bar.

AC input Port AC output Port



NOTICE

- The grounding cable should have a diameter of not less than 4 mm² and be as close as possible to the grounding point.

5.7 Active Equilibrium Function (Optional)

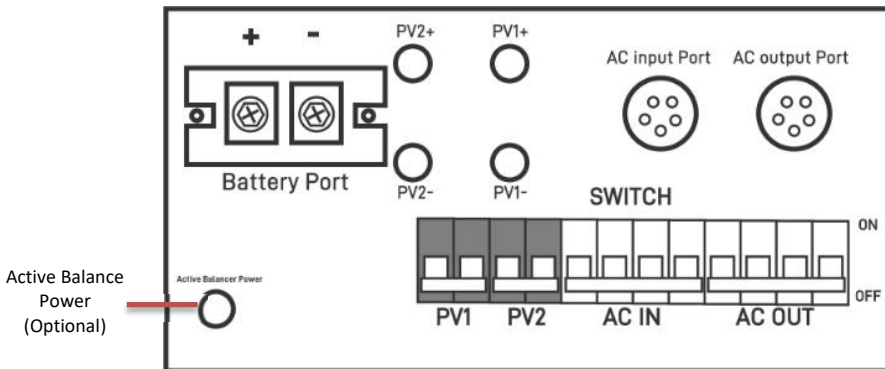

| Test Item | Min | Type | Max |
|---|-------|----------|--------|
| Single IC working voltage (Single series) | 1.8V | | 4.5V |
| Balance opening voltage difference on | | / | |
| Balance closing voltage difference on | | | |
| Accuracy of the balance voltage difference | | 5mV ≅ | |
| Balanced turn-on voltage (first string voltage) | | 2.90V ≅ | |
| Balanced turn off voltage (first string voltage) | | 2.50V ≅ | |
| Balanced current (large voltage difference and large current) | 0 | / | 6A |
| Balanced operating voltage range (B0 to B+ voltage) | 46.4V | | 68.0V |
| current consumption when working | 100uA | | 1000uA |
| current consumption when sleeping | 0 | | 8.0uA |
| Working temperature | | -40~+85℃ | |

5.8 Fire extinguishing function (Optional)

The battery is equipped with an aerosol fire extinguishing device. When the battery experiences a short circuit and catches fire, the fire extinguishing device can detect the temperature and automatically extinguish the fire.

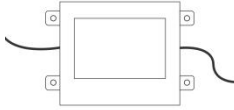

| Item | Parameter |
|---|--------------------------|
| Model specifications | QRR0.04G/S-MC-40-F-02-11 |
| Working temperature range | -30℃~+70℃ |
| Relative humidity of working environment | ≤95%RH |
| Start mode | Hot start |
| Spray time | ≤3s |
| Starting temperature of thermal initiator | 170±10℃ |

5.9 Final assembly

After ensuring that the wiring is reliable and the wire sequence is correct, install the terminal protection cover in place.

5.10 Start up the inverter

- Step 1: Press the switch on the bottom of inverter, close the circuit breaker of the battery.
- Step 2: Press the switch on the bottom of inverter, the screen and indicators light up to indicate that the inverter has been activated.
- Step 3: Sequential close of the circuit breakers for PV, AC input and AC output.
- Step 4: Start the loads one by one in order of power from small to large.

5.11 Parallel wiring

5.11.1 Parallel operation

1. The parallel operation supports up to six solar storage inverters.
2. When using the parallel function, it is necessary to connect the parallel communication cable in a correct and reliable manner. See the figure below for the communication cable (packaging accessory):

Parallel communication cable*1

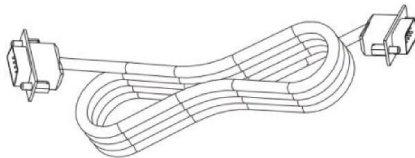

5.11.2 Cautions for parallel connection



Warning:

1. PV wiring:

In parallel connection, the PV array of each inverter must be independent, and the PV array of PV1 and PV2 for one inverter must also be independent.

2. AC OUT wiring:

In single-phase parallel connection, all solar storage inverters must be connected in the manner of L-to-L, N-to-N, and PE-to-PE, and before power on and start-up, it is necessary to check and ensure correct connection, wiring length, and cable size, so as to avoid the abnormal operation of parallel system output caused by wrong connection.

In three-phase parallel connection, all solar storage inverters must be connected in the manner of N-to-N and PE-to-PE. The L lines of all inverters in the same phase shall be connected together, but the AC output L lines of different phases shall not be connected together. Other cautions are the same as those for single-phase parallel connection.

3. AC IN wiring:

In single-phase parallel connection, all solar storage inverters must be connected in the manner of L-to-L, N-to-N, and PE-to-PE, and before power on and start-up, it is necessary to check and ensure correct connection, wiring length, and cable size, so as to avoid the abnormal operation of parallel system output caused by wrong connection. Meanwhile, it is not allowed to have multiple different AC source inputs to avoid damage to the external equipment of the inverter. The AC source input shall be consistent and unique.

In three-phase parallel connection, all solar storage inverters must be connected in the manner of N-to-N and PE-to-PE. The L lines of all inverters in the same phase shall be connected together, but the AC output L lines of different phases shall not be connected together. Other cautions are the same as those for single-phase parallel connection.

4. Communication wiring:

Our company's communication cable for parallel operation is a DB15 standard computer cable with shielding function, and it is used for single-phase or three-phase parallel connection. Each inverter shall be connected with one out and one in, that is, the male connector (out) of the inverter is to be connected to the female connector (in) of the parallel inverter, not the one of the inverter. In addition, DB15 terminal screws will be used to tighten the communication cable of each parallel inverter to avoid falling off or poor contact of the communication cable, followed by abnormal operation or damage of the system output.

5. Before and after connecting the system, please carefully refer to the following system wiring diagrams to ensure that all wiring is correct and reliable before power on.

6. After the system is correctly wired, powered on, and in normal operation, if a new inverter needs to be connected, make sure to disconnect the battery input, PV input, AC input and AC output, and that all solar storage inverters are powered off before reconnecting into the system.

5.1.1.3 Schematic diagram of parallel connection

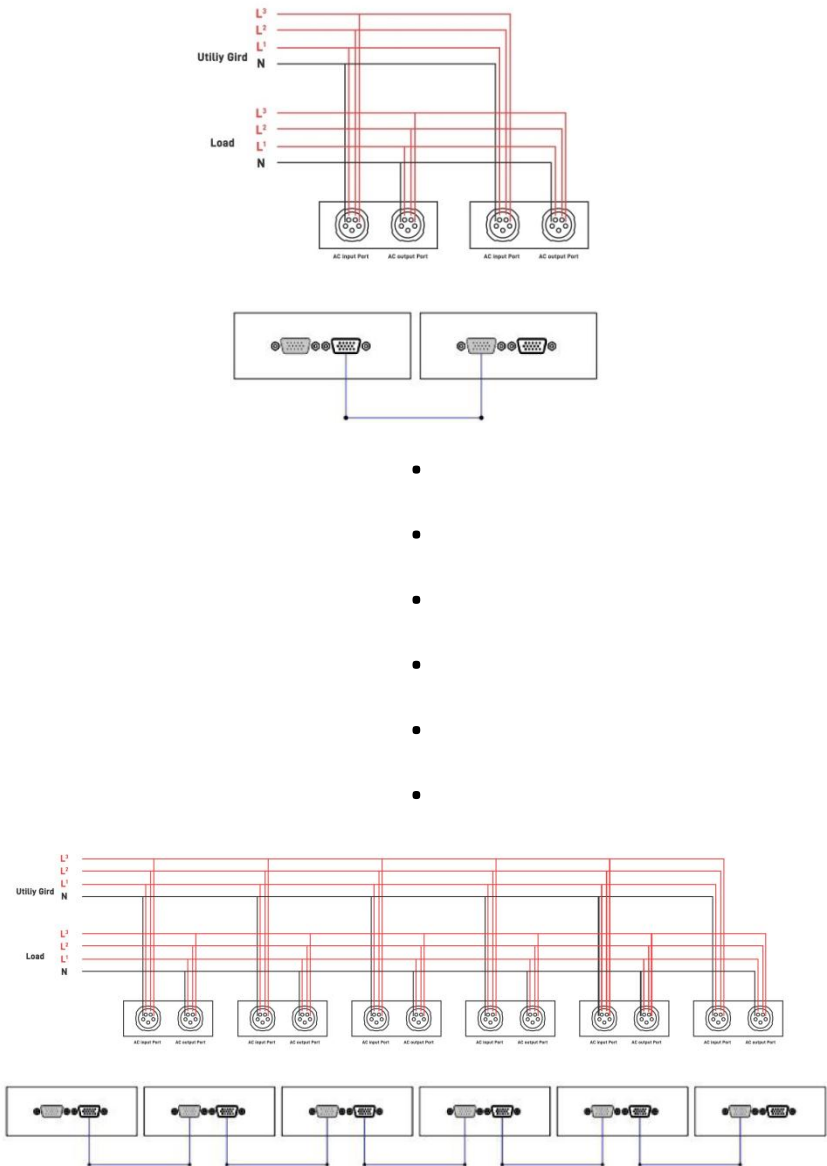

6. Operation

6.1 Operation and display panel

6.1.1 Battery display

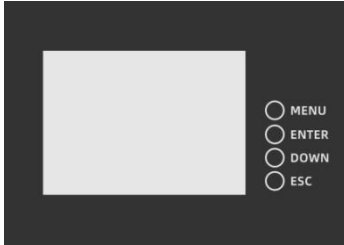

Button Description:

MENU: enter the management system.

ENTER: enter the submenu.

DOWN: moves the cursor down or to the next page.

ESC: returns to the previous one

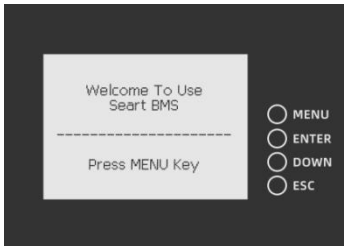

Battery protection status:

Overvoltage: OV

Low voltage: LV

Overtemperature: OTt

Low temperature: IT

Over current: OC

Short circuit: SC

Note: when the battery is protected, the corresponding protection status will be displayed; otherwise, the protection status will not be

Press "MENU" to enter the main menu

Note: "»" indicates that there is a submenu. Press "enter" to enter the submenu

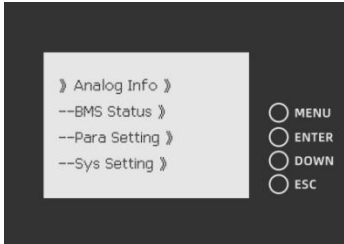

| | |
|--------------|---|
| Analog Info | » |
| BMS Status | » |
| Para Setting | » |
| Sys Setting | » |

Move the cursor to Analog info and press enter

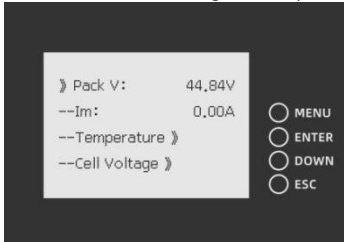

| | |
|--------------|---|
| Pack V | |
| Im | |
| Temperature | » |
| Cell Voltage | » |
| CellCapacity | » |

Move the cursor to "temperature" and press "enter" to check the battery temperature information, then press "down" to turn the page

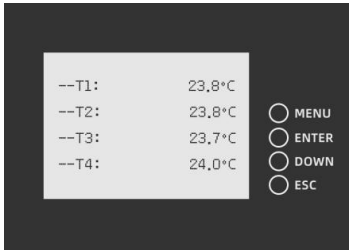

| | |
|-------|------|
| T1 | XX°C |
| T2 | XX°C |
| T3 | XX°C |
| T4 | XX°C |
| PCB-T | XX°C |
| ENV-T | XX°C |

Move the cursor to "cell voltage" and press "enter" to check the battery voltage information, then press "down" to turn the page

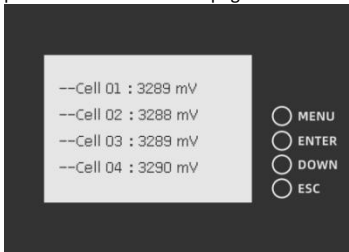

| | |
|---------|--------|
| Cell 01 | xxxxmV |
| Cell 02 | xxxxmV |
| Cell 03 | xxxxmV |
| Cell 04 | xxxxmV |

Move the cursor to "CellCapacity" and press Enter to check the battery capacity information

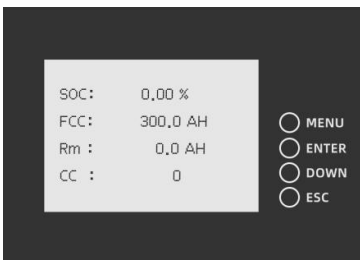

| | |
|-----|-----|
| SOC | X% |
| FCC | XAH |
| Rm | XAH |
| CC | 0 |

Move the cursor to "BMS Status", press Enter to check the battery status, and press "▼" to turn the page

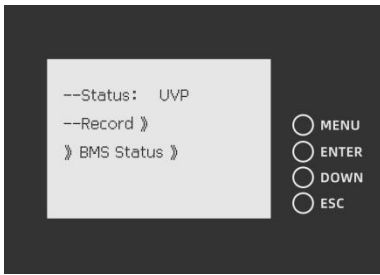

| | |
|------------|----|
| Status | |
| Record | >> |
| BMS Status | >> |

Move the cursor to "Record", then press "Enter" to check the battery alarm information, then press "DOWN" to turn the page.

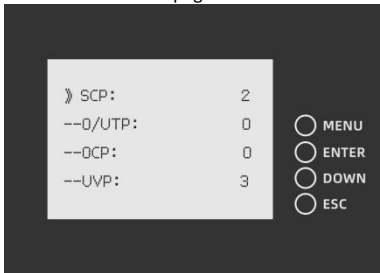

| | |
|-------|--|
| SCP | |
| O/UTP | |
| OCP | |
| UVP | |
| OVP | |

Move the cursor to "BMS Status", then press "Enter" to check the battery protection information, and then press "DOWN" to turn the page.

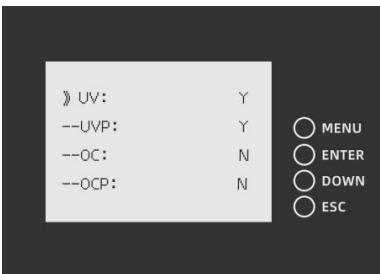

| | |
|---------|-----|
| UV | Y/N |
| UVP | Y/N |
| OC | Y/N |
| OCP | Y/N |
| OT | Y/N |
| OTP | Y/N |
| OV | Y/N |
| OVP | Y/N |
| SCP | Y/N |
| Failure | Y/N |

The user selects the correct communication protocol version by pressing the button and sends the selected protocol version number back to the BMS motherboard program, thereby changing the default communication protocol between BMS and the upper computer. The selection menu for this function is located in the system settings menu directory.

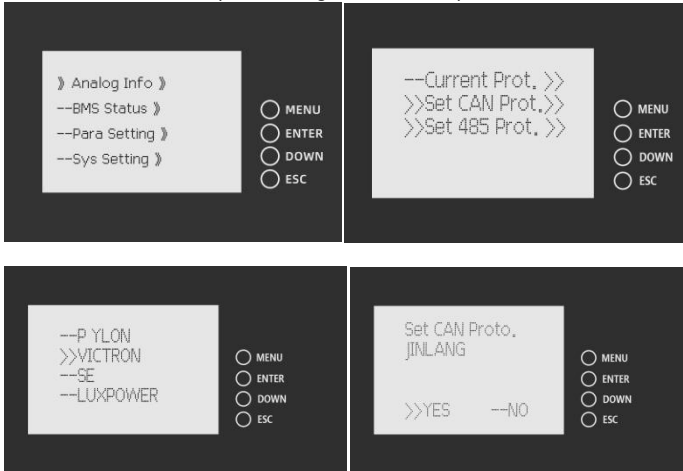

Move the cursor to "Sys Setting", then press Enter to check the version information, and then press "▼" to turn the page.



6.1.2 Inverter display

- The INVERTER DISPLAY

The operation and display panel is as shown below, including 1 LCD screen, 3 indicators and 4 operation buttons.

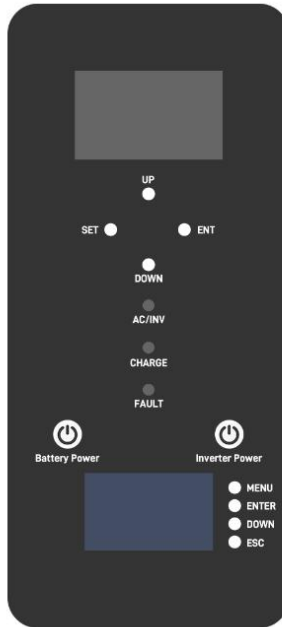

- **Operation buttons introduction**

| Function buttons | Description |
|------------------|--|
| SET | To enter/exit the setting menu |
| UP | To next selection |
| DOWN | To last selection |
| ENT | To confirm/enter the selection in setting menu |







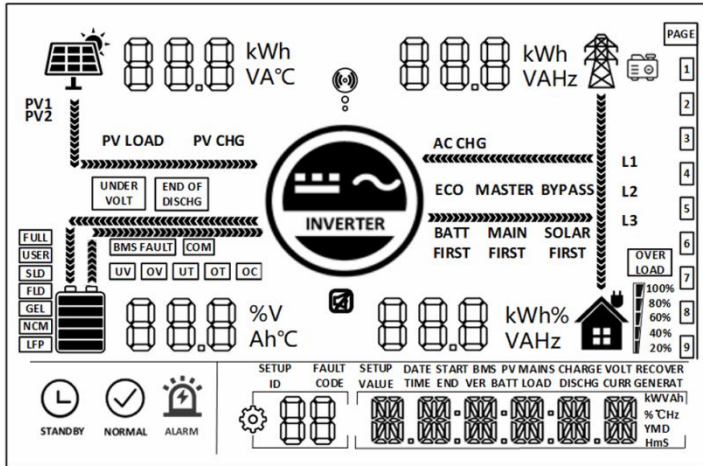















- **LED Indicators**

| Indicators | Colors | Description |
|------------|--------|--|
| AC/INV | Green | Continued: utility grid by-pass output |
| | | Flash: inverter output |
| CHARGE | Yellow | Continued: charging complete |
| | | Flash: charging |
| FAULT | Red | Flash: error occur |

- Display panel



| Icons | Functions | Icons | Functions |
|-------|---|-------|--|
| | Indicates the PV panel | | Indicates the utility grid |
| | Indicates the battery | | Indicates the generator |
| | Indicates the inverter is working | | Indicates the home load |
| | Indicates the inverter is communicating with data collector | | Indicates the buzzer muted |
| | | | Indicates the direction of energy flow |
| | Indicates the inverter is standby | | Indicates the inverter is working normally |
| | Indicates error occur | | Indicates setting |
| | Indicates load power 80%~100% | | Indicates battery SOC 80%~100% |

| | | | |
|--|---|---|---|
|  | Indicates load power 60%~79% |  | Indicates battery SOC 60%~79% |
|  | Indicates load power 40%~59% |  | Indicates battery SOC 40%~59% |
|  | Indicates load power 20%~39% |  | Indicates battery SOC 20%~39% |
|  | Indicates load power 5%~19% |  | Indicates battery SOC 5%~19% |
|  | Indicates battery under-voltage |  | Indicates battery discharge |
|  | Indicates over-load |  | Indicates BMS fault |
|  | Indicates system communication error |  | Indicates system under-voltage |
|  | Indicates system over-voltage |  | Indicates system under-temperature |
|  | Indicates battery is full |  | Indicates system over-current |
|  | Indicates sealed lead-acid battery |  | Indicates user defined battery |
|  | Indicates gel lead-acid battery |  | Indicates flooded lead-acid battery |
|  | Indicates LFP li-ion battery | ECO | Indicates energy-saving mode |
| PV LOAD | Indicates PV energy is carrying the load | PV CHG | Indicates PV energy is charging the battery |
| AC CHG | Indicates ACIN energy is charging the battery | MAIN FIRST | Indicates the inverter output mode is mains power first |
| BYPASS | Indicates the inverter output mode is bypass | SOLAR FIRST | Indicates the inverter output mode is solar first |
| BATT FIRST | Indicates the inverter output mode is battery first | | |

- **View real-time data**

In the main screen, press the UP/DOWN keys to view the real-time data of the inverter during operation.

NOTICE

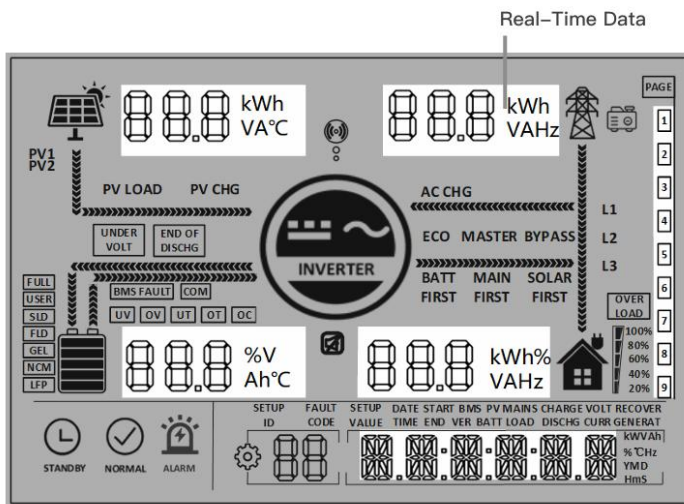

| Page | PV side | BAT side | AC IN side | LOAD side | General |
|------|--------------------------|----------------------------|--------------------------|--------------------------------|------------------|
| 1 | PV voltage | Batt Voltage | AC in voltage | Single phase voltage | Current Time |
| 2 | PV current | Batt Current | AC in current | Single phase Current | Current Date |
| 3 | PV power | Batt Voltage | Total AC charging power | Single phase active power | PV Total kWh |
| 4 | PV today kWh sink | Batt Current | Today AC charging kWh | Single phase apparent power | Load Total kWh |
| 5 | PV side heat temperature | INV Heat Sink Temperature | AC frequency | AC output frequency | RS485 Address |
| 6 | PV rated voltage | Batt Rated Voltage | Busbar voltage | AC output rated power | Software Version |
| 7 | Max. PV charging current | Max. Batt charging current | Max. AC charging Current | Total AC output active power | / |
| 8 | | | / | Total AC output apparent power | / |

● **Setting**

NOTICE

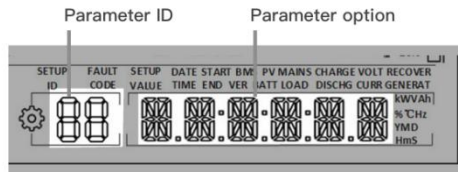
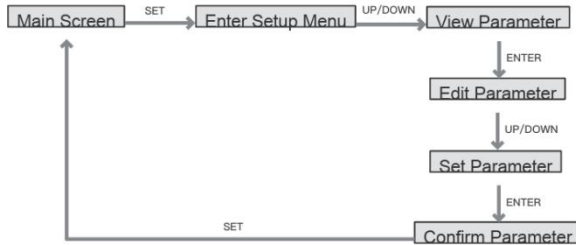

| ID | Parameter Meaning | Options | Description |
|----|--|---------------------|---|
| 00 | Exit | ESC | Exit the setup menu. |
| 01 | AC output source priority | UTI default | Utility Priority. Utility power is given priority to the loads, the battery inverts to provide power to the load only when utility power is unavailable. |
| | | SBU | Prioritises the use of PV to power the load and switches back to the mains to power the load only when the battery voltage is lower than the set value in parameter item [4] (when connected to the BMS, according to item [61]). When the battery voltage is higher than the value set in parameter [5] (when connected to the BMS, according to item [62]), it switches back to the PV from the mains to supply the load. |
| | | SOL | PV priority. Switching to mains to power the load when PV is not effective or when the battery is below the setting of parameter item [4]. |
| 02 | AC output frequency | 50.0 default | In mains mode the AC output frequency will adapt to the mains frequency, otherwise the output will follow the preset values. |
| | | 60.0 | |
| 04 | Voltage point of battery switch to utility | 43.6 default | When parameter [01]= SBU/SOL, output source will switch to utility from battery when the battery voltage below the preset value. Setting range:40~52V. |
| 05 | Voltage point of utility switch to battery | 56.8 default | When parameter [01]=SBU/SOL, output source will switch to battery from utility when the battery voltage above the preset value. Range:48~60V. |
| 06 | Battery charging mode | SNU default | Solar and utility charging the battery at the same time, solar at the first priority, utility power as a supplement when solar power is not sufficient. When solar power is sufficient, the utility stops charging. Note: The PV and mains can only be charged at the |

| | | | |
|----|---|---------------------|--|
| | | | same time when the mains bypass output is loaded. When the inverter is operating, only PV charging can be initiated, not utility charging. |
| | | CUB | Utility is the first priority in charging, PV charging the battery only when utility is not available. |
| | | CSO | PV is the first priority in charging, utility charging the battery only when solar power is not sufficient. |
| | | OSO | PV charging only, no utility charging. |
| 07 | Battery charging current | 120A default | Setting range 0~260A |
| 08 | Battery type | USER | User-defined, user can set all battery parameter |
| | | SLd | Sealed lead-acid battery. |
| | | FLd | Flooded lead-acid battery. |
| | | GEL default | Gel lead-acid battery. |
| | | L14/ L15/ L16 | LFP li-ion battery, 14\15\16 corresponds battery cells number in series. |
| | | N13/ N14 | Ternary li-ion battery. |
| 09 | Battery bulk charging voltage | 57.6 default | Setting range 48V~58.4V, step 0.4V, valid when battery type is custom and lithium battery. |
| 11 | Battery float charging voltage | 55.2 default | Setting range 48V~58.4V, step 0.4V, this parameter can not be set after the BMS communication is successful. |
| 12 | Battery over- discharge voltage (delay off) | 42 default | When the battery voltage is lower than the judgement point, and triggers the parameter [13], the inverter output is switched off, the setting range is 40V~48V, the step is 0.4V, valid when battery type is custom and lithium battery. |
| 13 | Battery over- discharge voltage delay time | 5 default | The battery voltage is lower than parameter [12], and the inverter output is switched off after triggering the delay time set in this parameter, the setting range is 5S~50S, the step is 5S, valid when battery type is custom and lithium battery. |
| 14 | Battery under- voltage alarm | 44 default | When the battery voltage is lower than this judgement point, the device will under-voltage alarm, the output will not be switched off, the setting range is 40V~52V, the step is 0.4V, valid when battery type is custom and lithium battery. |
| 15 | Battery under-voltage limit voltage | 40 default | When the battery voltage is lower than the value of this parameter item, the output will be switched off immediately. Setting range 40V~52V, step 0.4V, valid when battery type is custom and lithium battery. |
| 16 | Battery equalization charging | DIS | Disable equalization charging. |
| | | ENA default | Enable equalization charging, parameter can be set only when battery type is FLd\SLd\USER. |
| 17 | Battery equalization charging voltage | 58 | Setting range: 48V~58V, increment of each click is 0.4V, parameter can be set only when battery type is FLd\SLd\USER. |
| 18 | Battery equalization charging duration | 120 | Setting range: 5min~900min, increment of each click is 5min, parameter can be set only when battery type is FLd\SLd\USER. |
| 19 | Battery equalization charging delay time | 120 | Setting range: 5min~900min, increment of each click is 5min, parameter can be set only when battery type is FLd\SLd\USER. |
| 20 | Battery equalization charging interval | 30 | Setting range: 0~30days, increment of each click is 1day, parameter can be set only when battery type is |

| | | | |
|----|--|--|--|
| | | | FLd\SLd\USER. |
| 21 | Battery equalization charging stop-start | DIS default | Start equalization charging immediately. |
| | | ENA | Stop equalization charging immediately. |
| 22 | Power saving mode | DIS default | Disable power saving mode. |
| | | ENA | Enable energy-saving mode, when the load power is less than 25W, the output of the inverter will switch off after a 5-minute delay. When the load exceeds 25W, the inverter will restart automatically. |
| 23 | Over-load restart | DIS | Disable overload automatic restart, if an overload occurs to shut down the output, the machine will not be restored to power on again. |
| | | ENA default | Enable overload automatic restart. If an overload occurs that shuts down the output, the machine delays for 3 minutes before restarting the output. After accumulating 5 times, it will not restart again. |
| 24 | Over-temperature restart | DIS | Disable over-temperature automatic restart, if over-temperature occurs to switch off the output machine no longer switch on the output. |
| | | ENA default | Enable over-temperature automatic restart, if over-temperature occurs the output is switched off, it will be switched on when the temperature drops. |
| 25 | Buzzer alarm | DIS | Disable buzzer alarm. |
| | | ENA default | Enable buzzer alarm. |
| 26 | Power source switching reminder | DIS | Disable reminder when the status of the input power source changes. |
| | | ENA default | Enable alert when the status of the main input source changes. |
| 27 | Inverter overload switch to bypass | DIS | Disable automatic switching to mains to power the load in the event of an inverter overload. |
| | | ENA default | Automatic switching to mains to power the load in the event of an inverter overload. |
| 28 | Max. utility charging current | 120A | Setting range: 0~120A. |
| 30 | RS485 address | ID:1 | RS485 address setting range: 1~254. |
| 32 | RS485 communication | SLA default | RS485 PC & Remote Monitoring Protocol. |
| | | BMS | RS485 BMS communication function. |
| | | CAN | CAN BMS communication function. |
| 33 | BMS communication | When item [32] = BMS, the corresponding lithium battery manufacturer brand should be selected for communication. | |
| | | WOW default | PAC=PACE, RDA=RITAR, AOG=ALLGRAND, OLT=OLITER, CEF=CFE, XYD=SUNWODA, DAQ=DYNESS, WOW=SRNE, PYL=PYLONTECH, POW=POWMr, UOL=VILION. |
| 34 | Feed back & hybrid output function | DIS default | Disable this function. |
| | | MIX LOD | When parameter [01]=UTI, the solar energy is prioritised to charge the battery and any excess energy will be used to power the load. With an anti-backflow function, the PV energy is not feed back into the grid. |
| | | ON GRD | When parameter [01]=UTI, the solar energy is given priority charging, and when the load demand is met, the remaining power will be fed back to the grid. |
| 35 | Battery under voltage recover point | 52 | When the battery is under-voltage, the battery voltage needs to be higher than this setting value in order to restore the battery inverter AC output, setting range: |

| | | | |
|----|--|--------------------|--|
| | | | 44V~54.4V. |
| 37 | Battery full recharge voltage point | 52 | Inverter stops charging when the battery is full. Inverter resumes charging when the battery voltage below this value. Setting range: 44V~54V. |
| 38 | AC output voltage | 230 | Setting range: 200/208/220/230/240Vac. |
| 39 | Charging current limiting method (when BMS is enabled) | [SET] | The maximum battery charging current is limited according to the setting in [07]. |
| | | [BMS] | Default Maximum battery charging current is limited according to the current limit value of the BMS. |
| | | [INV] | Maximum battery charging current is limited by the machine's derating logic. |
| 40 | 1 st slot start charging | 00:00:00 | Setting range: 00:00:00-23:59:00 |
| 41 | 1 st slot end charging | 00:00:00 | Setting range: 00:00:00-23:59:00 |
| 42 | 2 nd slot start charging | 00:00:00 | Setting range: 00:00:00-23:59:00 |
| 43 | 2 nd slot end charging | 00:00:00 | Setting range: 00:00:00-23:59:00 |
| 44 | 3 rd slot start charging | 00:00:00 | Setting range: 00:00:00-23:59:00 |
| 45 | 3 rd slot end charging | 00:00:00 | Setting range: 00:00:00-23:59:00 |
| 46 | Time slot charging function | DIS default | Disable this function. |
| | | ENA | When the time slot mains charging / carrying loads function is enabled, the power supply mode will change to SBU and switch to mains charging only during the set charging period or when the battery is over-discharged. If the time slot discharging function is enabled at the same time, the system power supply mode will change to UTI, and will only switch to the mains for charging during the set charging period, and switch to the battery inverter power supply during the set discharging period or when the mains is outaged. |
| 47 | 1 st slot start discharging | 00:00:00 | Setting range: 00:00:00-23:59:00 |
| 48 | 1 st slot end discharging | 00:00:00 | Setting range: 00:00:00-23:59:00 |
| 49 | 2 nd slot start discharging | 00:00:00 | Setting range: 00:00:00-23:59:00 |
| 50 | 2 nd slot end discharging | 00:00:00 | Setting range: 00:00:00-23:59:00 |
| 51 | 3 rd slot start discharging | 00:00:00 | Setting range: 00:00:00-23:59:00 |
| 52 | 3 rd slot end discharging | 00:00:00 | Setting range: 00:00:00-23:59:00 |
| 53 | Time slot discharging function | DIS default | Disable this function. |
| | | ENA | When the time slot battery discharging function is enabled, the power supply mode will be switched to UTI, and the system will switch to battery inverter power supply only during the set discharge period or when the mains is outaged. |
| 54 | Local date | 00:00:00 | YY/MM/DD. Setting range: 00:01:01-99:12:31 |
| 55 | Local time | 00:00:00 | Setting range: 00:00:00-23:59:59 |
| 56 | Leakage current detection protection | DIS default | Disable detecting Leakage current value. |
| | | ENA | Enable detecting Leakage current value. |
| 57 | Stop charging current | 2 | Charging stops when the charging current is less than this setting (unit: A). |
| 58 | Discharging alarm SOC | 15 | Triggers an alarm when the battery SOC is less than the set value (unit:%, valid only when BMS communication is normal) |
| 59 | Discharging cutoff SOC | 5 | Stops discharging when the battery SOC is less than the set value (unit:%, valid only when BMS communication is normal) |

| | | | |
|----|---|--------------------------------|--|
| 60 | Charging cutoff SOC | 100 | Stops charging when the battery SOC is higher than the set value (unit:%, valid only when BMS communication is normal) |
| 61 | Switching to utility SOC | 10 | Switch to utility power when the battery SOC is less than this setting value (unit:%, valid only when BMS communication is normal) |
| 62 | Switching to inverter SOC | 100 | Switches to inverter output mode when SOC is higher than this setting value (unit:%, valid only when BMS communication is normal) |
| 63 | N-PE bonding automatic switching function | DIS default | Disable automatic switching of N-PE connections. |
| | | ENA | Enable automatic switching of N-PE connections. |
| 67 | On grid max power | 0 default | you can set the max on-grid power(less than the inverter rated power) |
| 70 | Insulation impedance detection | DIS default | Disable detecting insulation impedance value. |
| | | ENA | Enable detecting insulation impedance value. |
| 71 | PV power priority | First to load | PV energy is prioritized to supply the load; PV power supply logic: Load-Grid-battery charge |
| | | First to charge default | PV energy is prioritized to charge the battery;PV power supply logic: Battery charge-Load-Grid |

6.2 AC output mode

The AC output mode corresponds to parameter setting item 01 and 34, which allows the user to set the AC output power source manually.

- **Utility Priority Output 01 UTI (default)**

Utility at first priority, utility and solar provide power to load at the same time when solar is available, battery will provide power to load only when utility power is not available.(Priority: utility>solar>battery)

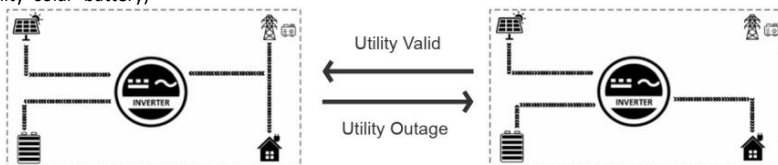

- **Solar and Utility Hybrid Output 34 MIX LOD**

In UTI mode, when not connected to the battery or when the battery is full, the solar and the utility supply power to the load at the same time.(Priority: solar>utility>battery)

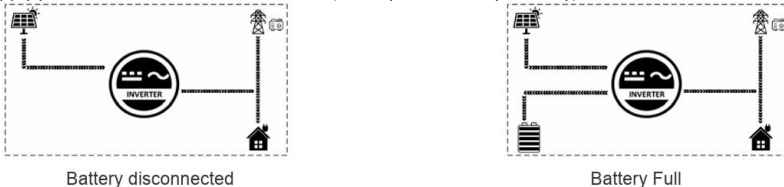

- **Solar Priority Output 01 SOL**

Solar provides power to the loads as first priority. If solar is not available, the utility will be used as a supplement to provide power to the loads. This mode maximize solar energy while maintaining battery power and is suitable for areas with relatively stable power grids.(Priority: solar>utility>battery)

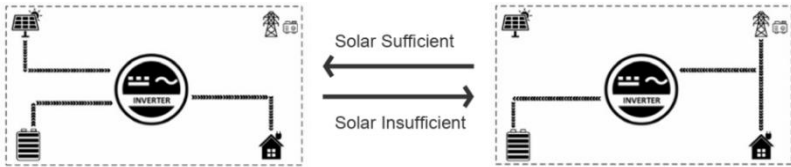

- **Inverter Priority Output 01 SBU**

Solar provides power to the loads as first priority. If solar is not sufficient or not available, the battery will be used as a supplement to provide power to the loads. When the battery voltage reaches the value of parameter 04 (Voltage point of battery switch to utility) will switch to utility to provide power to the load, This model makes maximum use of DC energy and is used in areas where the grid is stable. (Priority: solar>battery>utility)

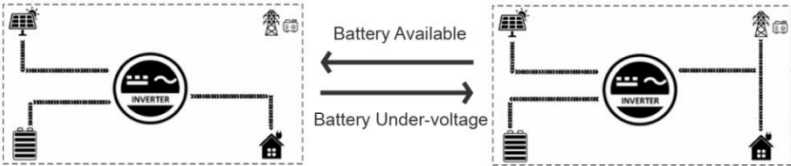

6.3 Battery charging mode

The charging mode corresponds to parameter setting item 06, which allows the user to set the charging mode manually.

- Hybrid Charging SNU(default)

Solar and utility charging the battery at the same time, solar at the first priority, utility power as a supplement when solar power is not sufficient. This is the fastest way to charge and is suitable for areas with low power supply, providing customers with sufficient back-up power.(Source priority: solar>utility)

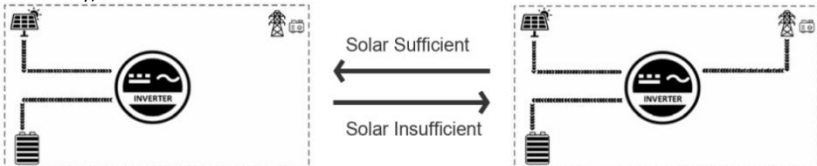

- **Utility Priority Charging CUB**

The utility power gives priority to charging the battery, and PV charging is only activated when the utility power is not available. (Source priority: utility>solar)

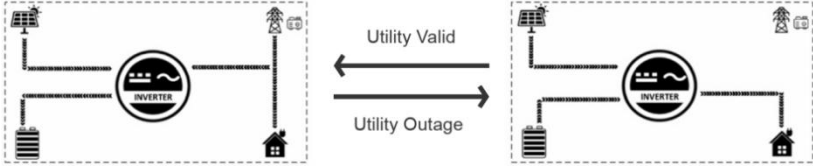

- **Solar Priority Charging CSO**

Solar priority charging, with utility charging only activated when the solar fails. By making full use of solar power during the day and switching to utility charging at night, battery power can be maintained and is suitable for applications in areas where the grid is relatively stable and electricity prices are more expensive. (Source priority: solar>utility)

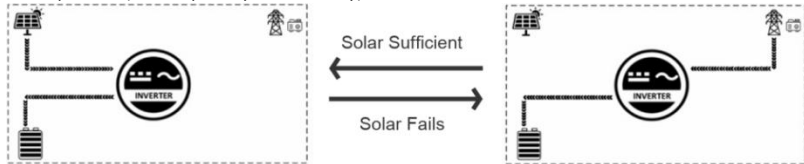

- **Only Solar Charging OSO**

Solar charging only, no mains charging is activated. This is the most energy-efficient method, with all the battery power coming from solar energy, and is usually used in areas with good radiation conditions.



6.4 Time-slot charging/discharging function

12KW output three-phase integrated machine series is equipped with a time-slot charging and discharging function, which allows users to set different charging and discharging periods according to the local peak and valley tariffs, so that the utility power and PV energy can be used rationally.

When mains electricity is expensive, the battery inverter is used to carry the load; when the mains electricity is cheap, the mains electricity is used to carry the load and charge, which can help customers to save electricity costs to the greatest extent.

The user can turn on/off the time-slot charging/discharging function in setup menu parameter 46 and 53, and set charging and discharging slot in parameter 40-45, 47-52. Below are examples for users to understand the function.

NOTICE

Before using this function for the first time, please set the local time in parameter items 54, 55, then the user can set the corresponding time slot according to the local peak and valley tariff charges.

Peak-Valley Electricity Tariff

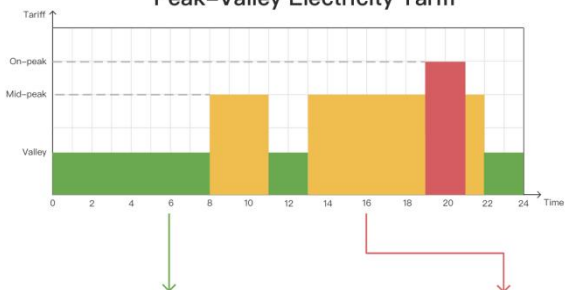

Time-slot Utility Charging/Carrying Function



With 3 definable periods, the user can freely set the mains charging/carrying time within the range of 00:00 to 23:59. During the time period set by the user, if PV energy is available, PV energy will be used first, and if PV energy is not available or insufficient, utility energy will be used as a supplement.

Time-slot Battery Discharging Function



With 3 definable time periods, users can freely set the battery discharge time within the range of 00:00 to 23:59. During the time period set by the user, the inverter will give priority to the battery inverter to carry the load, and if the battery power is insufficient, the inverter will automatically switch to mains power to ensure stable operation of the load.

6.5 Battery parameter

Li-ion battery

| Parameter/Battery type | LFP | | | User-defined |
|-------------------------------|-------|-------|-------|-----------------|
| | L16 | L15 | L14 | |
| Over-voltage cut-off voltage | 60V | 60V | 60V | 60v |
| Equalization charging voltage | - | - | - | 40~60V settable |
| Bulk charging voltage | 56.8V | 53.2V | 49.2V | 40~60V settable |
| Float charging voltage | 56.8V | 53.2V | 49.2V | 40~60V settable |
| Under-voltage alarm voltage | 49.6V | 46.4V | 43.2V | 40~60V settable |
| Under-voltage cut-off voltage | 48.8V | 45.6V | 42V | 40~60V settable |
| Discharging limit voltage | 46.4V | 43.6V | 40.8V | 40~60V settable |

| | | | | |
|--------------------------------|-----------------|-----------------|-----------------|-----------------------|
| Over-discharge delay time | 30s | 30s | 30s | 1~30s settable |
| Equalization charging duration | - | - | - | 0~600min settable |
| Equalization charging interval | - | - | - | 0~250d settable |
| Bulk charging duration | 120min settable | 120min settable | 120min settable | 10~600min settable |

NOTICE

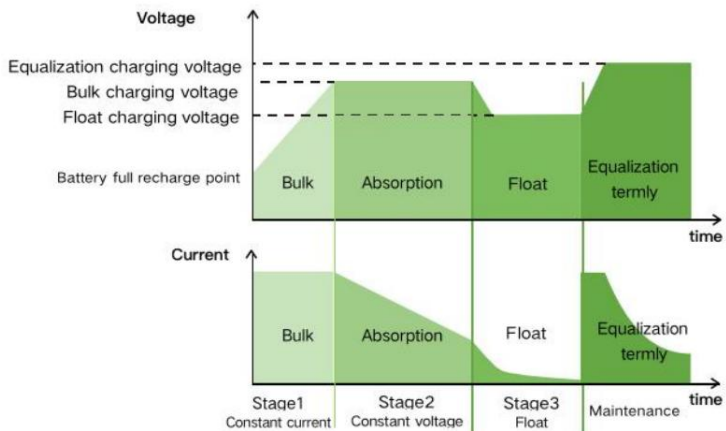

7. Communication

7.1 Overview

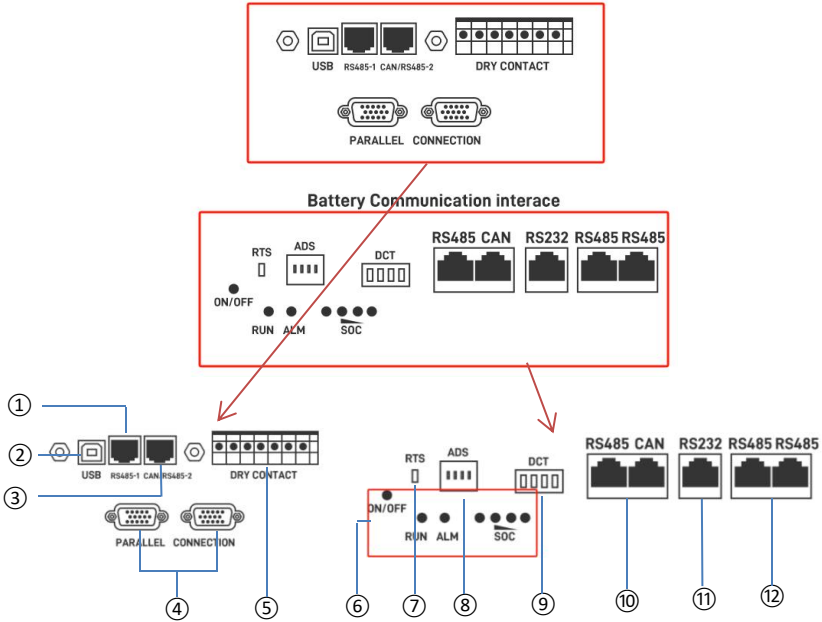

| | | | |
|----------------------------------|--|--------------------------------------|----------------------------------|
| Inverter Communication interface | ① RS485-1 port | ② USB-B port | ③ CAN/RS485-2 port |
| | ④ Parallel connection port | | ⑤ Dry contact port |
| Battery Communication interface | ⑥ LED Indicator | ⑦ RST | ⑧ ADS |
| | ⑨ DCT | ⑩ RS485/CAN (connect to inverter) | ⑪ RS232 (connect to computer) |
| | ⑫ RS485/RS485 (Parallel connection) | | |

7.2 Inverter Communication Interface

7.2.1 RS485-1 Port

The RS485-1 port is used to connect to the Wi-Fi/GPRS data acquisition module, which allows the user to view the operating status and parameters of the inverter via the mobile phone APP.

NOTICE

The Wi-Fi/GPRS data acquisition module need to be purchased separately. User can scan the QR code to download the mobile APP. SU

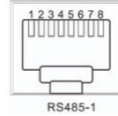

| RJ45 | Definition |
|-------|------------|
| Pin 1 | 5V |
| Pin 2 | GND |
| Pin 3 | / |
| Pin 4 | / |
| Pin 5 | / |
| Pin 6 | / |
| Pin 7 | RS485-A |
| Pin 8 | RS485-B |

7.2.2 USB-B Port

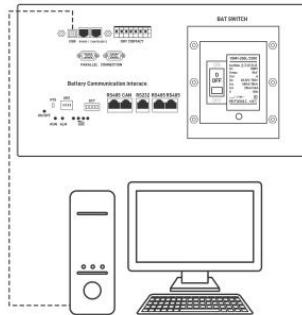

USB typeB Users can use the host computer software to read and modify the device parameters through this port. If you need the installation package of the host computer software, you can download it from the official website of SRNE or contact us to get the installation package.

7.2.3 CAN/RS485-2 Port

The RS485-2 port is used to connect to the BMS of Li ion battery.

NOTICE

If you use a normal RJ45 network cable, please check the pin assignment, pin 1 & pin 2 usually need to be cut off for normal use.

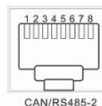

| RJ45 | Definition |
|-------|------------|
| Pin 1 | 5V |
| Pin 2 | GND |
| Pin 3 | / |
| Pin 4 | CANH |
| Pin 5 | CANL |
| Pin 6 | / |
| Pin 7 | RS485-A |
| Pin 8 | RS485-B |

7.2.4 Dry contact

Dry contact port with 4 functions: 1. Remote switch on/off; 2. Switching signal output; 3. Battery temperature sampling; 4. Generator remote start/ stop

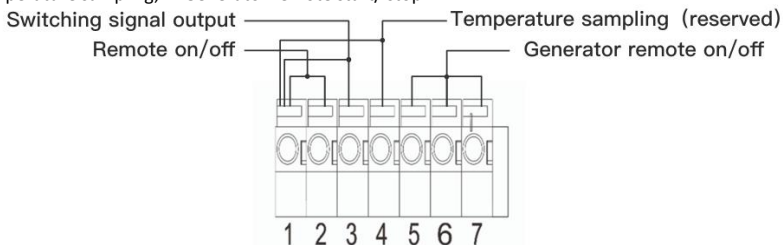

| Function | Description |
|---------------------------------|--|
| Remote switch on/off | When pin 1 is connected with pin 2, the inverter will switched off the AC output. When pin1 is disconnected from pin2, the inverter outputs normally. |
| Switching signal output | When the voltage of battery reaches the <i>under-voltage limit voltage</i> (parameter 15) , pin 3 to pin 1 voltage is 0V, When the battery charging/discharging normally pin 3 to pin 1 voltage is 5V. |
| Temperature sampling (reserved) | Pin 1 & Pin 4 can be used for battery temperature sampling compensation. |
| Generator remote start/stop | When the voltage of battery reaches the <i>under-voltage alarm voltage</i> (parameter 14) or <i>voltage point of utility switch to battery</i> (parameter 04), pin 6 to pin 5 normal open, pin 7 to pin 5 normal close. When the voltage of battery reaches the <i>voltage point of battery switch to utility</i> (parameter 05) or battery is full. pin 6 to pin 5 normal close, pin 7 to pin 5 normal open. (Pin 5/6/7 outputs 125Vac/1A, 230Vac/1A,30Vdc/1A) |

NOTICE

If you need to use the remote start/stop function of the generator with dry contact, ensure that the generator has ATS and supports remote start/stop.

7.3 Battery Communication Interface

7.3.1 LED Indicator

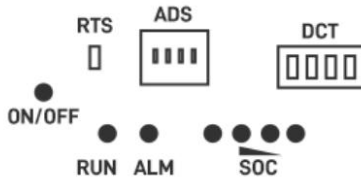

Four green capacity indicators, a red alarm indicator, a green running indicator and a switch indicator.

7.3.2 SOC capacity indicator

| Condition | | Charge | | | | Discharge | | | |
|-------------------------|---------|---------|---------|---------|---------|-----------|-----|-----|-----|
| Capacity indicator lamp | | L1 | L2 | L3 | L4 | L1 | L2 | L3 | L4 |
| power (%) | 0~25% | Flash 2 | OFF | OFF | OFF | ON | OFF | OFF | OFF |
| | 25~50% | ON | Flash 2 | OFF | OFF | ON | ON | OFF | OFF |
| | 50~75% | ON | ON | Flash 2 | OFF | ON | ON | ON | OFF |
| | 75~100~ | ON | ON | ON | Flash 2 | ON | ON | ON | ON |
| Running indicator light | | ON | | | | Flash 3 | | | |

7.3.3 Status indicator

| Status | Warning/Normal /Protection | ON/OFF | Run | Alert | LED Battery Level Indicator | | | | Explain | |
|-----------|----------------------------|--------|---------|---------|---|-----|-----|-----|--|-----------|
| | | ● | ● | ● | ● | ● | ● | ● | | ● |
| Shut down | Sleep mode | ON | OFF | OFF | OFF | OFF | OFF | OFF | OFF | Light off |
| Standby | Normal | ON | Flash 1 | OFF | According to the electricity indication | | | | Standby mode | |
| | Warning | ON | Flash 1 | Flash 3 | | | | | Module low voltage | |
| charge | Normal | ON | ON | OFF | According to the power indicator (the maximum LED of the power indicator flashes 2) | | | | The maximum power LED flashes (flash 2),and the ALM does not flash during the overshoot. | |
| | Warning | ON | ON | Flash 3 | | | | | | |
| | Overcharge Protection | ON | ON | OFF | ON | ON | ON | ON | If there is no mains supply, the indicator turns to standby | |

| | | | | | | | | | |
|-----------|--|-----|---------|---------|-----|-----|-----|-----|-------------------------------|
| | Temperature, over current, failure, protection | ON | OFF | ON | OFF | OFF | OFF | OFF | Stop charging |
| discharge | Normal | ON | Flash 3 | OFF | | | | | |
| | Warning | ON | Flash 3 | Flash 3 | | | | | |
| | UVLO | ON | OFF | OFF | OFF | OFF | OFF | OFF | Stop charging |
| | Temperature, over current, short out, reversed polarity ,FAIL-SAFE | ON | OFF | ON | OFF | OFF | OFF | OFF | Stop discharge |
| Invalid | | OFF | OFF | ON | OFF | OFF | OFF | OFF | Stop charging and discharging |

LED flashing description

| Flashing mode | ON | OFF |
|---------------|-------|-------|
| Flash 1 | 0.25s | 3.75s |
| Flash 2 | 0.5s | 0.5s |
| Flash 3 | 0.5s | 1.5s |

7.3.4 Communication area

Battery Communication interface

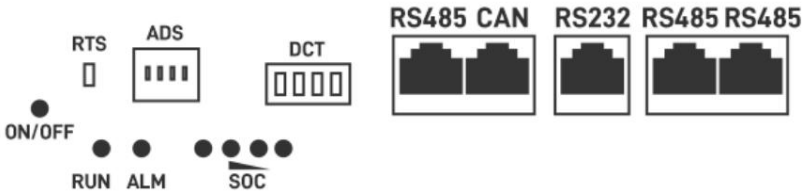

1. RS232: BMS can communicate with upper computer through RS232 interface, so as to monitor various information of battery, including battery voltage, current, temperature, status and battery production information, etc. the default baud rate is 9600bps.
2. RS485: with dual RS485 interface, you can view the information of pack. The default baud rate is 9600bps. If it is necessary to communicate with the monitoring equipment through RS485, the monitoring equipment is used as the host, polling data according to the address, and the address setting range is 1 ~ 15.
3. CAN: CAN communication, baud rate 9600bps.
4. RS485 and CAN: The user can communicate with the inverter through these two interfaces.
5. RS485 add RS232: The users can connect to the computer through these two interfaces.
6. DCT: Dry contact interface.
7. Rst: reset button.
8. ADS: dial switch

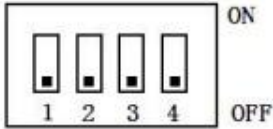

9. Interface diagram

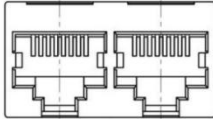

CAN and RS485 interface



Dry contact

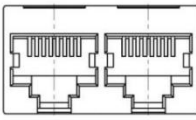

Parallel communication port

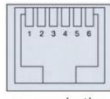

communication interface

10. Definition of electrical interface

| RS232 -- 6P6C vertical RJ11 plug | |
|----------------------------------|------------------------|
| RJ11 pin | Definition Description |
| 2 | NC |
| 3 | TX(Single board) |
| 4 | RX(Single board) |
| 5 | GND |

RS485 and CAN Interface

| RS485 - 8P8C vertical RJ45 socket | | CAN - 8P8C vertical RJ45 socket | |
|-----------------------------------|------------------------|---------------------------------|------------------------|
| RJ45 pin | Definition Description | RJ45 pin | Definition Description |
| 1、8 | RS485-B1 | 9、10、11、14、16 | NC |
| 2、7 | RS485-A1 | 12 | CANL |
| 3、6 | GND | 13 | CANH |
| 4、5 | NC | 15 | GND |

Parallel communication port

| RS485 - 8P8C vertical RJ45 socket | | RS485 - 8P8C vertical RJ45 socket | |
|-----------------------------------|------------------------|-----------------------------------|------------------------|
| RJ45 pin | Definition Description | RJ45 pin | Definition Description |
| 1、8 | RS485-B | 9、16 | RS485-B |

| | | | |
|-----|---------|-------|---------|
| 2、7 | RS485-A | 10、15 | RS485-A |
| 3、6 | GND | 11、14 | GND |
| 4、5 | NC | 12、13 | NC |

11. Bluetooth communication

BMS can communicate with APP through Bluetooth to monitor various information of the battery, including battery voltage, current, temperature, status, SOC, SOH, and battery production information, etc. The default baud rate is 9600bps.

12. WiFi communication

Press and hold the reset button for 10-13 seconds. After all the flow lights are on, it will turn into a state where one light is on. Then release it (except for the ON/OFF light) and wait for 8 seconds to see the new device in the app's device addition section.

7.4.4 WiFi Function Operation Instructions

Android: Scan QR code to download



IOS entrance:

Search for PACE EX download in the App Store

<https://apps.apple.com/cn/app/6461723294>

Local Control (BLE)

When the device is in the standby network state, click the local control button to search for the device on the local control page. If a single or a small number of machines are running, you can directly click on local operation (Bluetooth) to discover and find the corresponding device for local control. Click on the device to enter the device control page.

WiFi remote control



Equipment control and data display



8. Fault and Remedy

8.1 Fault code

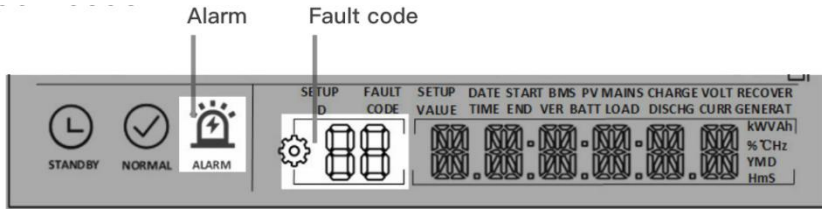

| Fault Code | Meaning | Does it Affect the outputs | Instructions |
|------------|------------------|----------------------------|---|
| 01 | BatVoltLow | Yes | Battery under-voltage alarm |
| 02 | BatOverCurrSw | Yes | Battery discharge over-current, software protection |
| 03 | BatOpen | Yes | Battery disconnected alarm |
| 04 | BatLowEod | Yes | Battery under-voltage stop discharging alarm |
| 05 | BatOverCurrHw | Yes | Battery over-current hardware protection |
| 06 | BatOverVolt | Yes | Battery over-voltage protection |
| 07 | BusOverVoltHw | Yes | Busbar over-voltage hardware protection |
| 08 | BusOverVoltSw | Yes | Busbar over-voltage software protection |
| 09 | PvVoltHigh | Yes | PV input over-voltage protection |
| 10 | PvBoostOCSw | No | Boost circuit over-current software protection |
| 11 | PvBoostOCHw | No | Boost circuit over-current hardware protection |
| 12 | SpiCommErr | Yes | Master-slave chip SPI communication failure |
| 13 | OverloadBypass | Yes | Bypass overload protection |
| 14 | OverloadInverter | Yes | Inverter overload protection |
| 15 | AcOverCurrHw | Yes | Inverter over-current hardware protection |
| 16 | AuxDspReqOffPWM | Yes | Slave chip request switch off failure |
| 17 | InvShort | Yes | Inverter short-circuit protection |
| 18 | Bussoftfailed | Yes | Inverter busbar soft start failed |
| 19 | OverTemperMppt | No | MPPT heat sink over-temperature protection |
| 20 | OverTemperInv | Yes | Inverter heat sink over-temperature protection |

| | | | |
|----|---------------------------------|-----|---|
| 21 | FanFail | Yes | Fan failure |
| 22 | EEPROM | Yes | Reservoir failure |
| 23 | ModelNumErr | Yes | Wrong model |
| 24 | Busdif | Yes | Busbar voltage imbalance |
| 25 | BusShort | Yes | Busbar short circuit |
| 26 | Rlyshort | Yes | Inverter output back flow to bypass |
| 28 | LinePhaseErr | Yes | Utility input phase fault |
| 29 | BusVoltLow | Yes | Busbar under-voltage protection |
| 30 | BatCapacityLow1 | No | Battery SOC below 10% alarm (Only enable BMS take effect) |
| 31 | BatCapacityLow2 | No | Battery SOC below 5% alarm (Only enable BMS take effect) |
| 32 | BatCapacityLowStop | Yes | Battery dead (Only enable BMS take effect) |
| 56 | Low insulation resistance fault | No | PV abnormally low impedance to ground. |
| 57 | Leakage current overload fault | Yes | System leakage current exceeds limit. |
| 58 | BMSComErr | No | BMS communication failure |
| 59 | BMSErr | No | BMS failures occur |
| 60 | BMSUnderTem | No | BMS under-temperature alarm (Only enable BMS take effect) |
| 61 | BMSOverTem | No | BMS over-temperature alarm (Only enable BMS take effect) |
| 62 | BMSOverCur | No | BMS over-current alarm (Only enable BMS take effect) |
| 63 | BMSUnderVolt | No | BMS under-voltage alarm (Only enable BMS take effect) |
| 64 | BMSOverVolt | No | BMS over-voltage alarm(Only enable BMS take effect) |

8.2 Troubleshooting

| Fault Code | Meaning | Causality | Remedy |
|------------|------------------------------------|--|--|
| / | Screen no display | No power input, or in sleep mode. | Closing the circuit breaker. Ensure the rocker switch is ON. Push any button on the panel to exit sleep mode |
| 01 | Battery under-voltage | The battery voltage is lower than the value set in parameter [14]. | Charge the battery and wait until the battery voltage is higher than the value set in the parameter item [14]. |
| 03 | Battery not connected | The battery is not connected, or the BMS in discharge protection | Check whether the battery is reliably connected; check whether the circuit breaker of the battery is not closed; ensure that the BMS of the Li-ion battery can communicate properly. |
| 04 | Battery over-discharge | The battery voltage is lower than the value set in the parameter [12]. | Manual reset: Power off and restart. Automatic reset: charge the battery so that the battery voltage is higher than the value set in the parameter item [35]. |
| 06 | Battery over-voltage when charging | Battery is in over-voltage condition. | Manually power off and restart. Check to see if the battery voltage exceeds |

| | | | |
|----|--|--|--|
| | | | the limit. If it exceeds, the battery needs to be discharged until the voltage is below the battery's over-voltage recovery point. |
| 13 | Bypass over-load (software detection) | Bypass output power or output current overload for a certain period of time. | Reduce the load power and restart the device. Please refer to item 11 of the protection features for more details. |
| 14 | Inverter over-load (software detection) | Inverter output power or output current overload for a certain period of time. | |
| 19 | Heat sink of PV input over-temperature (software detection) | Heat sink of PV input temperature exceeds 90°C for 3s. | Resume normal charge and discharge when the temperature of the heat sink has cooled to below the over-temperature recovery temperature. |
| 20 | Heat sink of inversion over-temperature (software detection) | Heat sink of inversion temperature exceeds 90°C for 3s. | |
| 21 | Fan failure | Fan failure detects by hardware for 3s. | Manually toggle the fan after switching off to check for blockage by foreign objects. |
| 26 | AC Input relay short-circuit | Relay for AC input sticking | Manually power off and restart; if the fault reappears after restarting, You need to contact the after-sales service to repair the machine. |
| 28 | Utility input phase fault | AC input phase does not coincide with AC output phase | Ensure that the phase of the AC input is the same as the phase of the AC output, e.g. if the output is in split-phase mode, the input must also be in split-phase. |

NOTICE

If you encounter a fault with the product that cannot be solved by the methods in the table above, please contact our after-sales service for technical support and do not disassemble the equipment yourself.

9. Protection and Maintenance

9.1 Protection features

| No | Protection Feature | Instruction |
|----|--|--|
| 1 | PV input current/power limiting protection | When the charging current or power of the PV array configured exceeds the PV input rated value, the inverter will limit the input power and charge at the rated. |
| 2 | PV input over-voltage | If the PV voltage exceeds the maximum value allowed by the hardware, the machine will report a fault and stop the PV boost to output a sinusoidal AC wave. |
| 3 | PV night reverse current protection | At night, the battery is prevented from discharging through the PV module because the battery voltage is greater than the voltage of PV module. |
| 4 | AC input over-voltage protection | When the AC input voltage of each phase exceeds 140V, the mains charging will be stopped and switched to the inverter mode. |
| 5 | AC input under-voltage protection | When the AC input voltage of each phase below 90V, the utility charging will be stopped and switched to the inverter mode. |

| | | |
|----|---------------------------------------|--|
| 6 | Battery over-voltage protection | When the battery voltage reaches the over-voltage cut-off point, the PV and the utility will automatically stop charging to prevent the battery from being overcharged and damaged. |
| 7 | Battery under-voltage protection | When the battery voltage reaches the under-voltage cut-off point, the inverter will automatically stop the battery discharge to prevent damage from over-discharging the battery. |
| 8 | Battery over-current protection | After a period when the battery current exceeds that allowed by the hardware, the machine will switch off the output and stop discharging the battery. |
| 9 | AC output short-circuit protection | When a short-circuit fault occurs at the load output terminal, the AC output is immediately turned off and turned on after 1 second. If the output load terminal is still short-circuited after 3 attempts, the inverter must be manually restarted after first removing the short-circuit fault from the load before the normal output can be restored. |
| 10 | Heat sink over-temperature protection | When the internal temperature of the inverter is too high, the inverter will stop charging and discharging; when the temperature returns to normal, the inverter will resume charging and discharging. |
| 11 | Inverter over-load protection | After triggering the overload protection the inverter will resume output after 3 minutes, 5 consecutive overloads will switch off the output until the inverter is restarted. (102%<load< load < 125%) ±10%: error and output shutdown after 10s. Load > 125% ±10%: error reported and output switched off after 5s. |
| 12 | AC output reverse | Prevents AC back flow from the battery inverter to the bypass AC input. |
| 13 | Bypass over-current protection | Built-in AC input over-current protection circuit breaker. |
| 14 | Bypass phase inconsistency protection | When the phase of the bypass input and the phase of the inverter split do not match, the inverter disables switching to the bypass output to prevent the load from dropping out or short-circuiting when switching to the bypass. |

9.2 Maintenance

To maintain optimum and long-lasting working performance, we recommend that the following items are checked twice a year.

1. Ensure that the airflow around the product is not blocked and remove any dirt or debris from the radiator.
2. Check that all exposed conductors are not damaged by sunlight, friction with other surrounding objects, dry rot, insect or rodent damage, etc. The conductors need to be repaired or replaced if necessary.
3. Verify that the indications and displays are consistent with the operation of the equipment, note any faults or incorrect displays and take corrective action if necessary.
4. Check all terminals for signs of corrosion, insulation damage, high temperatures or burning/discolouration and tighten terminal screws.
5. Check for dirt, nesting insects and corrosion, clean anti insects net as required.
6. If the lightning arrester has failed, replace the failed arrester in time to prevent lightning damage to the inverter or other equipment of the user.

DANGER

Make sure that the product is disconnected from all power sources and that the capacitors are fully discharged before carrying out any checks or operations to avoid the risk of electric shock.

The Company shall not be liable for damage caused by:

1. Damage caused by improper use or use in a wrong location.
2. Photovoltaic modules with an open circuit voltage exceeding the maximum permissible voltage.
3. Damage caused by the operating temperature exceeding the restricted operating temperature range
4. Dismantling and repair of the inverter by unauthorised persons.
5. Damage caused by force majeure: damage during transport or handling of the product.

10. Data sheet

| MODEL | AO- MB51600- AC380V- 12KW-EU | AO- MB51628- AC380V- 12KW-EU | AO- MB51560- AC380V- 12KW-EU | AO- MB51400- AC380V- 12KW-EU | AO- MB51300- AC380V- 12KW-EU |
|---|--|---------------------------------------|---------------------------------------|---------------------------------------|---------------------------------------|
| BATTERY TECHNICAL SPECIFICATION | | | | | |
| Battery model | MB51600-300A-HWB | MB51628-300A-HWB | MB51560-300A-HWB | MB51400-300A-HWB | MB51300-300A-HWB |
| Number of batteries | 1 | | | | |
| Battery Energy | 30.72kWh | 32.15kWh | 28.67kWh | 20.48kWh | 15.36kWh |
| Battery Capacity | 600AH | 628AH | 560AH | 400AH | 300AH |
| Weight | 238KG | 238KG | 238KG | 215KG | 173KG |
| Dimension Lx Dx H (mm) | 750*500*845 mm | 750*500*845 mm | 750*500*845 mm | 660*500*850 mm | 660*470*704 mm |
| Battery Type | LiFePO4 | | | | |
| Battery Rated Voltage | 51.2V | | | | |
| Battery Working Voltage Range | 44.8 ~ 57.6V | | | | |
| Maximum Charging Current | 300A | | | | |
| Maximum Discharging Current | 300A | | | | |
| DOD | 80% | | | | |
| Designed Life-span | >6000 Cycles @ 0.2C/25°C Charging/Discharging at 80%DOD, Until 80% Capacity. | | | | |
| INVERTER TECHNICAL SPECIFICATION | | | | | |
| Inverter model | SPI-12K-H3P | | | | |
| PV CHARGE | | | | | |
| Solar Charge | MPPT*2 | | | | |

| | |
|--------------------------------|---|
| Type | |
| Maximum Input Power | 9000W/9000W |
| PV Charging Current Range | 22A+22A |
| PV Operating Voltage Range | 800Vdc/800Vdc |
| MPPT Voltage Range | 200-650Vdc |
| AC CHARGE | |
| Frequency Range | 50/60Hz |
| Input Voltage Range | phase voltage 170~280V, line voltage 305~485V |
| Bypass Overload Current | 35A |
| AC OUTPUT | |
| Rated Output Power | 12000W |
| Max. Peak Power | 24000W |
| Rated Output Voltage | 230/400Vac (three-phase) |
| Load Capacity of Motors | 6HP |
| Rated AC Frequency | 50/60Hz |
| Waveform | Pure Sine Wave |
| Switch Time | 10ms (typical) |
| BATTERY INVERTER OUTPUT | |
| Rated Output Power | 12000W |
| Maximum Peak Power | 24000W |
| Power Factor | 1 |
| Rated Output Voltage | 230/400Vac (three-phase) |

| | |
|-----------------------------|---------------------------------|
| (Vac) | |
| Frequency | 50Hz ± 0.3Hz/60Hz ± 0.3Hz |
| Auto Switch Period | <15ms |
| THD | <3% |
| GENERAL DATA | |
| Protection Degree | IP20, Indoor Only |
| Operating Temperature Range | -15~55℃, >45℃ derated |
| Noise | <60dB |
| Cooling Method | Internal Fan |
| COMMUNICATION | |
| Embedded Interfaces | Rs485 / CAN / USB / Dry contact |
| External Modules (Optional) | Wi-Fi / GPRS |

Join Us for More Discount