

Montageanleitung | Instructions de montage Assembly Instructions | Instrucciones de montaje

N616P308949/N616P308950/N616P308951

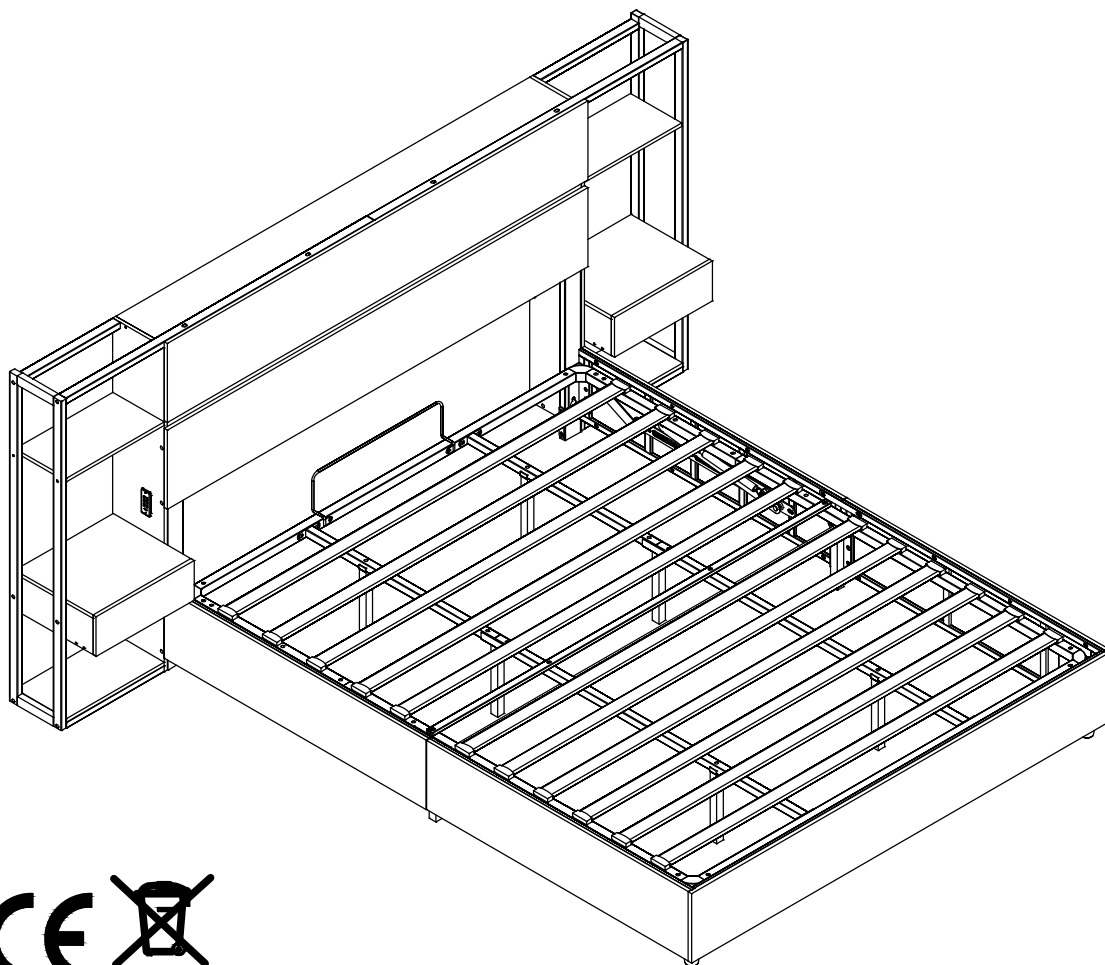

GB This set comes in 3 boxes. If you do not receive a full set of 3 boxes, please contact our customer service.

DE Dieses Set wird in 3 Schachteln geliefert. Wenn Sie nicht ein komplettes Set von 3 Boxen erhalten, kontaktieren Sie bitte unseren Kundenservice.

FR Ce set est livré en 3 boîtes. Si vous ne recevez pas un jeu complet de 3 boîtes, veuillez contacter notre service clientèle.

English

IMPORTANT FOR GAS LIFT BEDS&MAINTAINANCE

- Please place the mattress on top of the bed frame.
- Please do not pull on the strap handles.
- Please press heavily to release the compressed gas.
- Periodically check all screw & fixings to ensure they are secure.
- When moving your product, carefully lift into place.
- Wipe clean with a slightly damp cloth- please do not use abrasive chemicals or bleach.
- Do NOT allow children to operate the lift mechanism.
- Do NOT allow children near the lift base when operating the mechanism.
- Do NOT stand inside the bed or the internal storage base.
- Do NOT overload the internal storage base.
- DO NOT jump on the product or any of its parts.

Deutsch

WICHTIG FÜR GASLIFT-BETTEN&WARTUNG

- Bitte legen Sie die Matratze oben auf den Bettrahmen.
- Bitte ziehen Sie nicht an den Gurtgriffen.
- Bitte drücken Sie kräftig, um das komprimierte Gas freizusetzen.
- Überprüfen Sie regelmäßig alle Schrauben und Befestigungen, um sicherzustellen, dass sie sicher sind.
- Wenn Sie Ihr Produkt bewegen, heben Sie es vorsichtig an seinen Platz.
- Mit einem leicht feuchten Tuch abwischen - bitte keine scheuernden Chemikalien oder Bleichmittel verwenden.
- Erlauben Sie Kindern NICHT, den Hebemechanismus zu bedienen.
- Lassen Sie Kinder NICHT in die Nähe des Liftsockels, wenn Sie den Mechanismus bedienen.
- Stellen Sie sich NICHT in das Bett oder in die Innenablage.
- Überlasten Sie den internen Liftsockel NICHT.
- Springen Sie NICHT auf das Produkt oder eines seiner Teile.

Français

IMPORTANT POUR LES LITS À RELEVAGE DE GAZ&MAINTENANCE

- Veuillez placer le matelas sur le dessus du cadre de lit.
- Ne tirez pas sur les poignées de la sangle.
- Appuyez fortement pour libérer le gaz comprimé.
- Vérifiez régulièrement que toutes les vis et fixations sont bien en place.
- Lorsque vous déplacez votre produit, soulevez-le avec précaution pour le mettre en place.
- Nettoyez avec un chiffon légèrement humide - n'utilisez pas de produits chimiques abrasifs ou d'eau de Javel.
- Ne laissez pas les enfants utiliser le mécanisme de levage.
- Ne laissez pas les enfants s'approcher de la base de levage lorsqu'ils actionnent le mécanisme.
- Ne vous tenez PAS à l'intérieur du lit ou de la base de stockage interne.
- Ne surchargez pas la base de stockage interne.
- Ne pas sauter sur le produit ou l'une de ses parties.

Italiano

IMPORTANTE PER I LETTI CON SOLLEVAMENTO A GAS E LA MANUTENZIONE

- Posizionare il materasso sopra la struttura del letto.
- Non tirare le maniglie della cinghia.
- Premere con forza per rilasciare il gas compresso.
- Controllare periodicamente tutte le viti e i fissaggi per assicurarsi che siano saldi.
- Quando si sposta il prodotto, sollevarlo con cautela.
- Pulire con un panno leggermente umido, senza usare prodotti chimici abrasivi o candeggina.
- NON permettere ai bambini di azionare il meccanismo di sollevamento.
- NON permettere ai bambini di avvicinarsi alla base di sollevamento quando si aziona il meccanismo.
- NON sostare all'interno del letto o della base di contenimento interna.
- NON sovraccaricare la base di contenimento interna.
- NON saltare sul prodotto o sulle sue parti.

Español

IMPORTANTE PARA LAS CAMAS ELEVADORAS DE GAS&MANTENIMIENTO

- Coloque el colchón sobre el somier.
- No tire de las asas de la correa.
- Presione con fuerza para liberar el gas comprimido.
- Compruebe periódicamente que todos los tornillos y fijaciones estén bien sujetos.
- Al mover el producto, levántelo con cuidado para colocarlo en su sitio.
- Limpie con un paño ligeramente humedecido; no utilice productos químicos abrasivos ni lejía.
- NO permita que los niños accionen el mecanismo de elevación.
- NO permita que los niños se acerquen a la base elevadora cuando accionen el mecanismo.
- NO se ponga de pie dentro de la cama o de la base de almacenamiento interna.
- NO sobrecargue el somier.
- NO salte sobre el producto ni sobre ninguna de sus piezas.

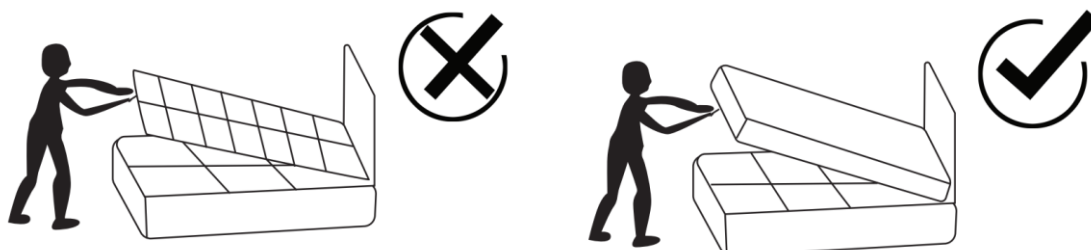



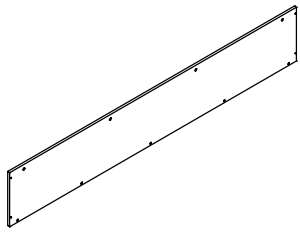
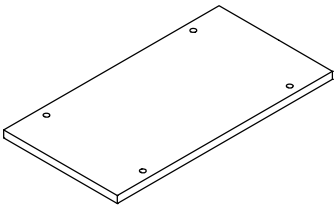
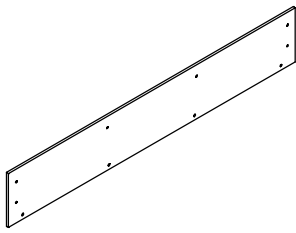
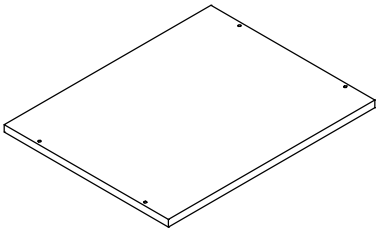
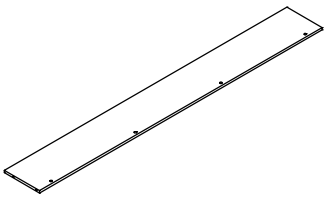
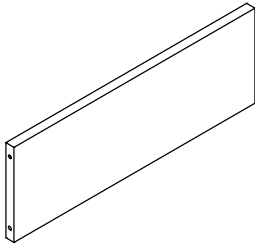
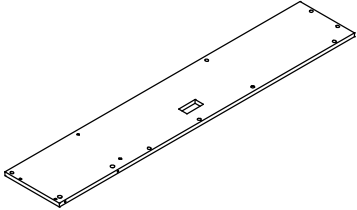
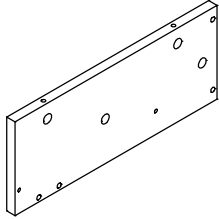
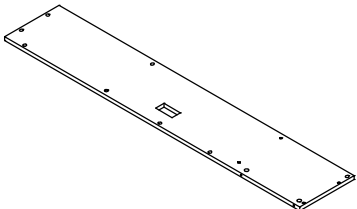
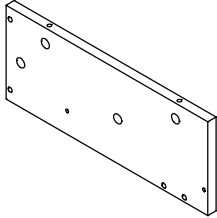
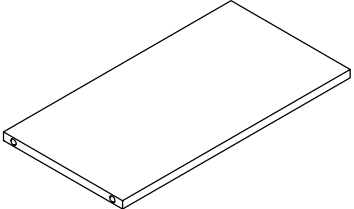
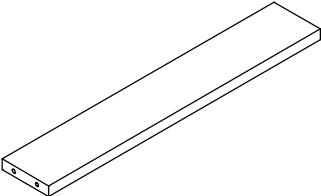

N616P308949

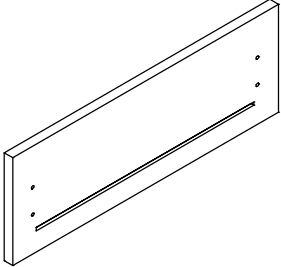
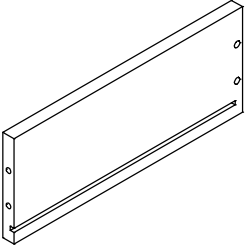
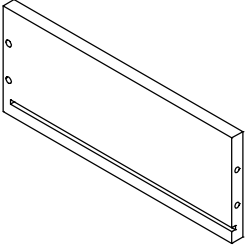
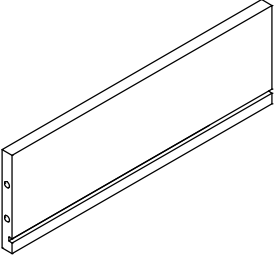
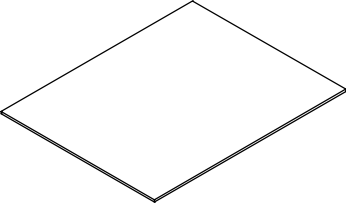
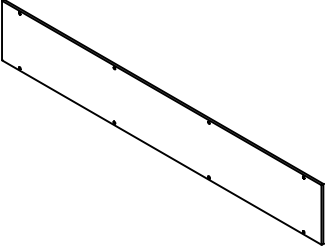
<p>1</p>		<p>X1</p>	<p>7</p>		<p>X2</p>
<p>2</p>		<p>X1</p>	<p>8</p>		<p>X2</p>
<p>3</p>		<p>X1</p>	<p>9</p>		<p>X2</p>
<p>4</p>		<p>X1</p>	<p>10</p>		<p>X2</p>
<p>5</p>		<p>X1</p>	<p>11</p>		<p>X2</p>
<p>6</p>		<p>X2</p>	<p>12</p>		<p>X2</p>



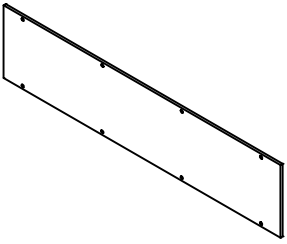
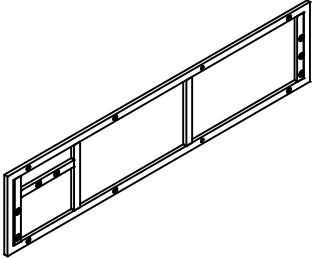
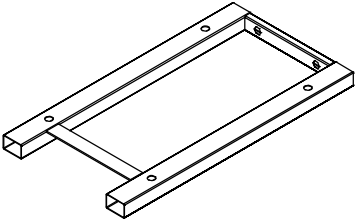
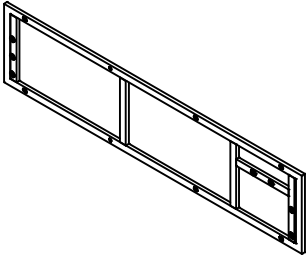
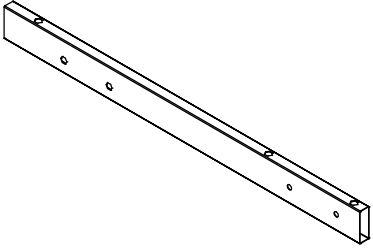
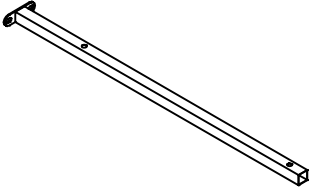
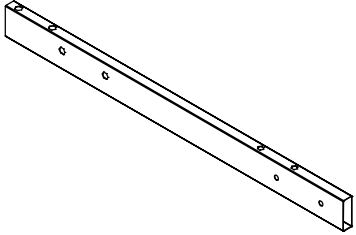

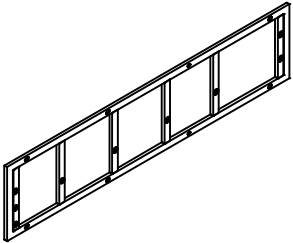
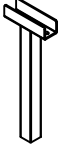
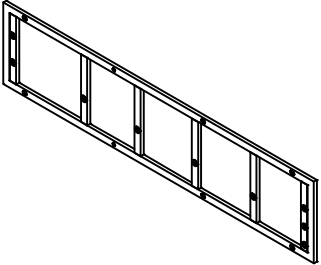

N616P308949

13		X2			
14		X2			
15		X2			
16		X2			
17		X2			
19		X1			

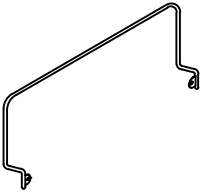
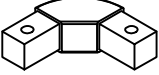
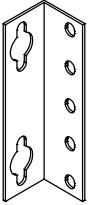
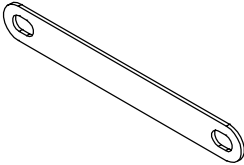
N616P308950

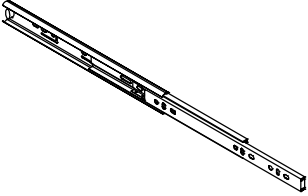
18		X4	33		X1
24		X2	34		X1
25		X1	38		X2
26		X1	40		X4
31		X1	41		X2
32		X1	42		X2

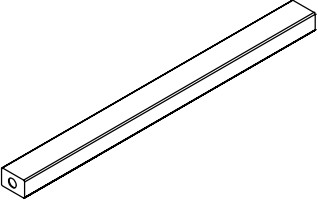
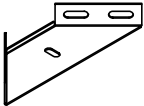
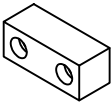

N616P308950

<p>44</p>		<p>X1</p>	<p>50</p>		<p>X4</p>
<p>45</p>		<p>X2</p>	<p>51</p>		<p>X2</p>
<p>46</p>		<p>X1</p>	<p>53</p>		<p>X4</p>
<p>47</p>		<p>X1</p>	<p>54</p>		<p>X2</p>
<p>48</p>		<p>X2</p>	<p>55</p>		<p>X2</p>
<p>49</p>		<p>X1</p>	<p>57</p>		<p>X1</p>

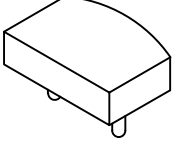
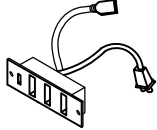
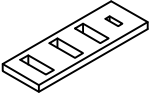
N616P308950

58		X22			
59		X2			
60		X2			

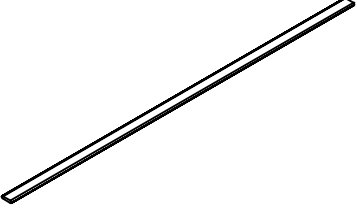
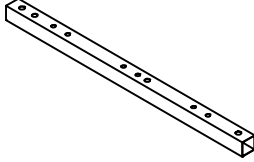
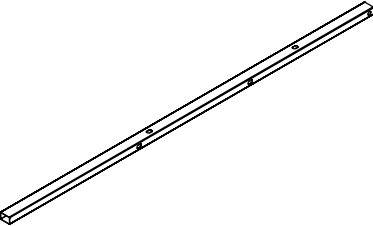
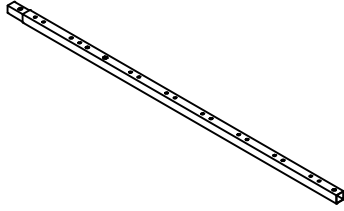
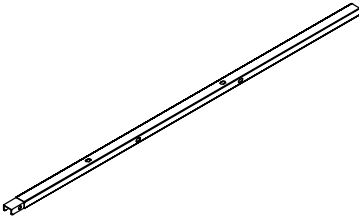
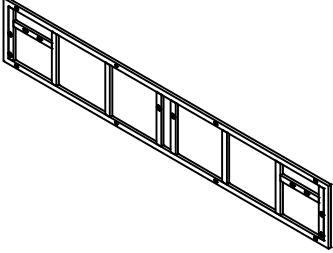
N616P308951

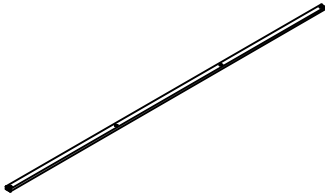
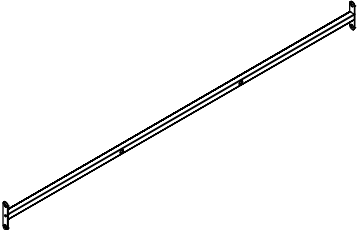
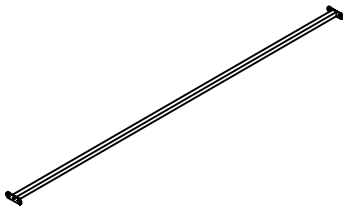
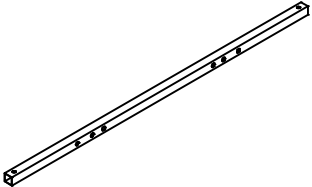
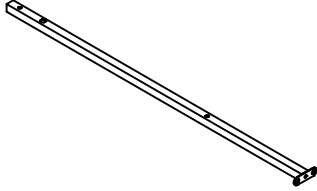



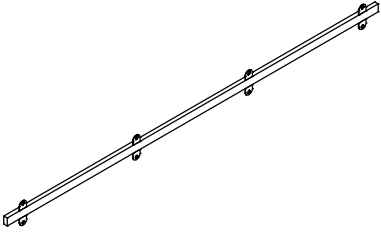
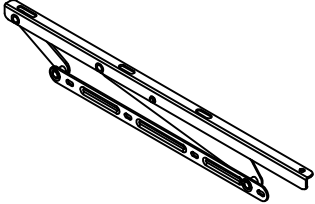
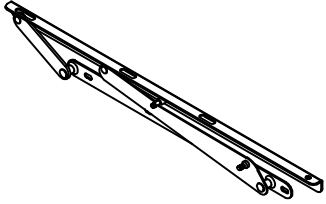
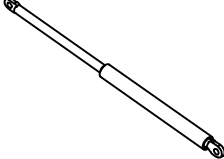





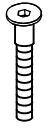

20		X11	29		X2
21		X1	30		X2
22		X1	35		X1
23		X2	36		X1
27		X2	37		X1
28		X2	39		X2

N616P308951

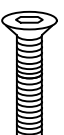
43		X1			
L		X1			
R		X1			
52		X2			

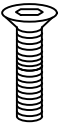
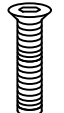

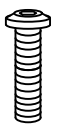

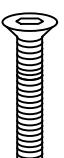
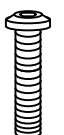
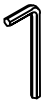





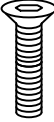

Hardware List-Hardware-Liste-Liste du matériel

N616P308950

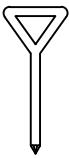
A	 M6*10	X8+1	J	 M8*13	X48+2	P	 M5*35	X36+2
C	 M6*20	X44+2	K	 M8*15	X14+1	R	 M8	X12+1
D	 M6*40	X5+1	L	 M8*20	X8+1	S	 M3*12	X20+2
E	 M6*30	X18+1	M	 M8*30	X8+1	T	 M3*12	X20+2
F	 M6*28	X6+1	N	 M8*35	X12+1	U	 M3*12	X20+2
G	 M6*50	X8+1	O	 M8*45	X8+1	V	 M5	X1

Hardware List-Hardware-Liste-Liste du matériel

N616P308950

	 M6	X1		 M6*25	X4+1				
	 M8	X1							
		X1							
		X1							
	 M8*φ22	X10+1							
	 Silent sticker	X12+1							

3

M6X20
CX2pcs

M6X30
EX1pcs

M6
WX1pc

M5*35
PX2pcs

M5
VX1pc

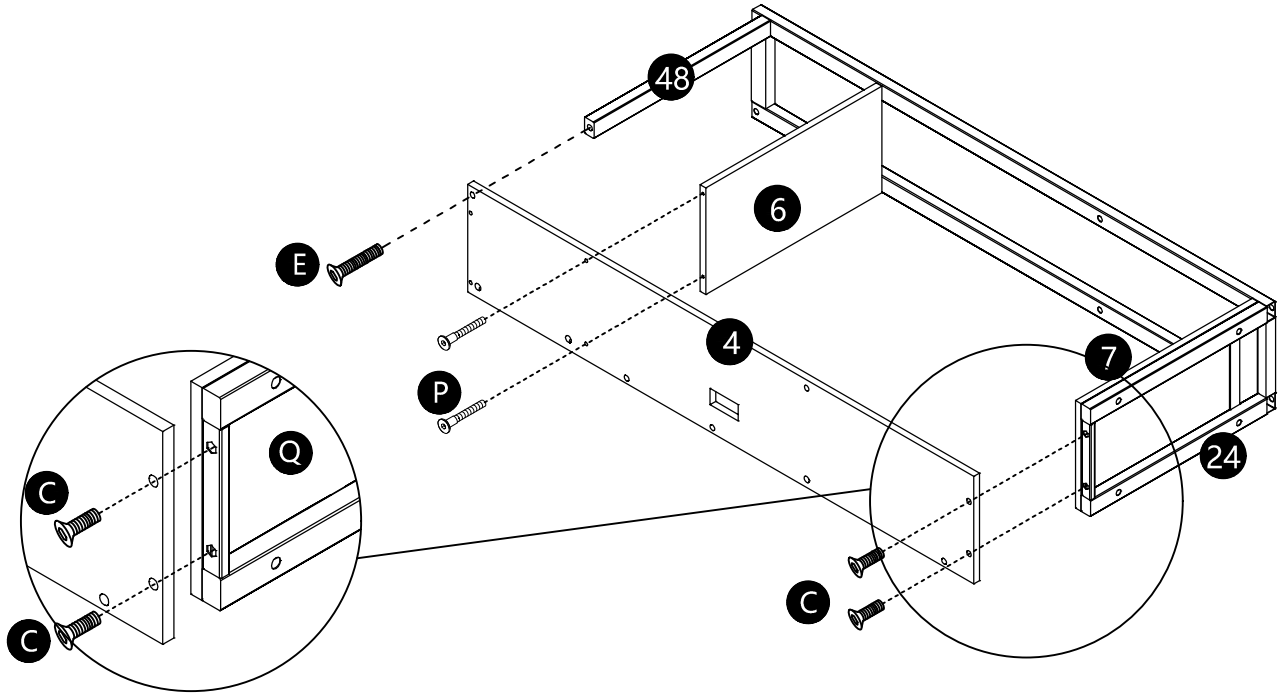

4

M6X50
GX3pcs

M6
WX1pc

M5*35
PX2pcs

M5
VX1pc

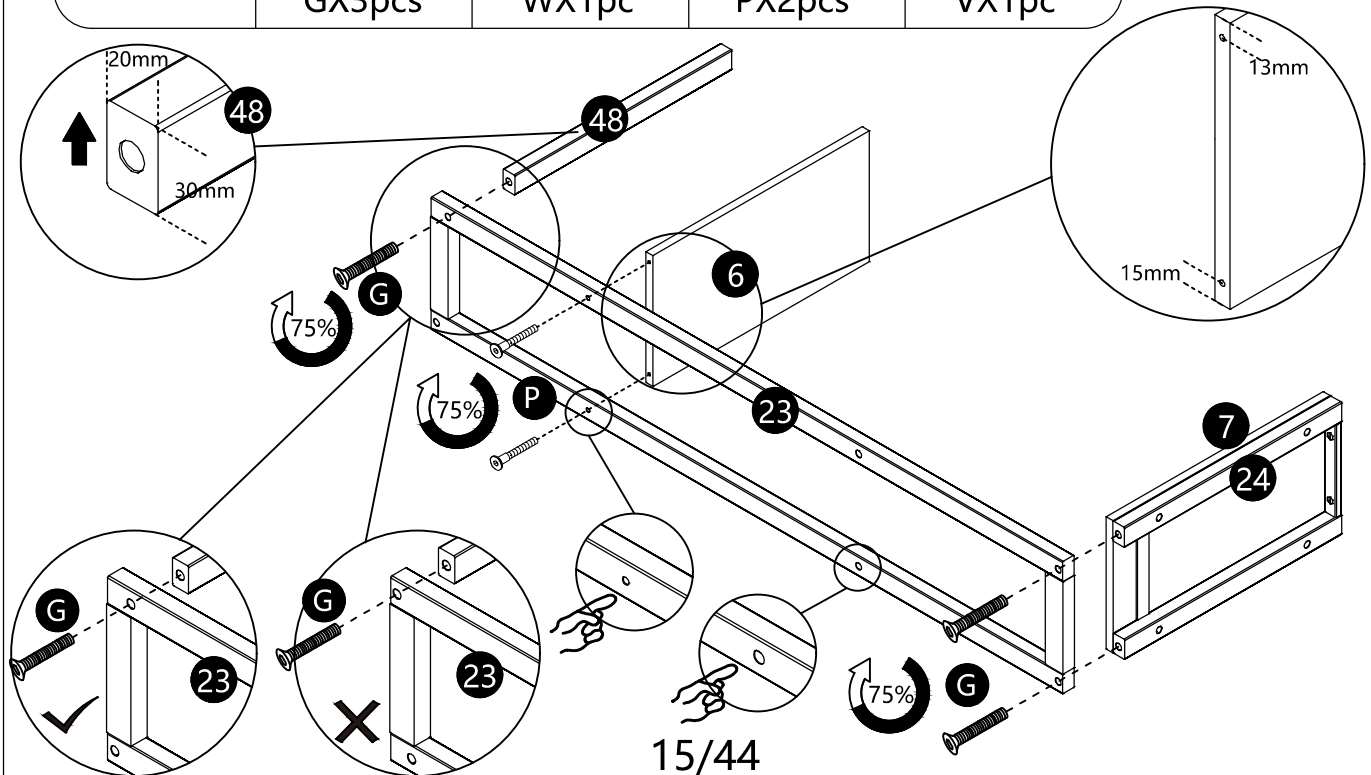

5



M6X20
CX2pcs



M6X30
EX1pcs

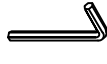

M6
WX1pc

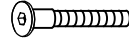

M5*35
PX2pcs

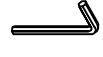

M5
VX1pc

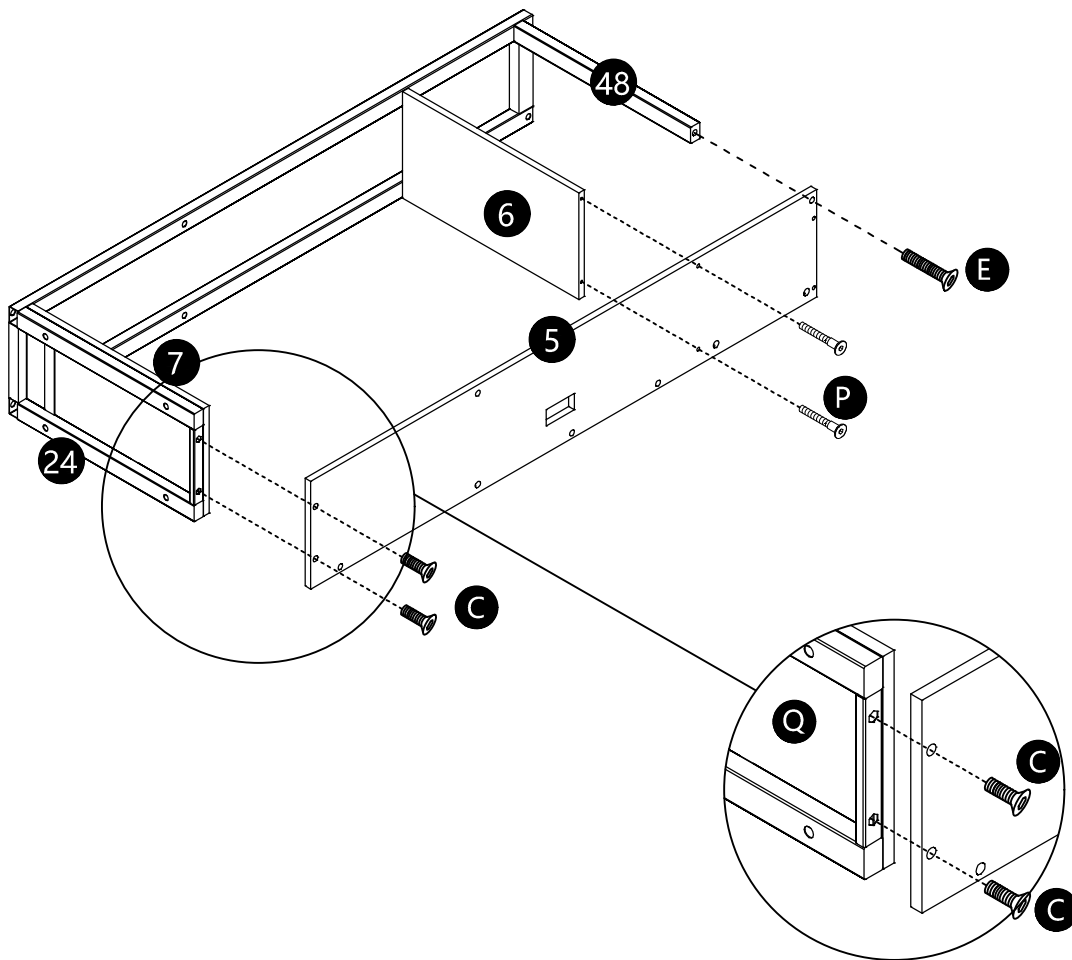

6

53

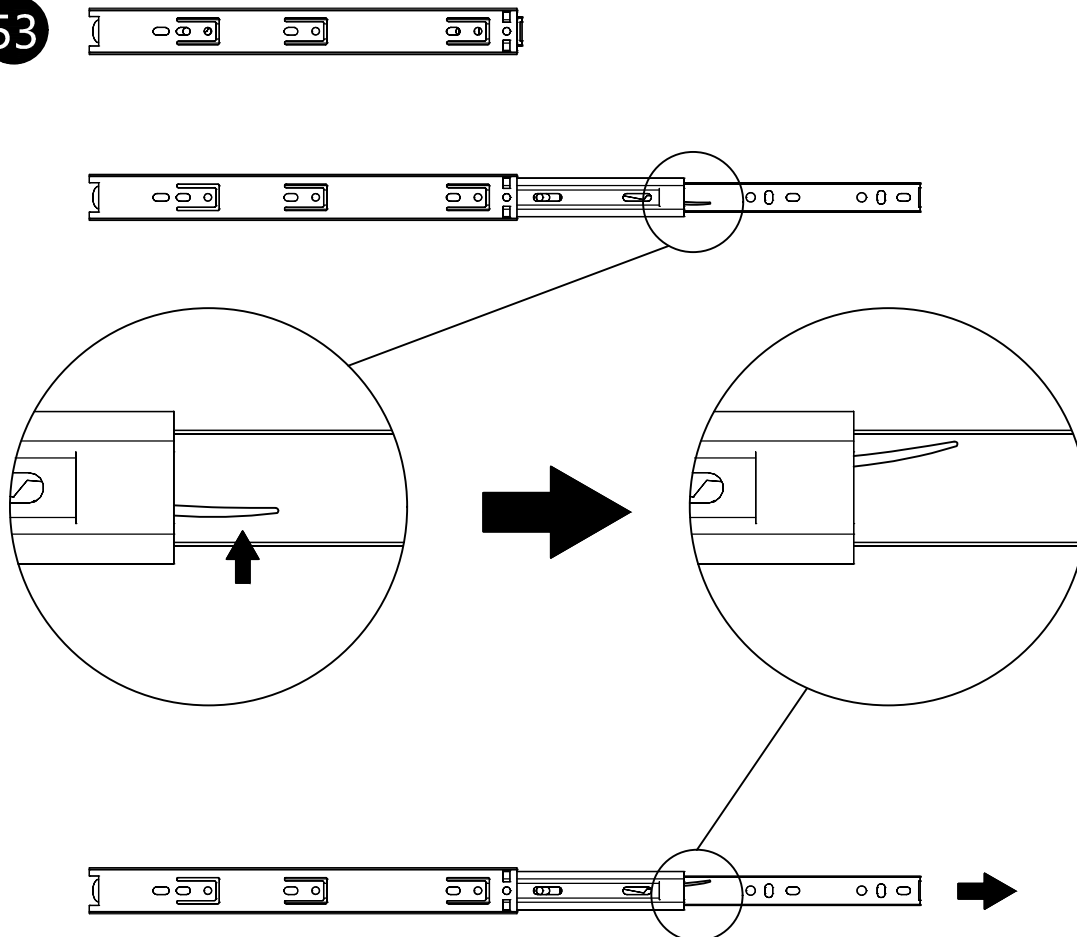

- * As shown in the diagram, push upward on the indicated area so that part B can be pulled out from part A.
- * Wie im Diagramm gezeigt, drücken Sie auf den angezeigten Bereich nach oben, so dass das Teil B aus dem Teil A herausgezogen werden kann.
- * Comme le montre le schéma, pousser vers le haut sur la zone indiquée pour que la partie B puisse être extraite de la partie A.
- * Como se muestra en el diagrama, empuje hacia arriba en la zona indicada para que la parte B pueda sacarse de la parte A.
- * Come mostrato nel diagramma, spingere verso l'alto sull'area indicata in modo che la parte B possa essere estratta dalla parte A.

53 - A

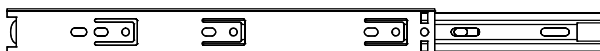

53 - B

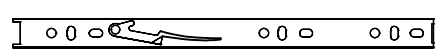

7

M3*12
SX4pcs

YX1pc

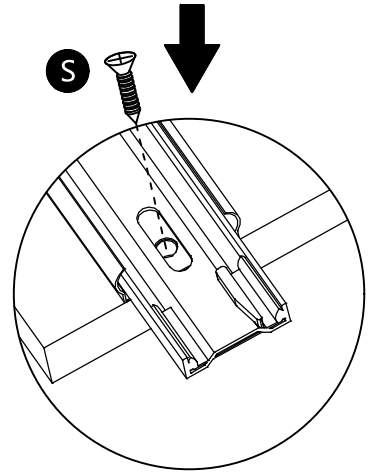
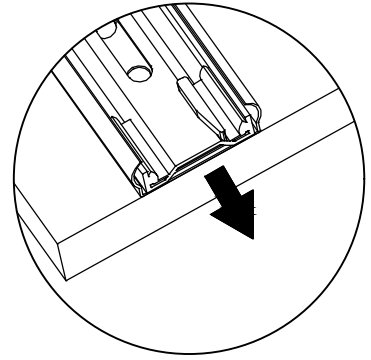
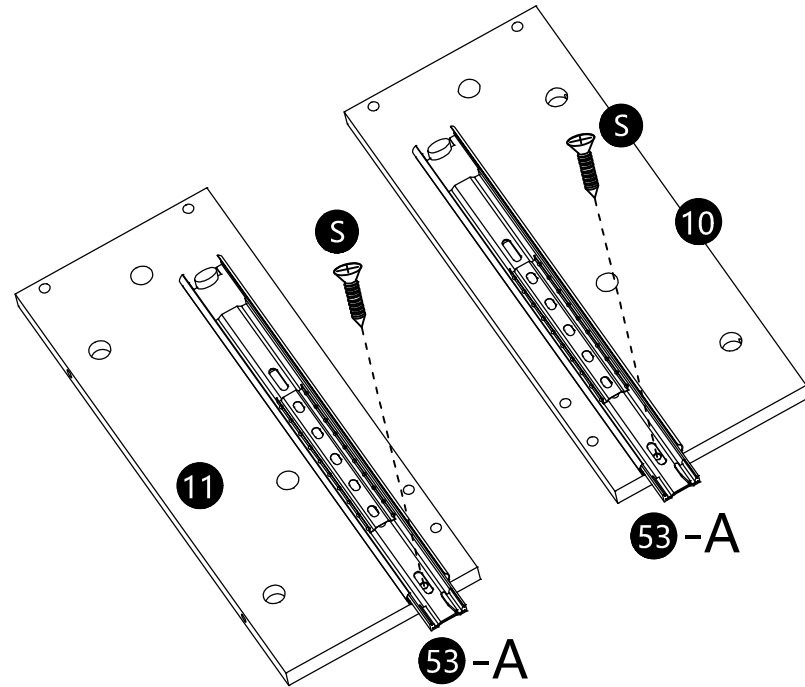

X2

8

M3*12
SX4pcs

YX1pc

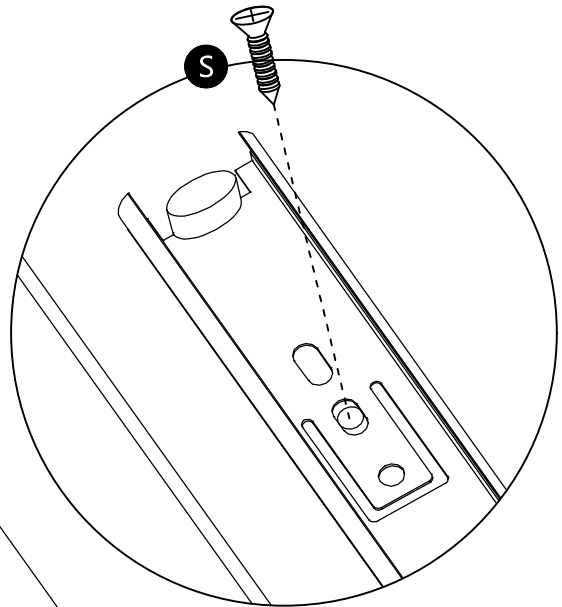
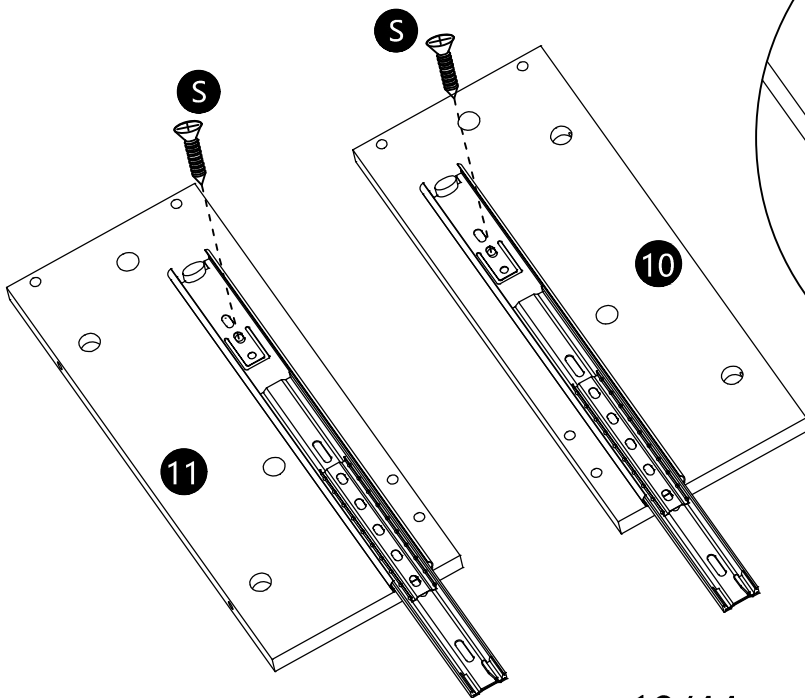

X2

9

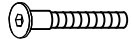

M5*35
PX8pcs



M5
VX1pc

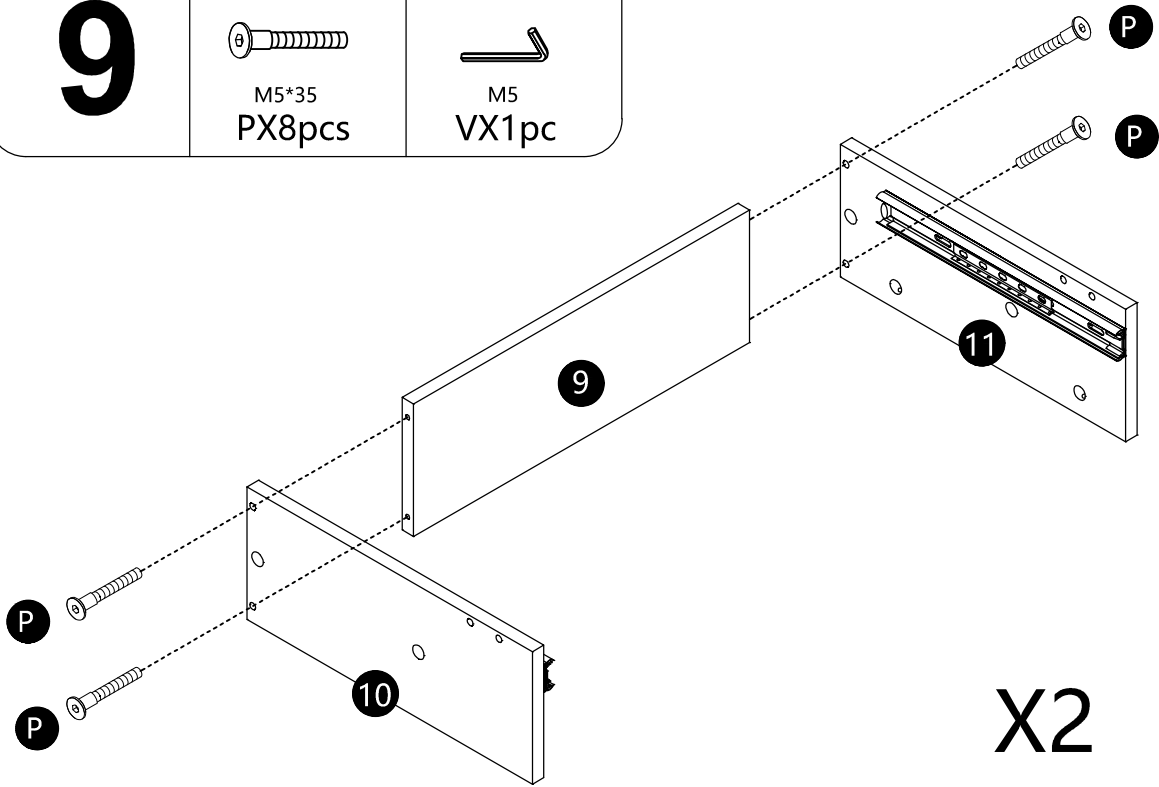

10

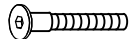

M5*35
PX8pcs



M5
VX1pc

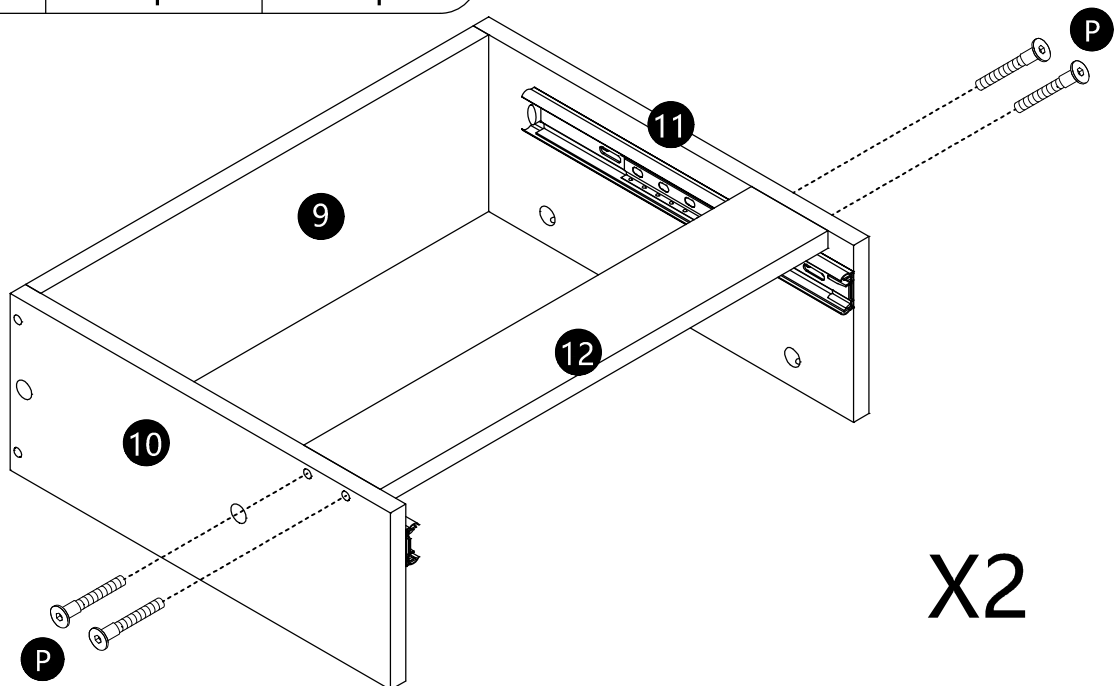

11

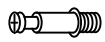

TX8pcs

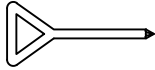

YX1pc

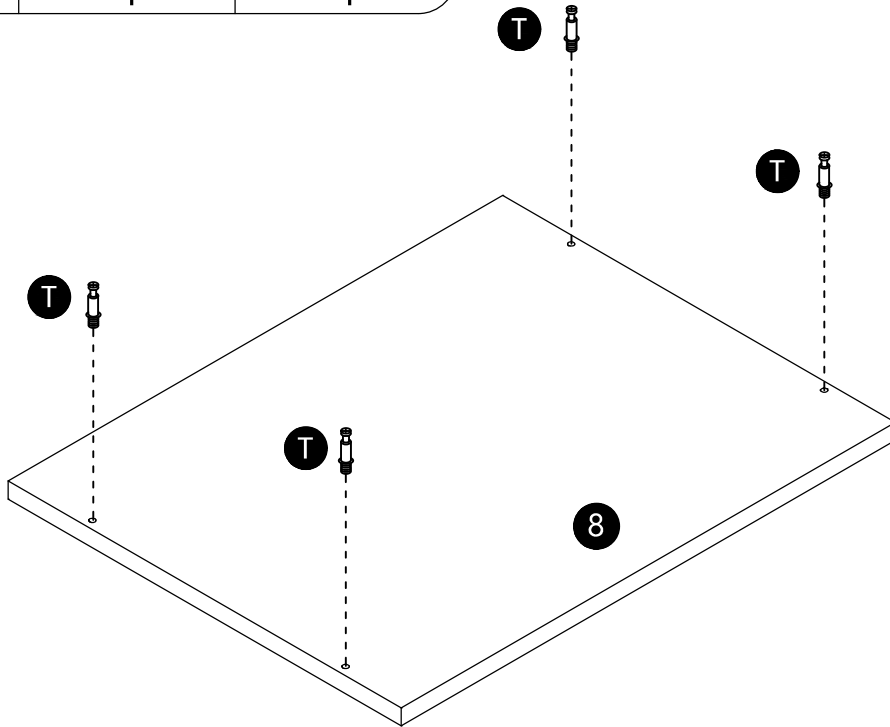

X2

12



UX8pcs

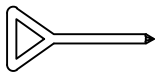

YX1pc

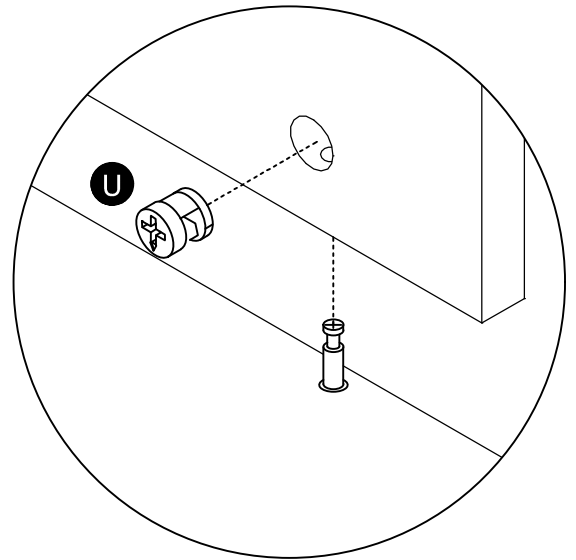
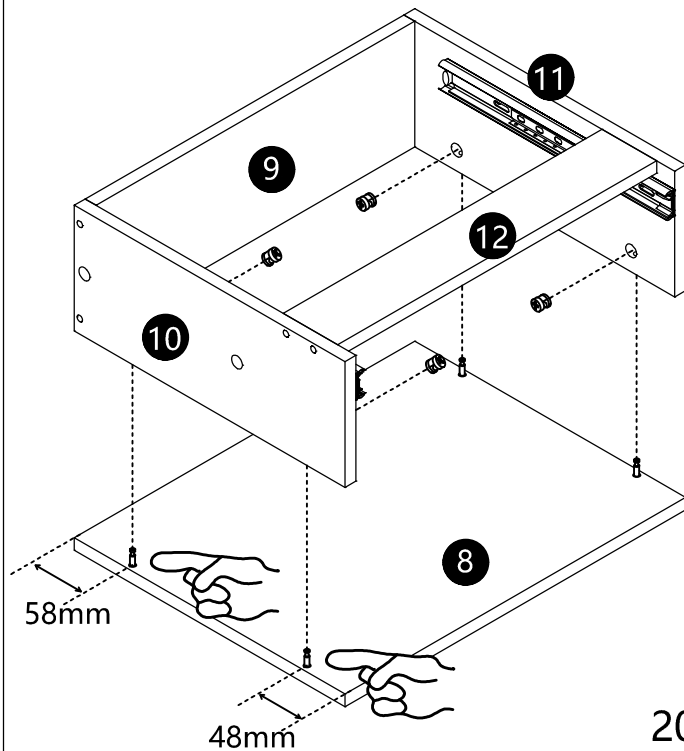

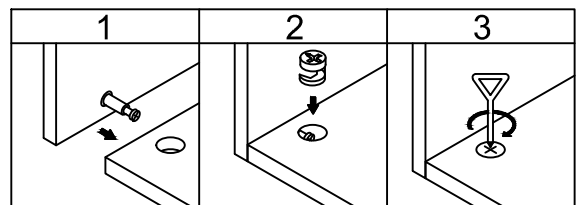

X2

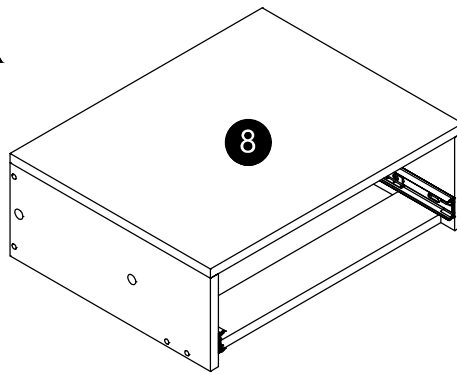
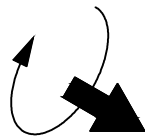
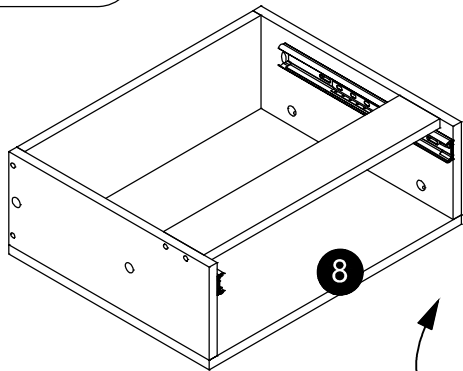

13

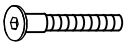

X2

<h1>14</h1>		
	M5*35 PX8pcs	M5 VX1pc

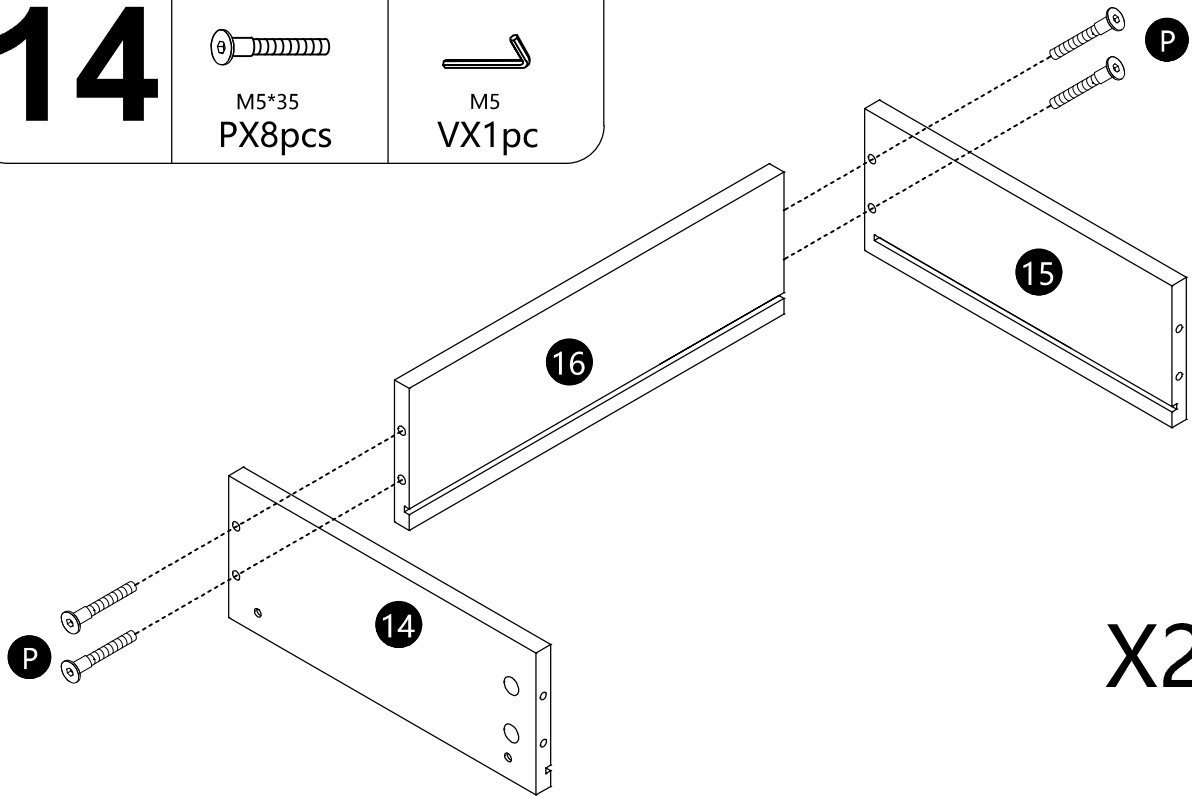

X2

15

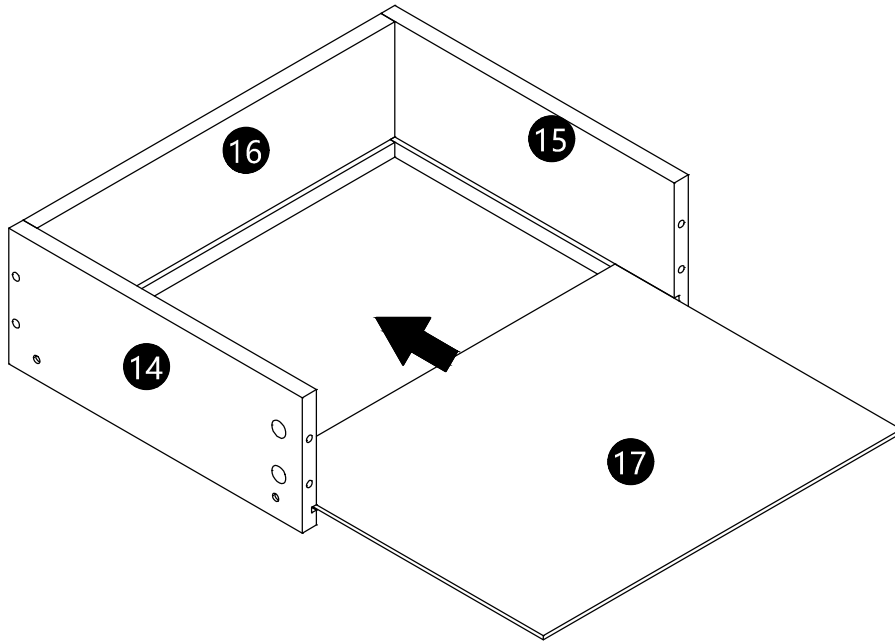

X2

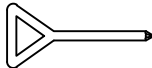
16		
	TX8pcs	YX1pc

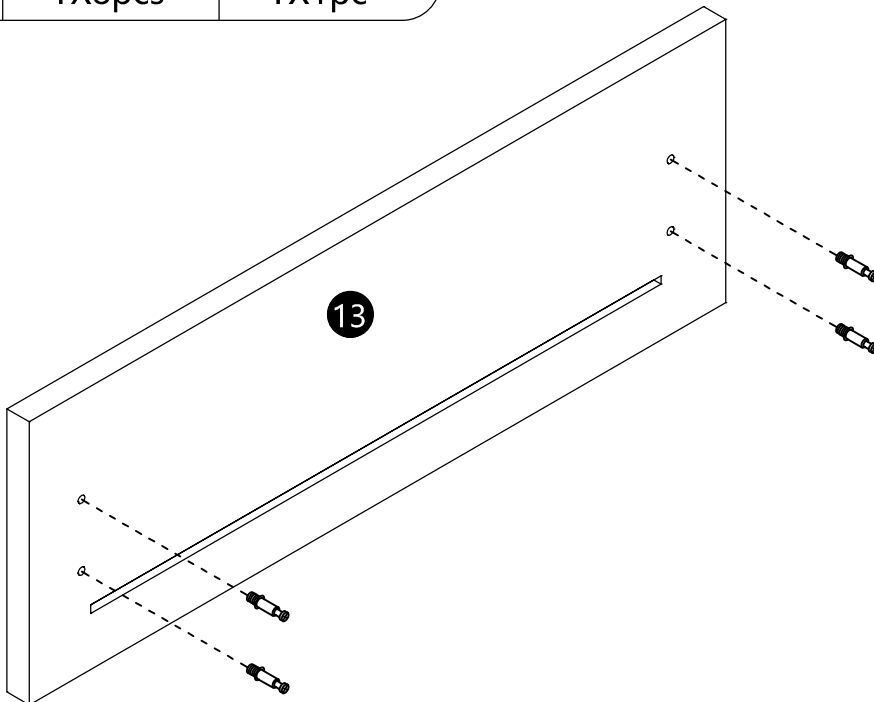

X2

17



UX8pcs

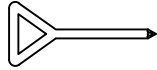

YX1pc

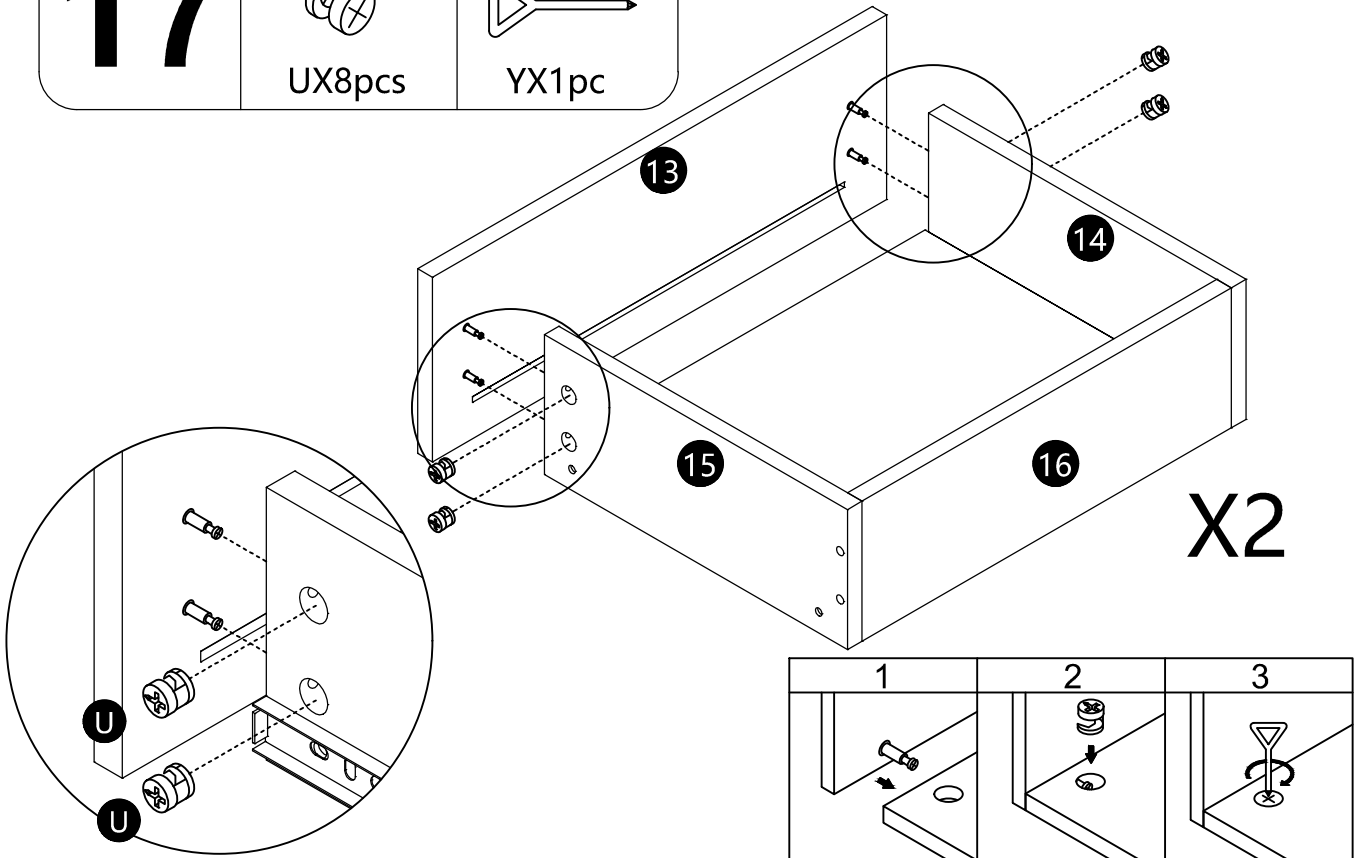

18



M3*12
SX8pcs

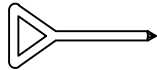

YX1pc

X2

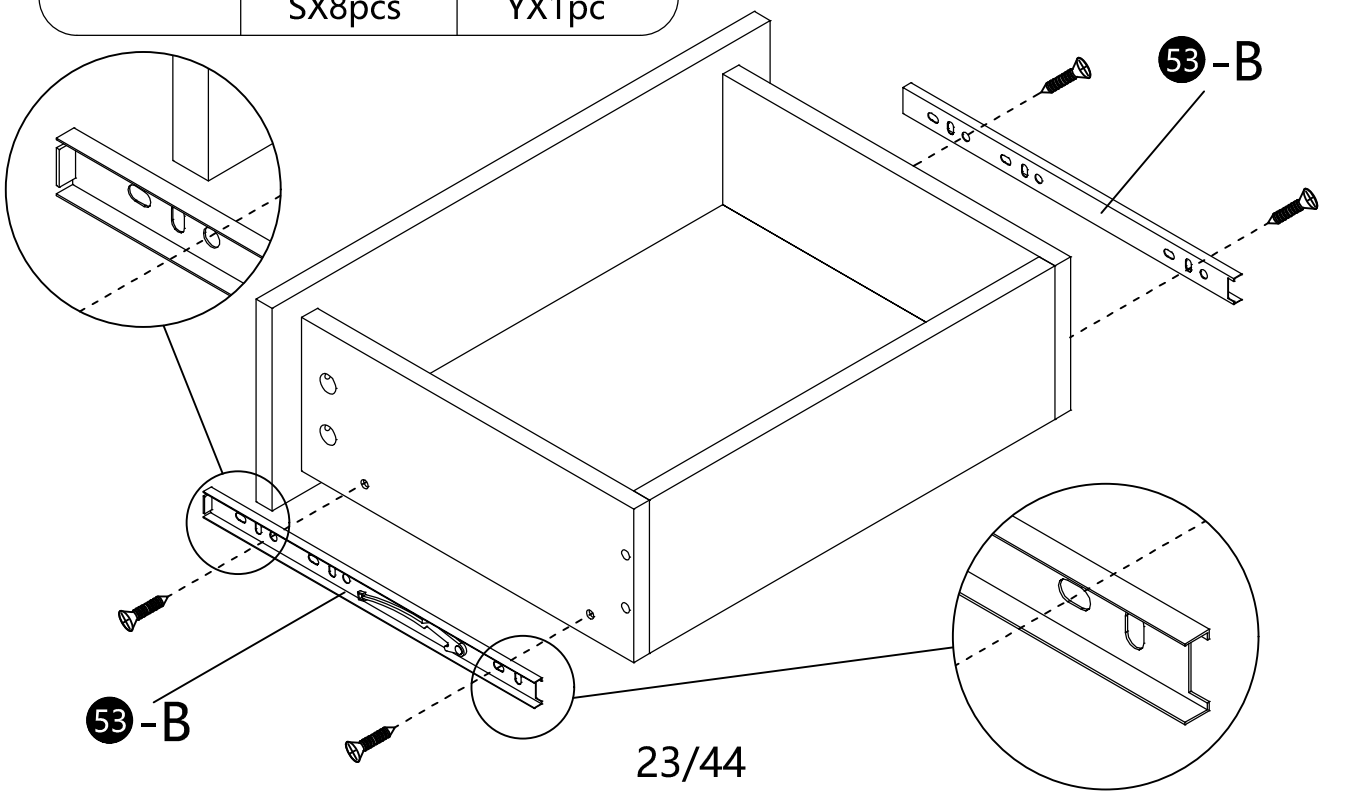

19

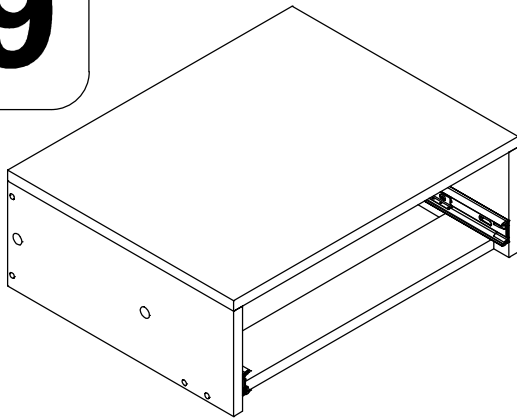

X2

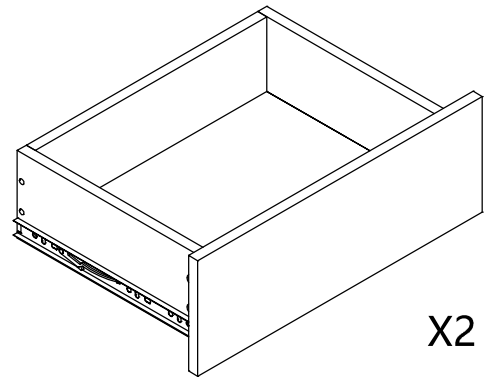

X2

- * Assemble the second drawer combination in the same way.
- * Montage der zweiten Schubladenkombination auf die gleiche Weise
- * Assemblez la deuxième combinaison de tiroir de la même manière
- * Montar la segunda combinación de cajones de la misma manera
- * Montare la seconda combinazione cassetti nello stesso modo

20



M6X25
A3X4pcs



M6X30
EX4pcs

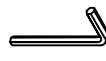

M6
WX1pc

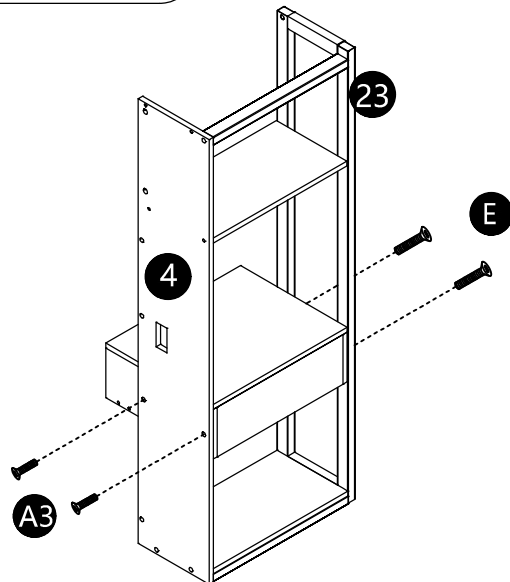
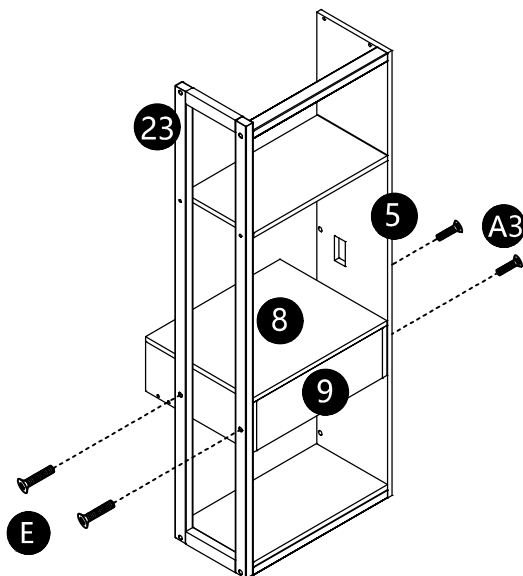

- * After completion, tighten the screws of steps 2 and 4 completely
- * Nach Abschluss die Schrauben der Schritte 2 und 4 vollständig festziehen
- * Après avoir terminé, serrez complètement les vis des étapes 2 et 4
- * Después de terminar, apriete los tornillos de los pasos 2 y 4 completamente
- * Dopo il completamento, stringere completamente le viti dei passaggi 2 e 4

21



M8*20
LX8pcs



M8
XX1pc

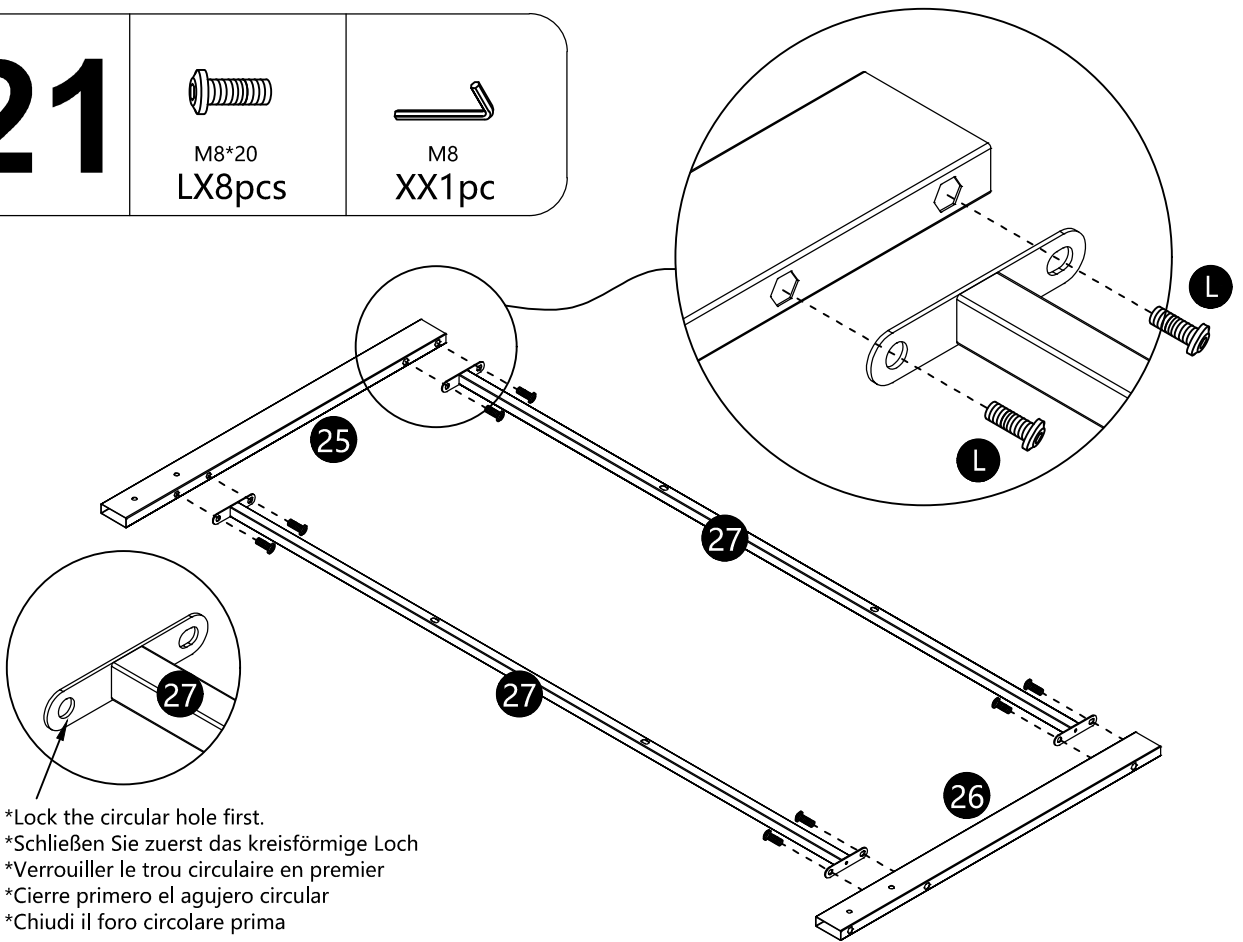

- *Lock the circular hole first.
- *Schließen Sie zuerst das kreisförmige Loch
- *Verrouiller le trou circulaire en premier
- *Cierre primero el agujero circular
- *Chiudi il foro circolare prima

22



M8*30
MX6pcs



M8
XX1pc

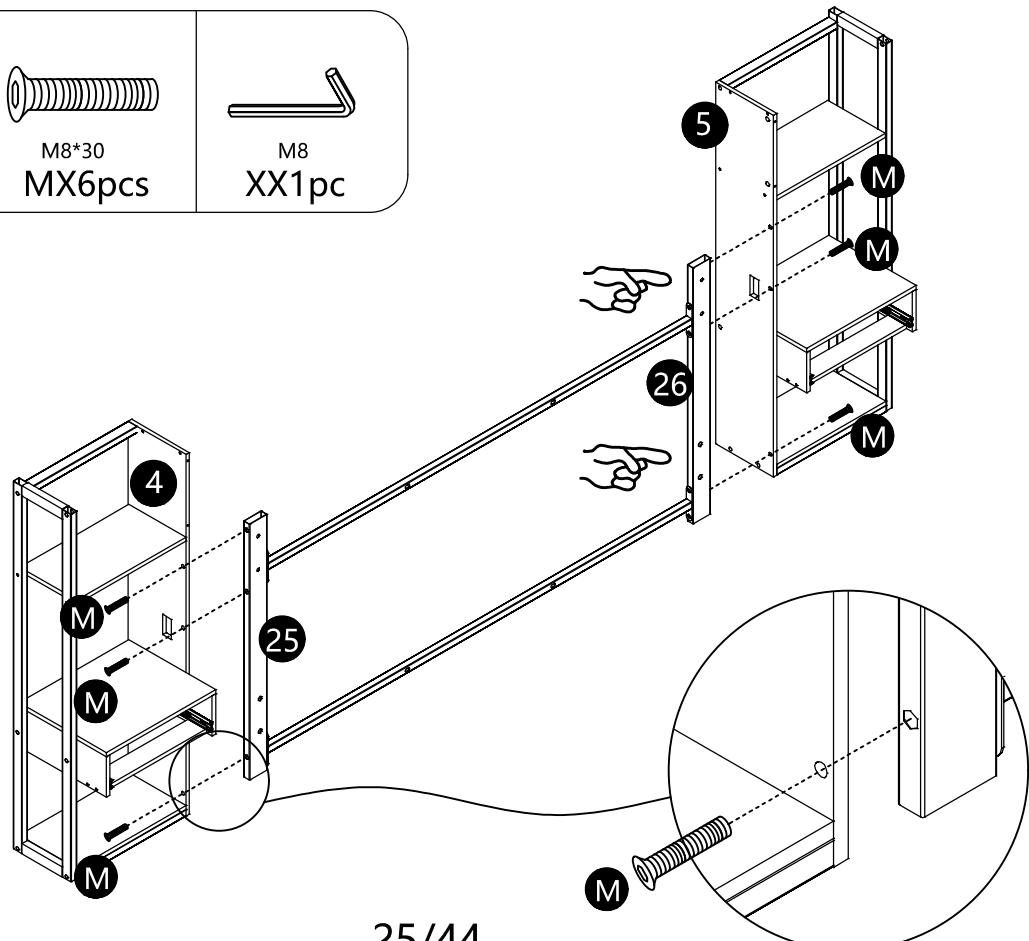

23



M6X28
FX6pcs



M6
WX1pc

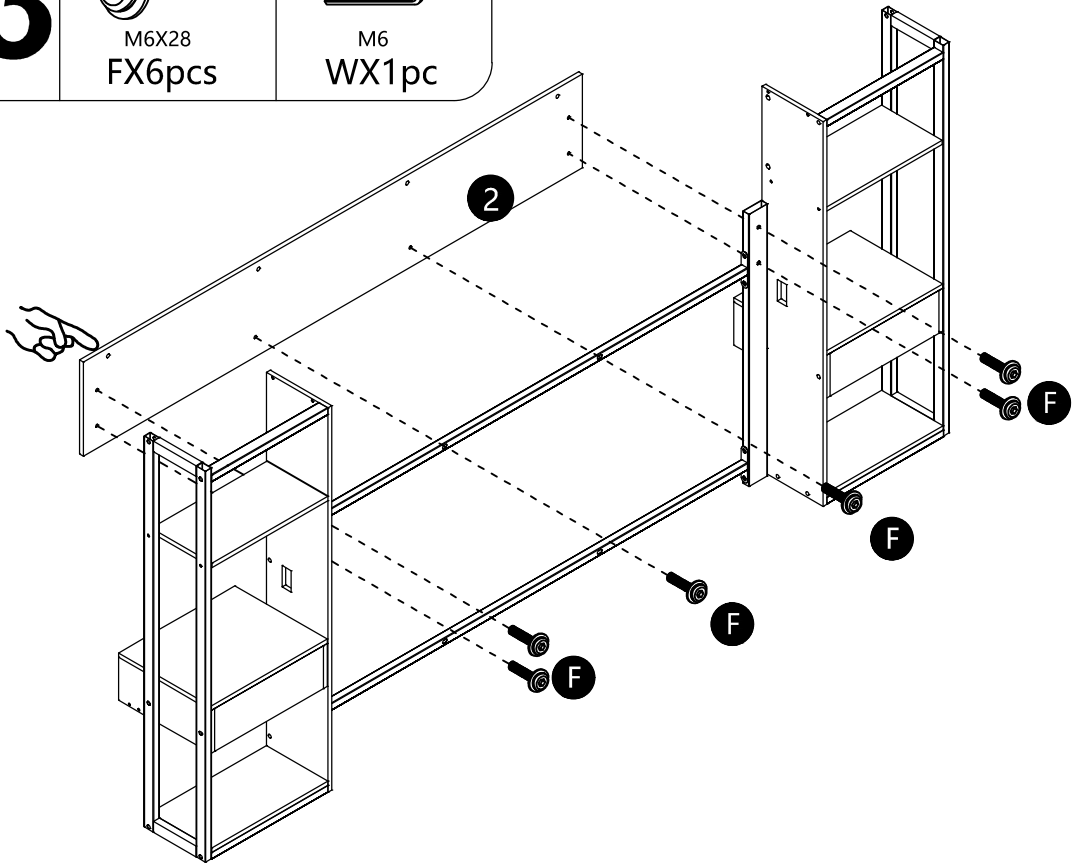

24

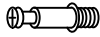

TX4pcs

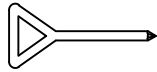

YX1pc

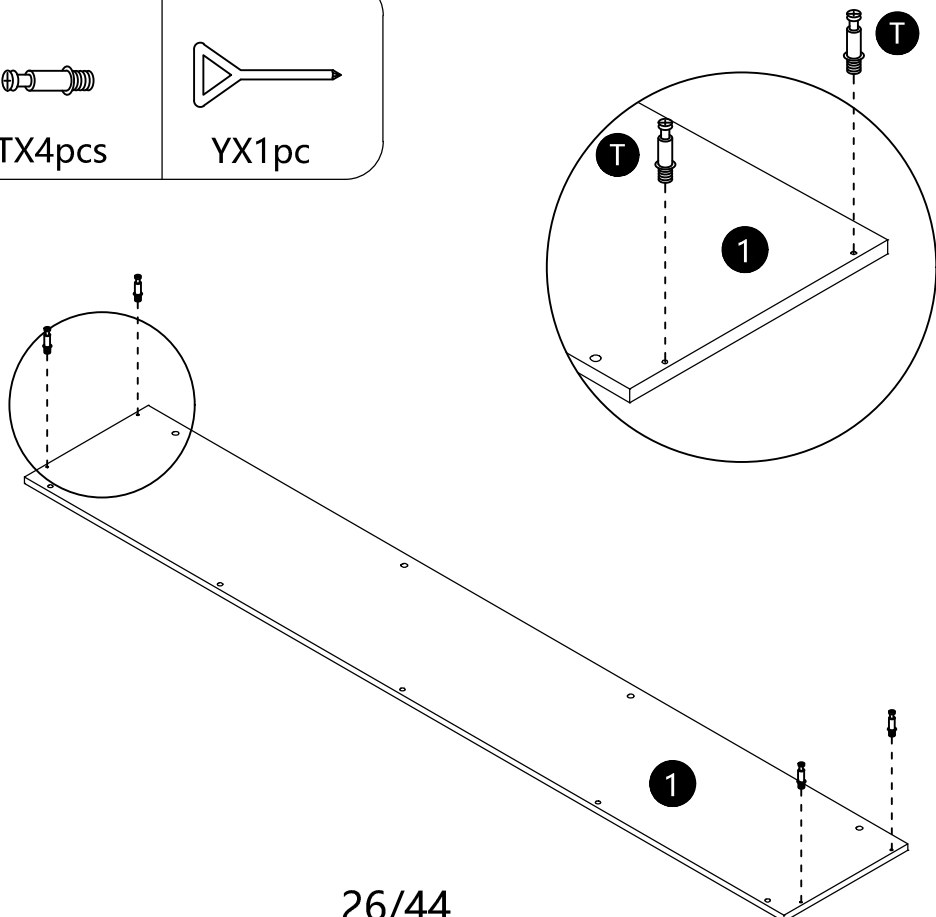

25



UX4pcs

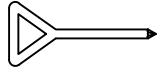

YX1pc

- * One end of the 5 screw holes is on top
- * Ein Ende der 5 Schraubenlöcher ist oben
- * Une extrémité des 5 trous à vis est au dessus
- * Un extremo de los 5 orificios de tornillo está en la parte superior
- * Una estremità dei 5 fori a vite è sulla parte superiore

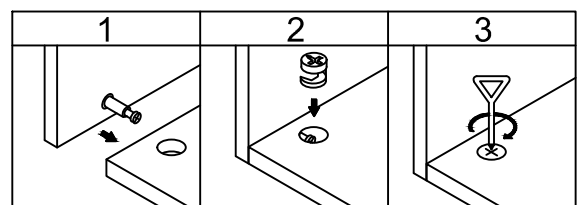
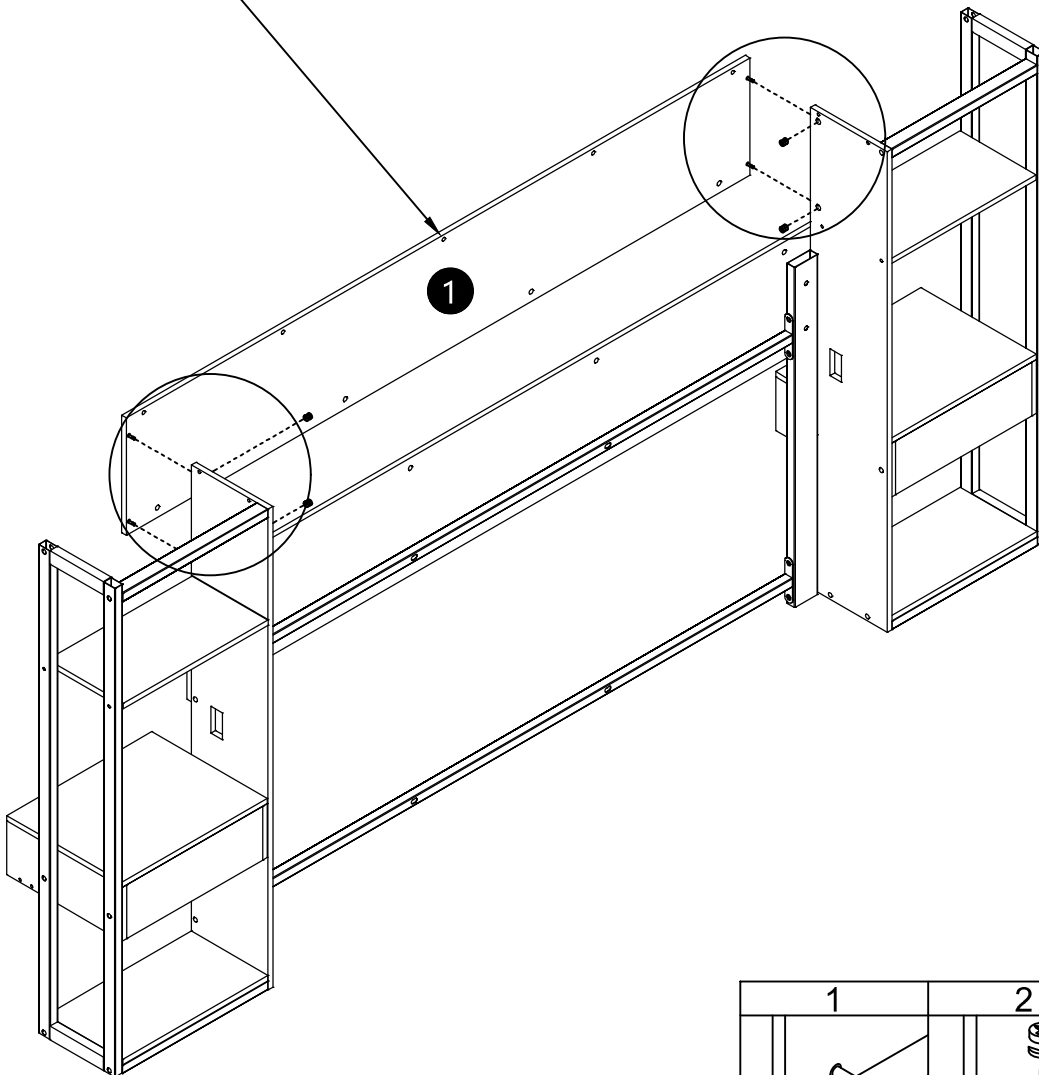
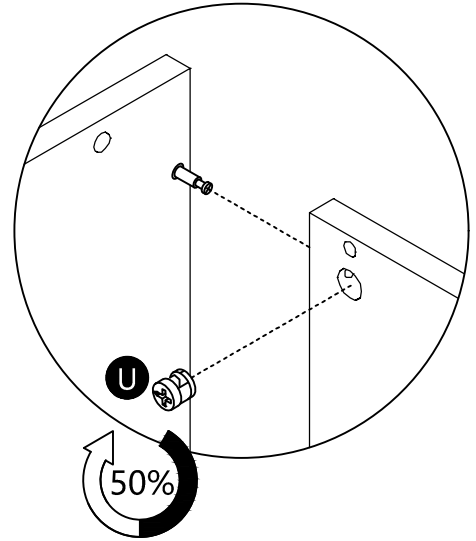

26

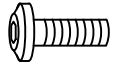

M6X10
AX8pcs



M6
WX1pc

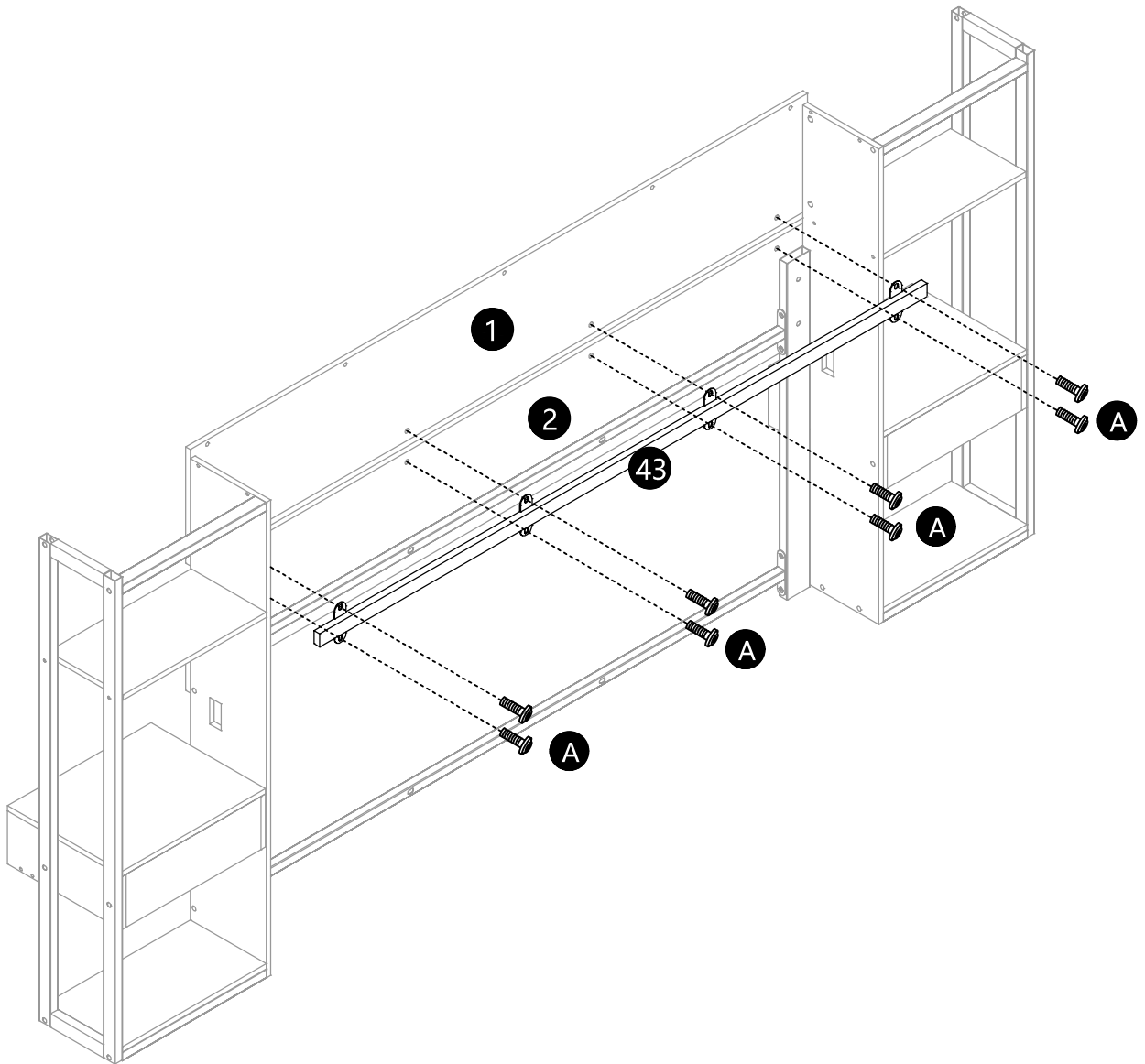

27

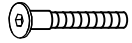

M5*35
PX4pcs



M5
VX1pc

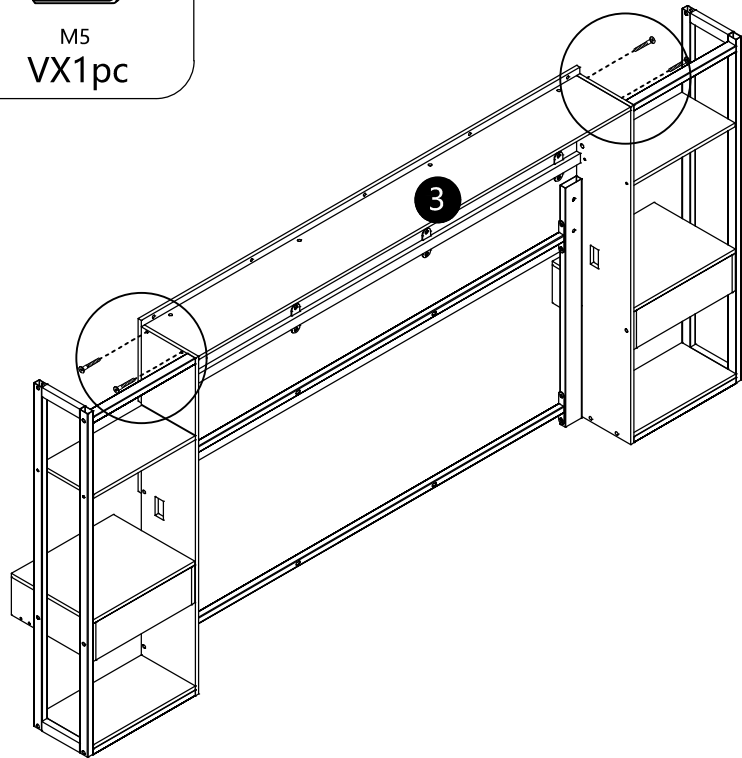
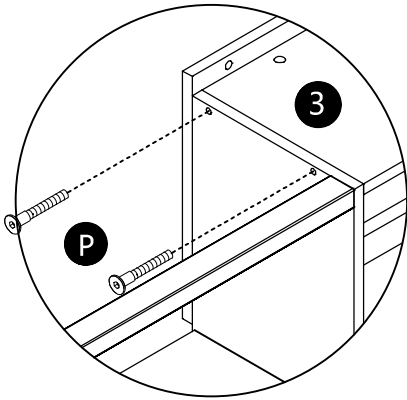

28

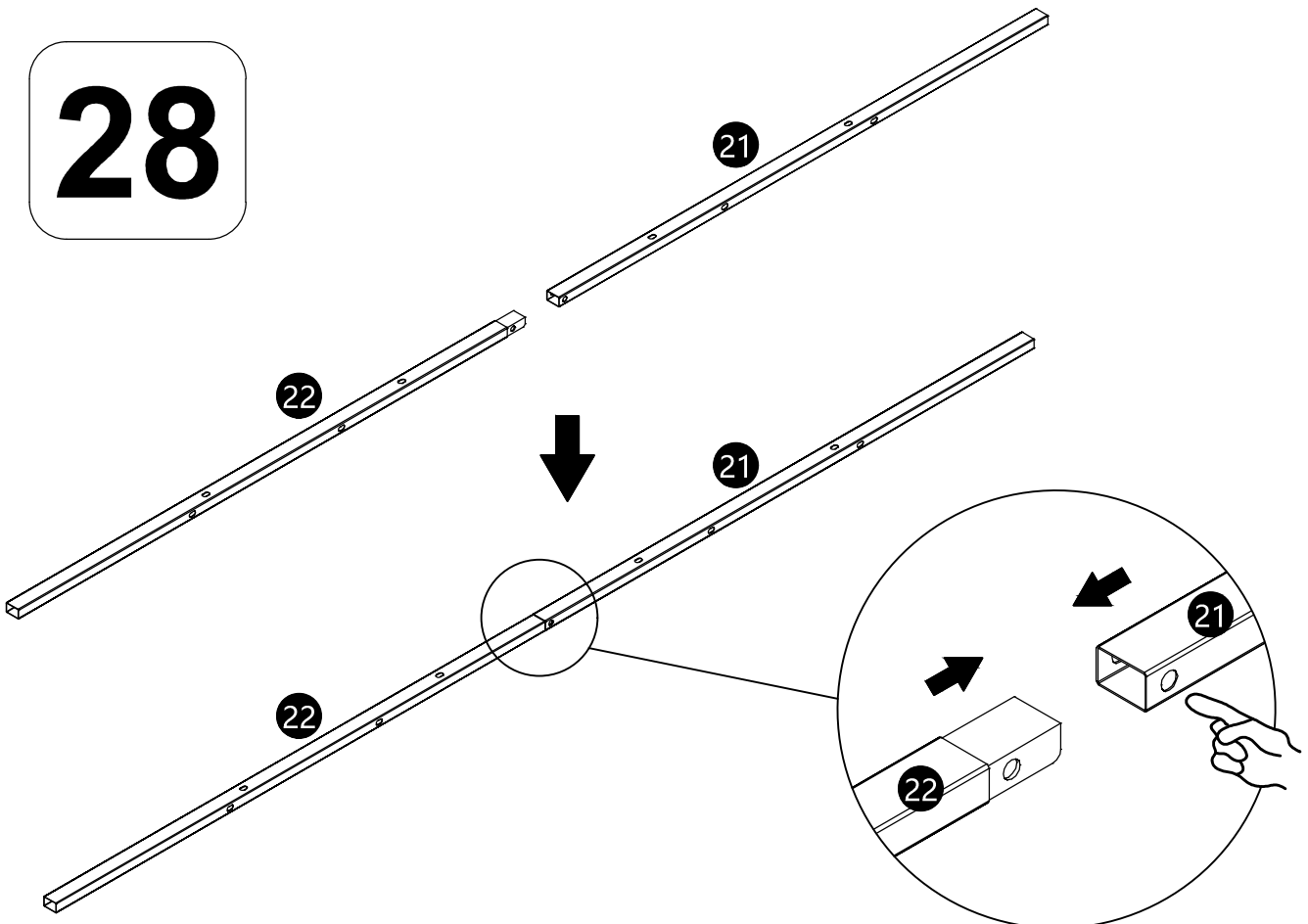

29



M6*30
EX4pcs



M6
WX1pc

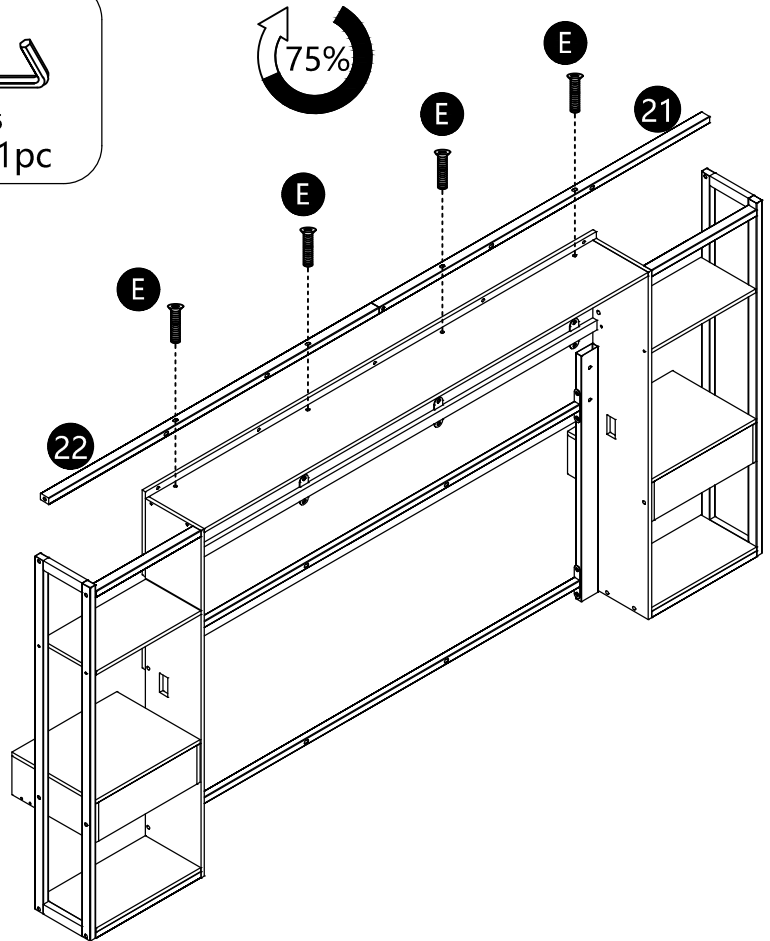

30



M6X40
DX5pcs



M6
WX1pc

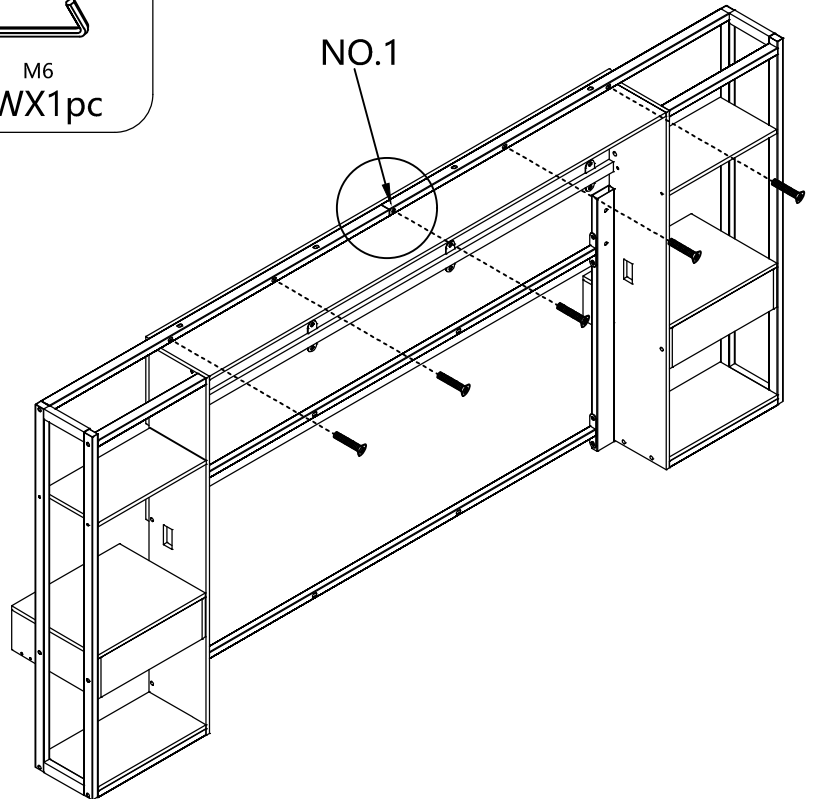
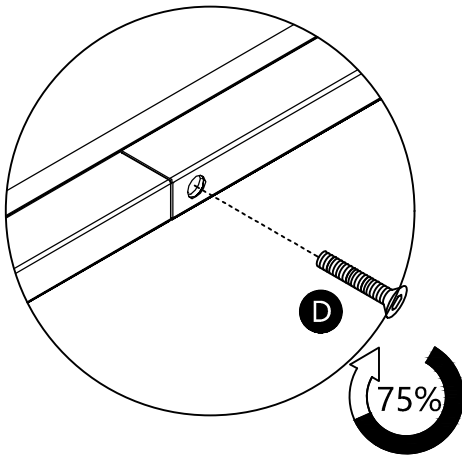

31



M6X50
GX2pcs



M6
WX1pc

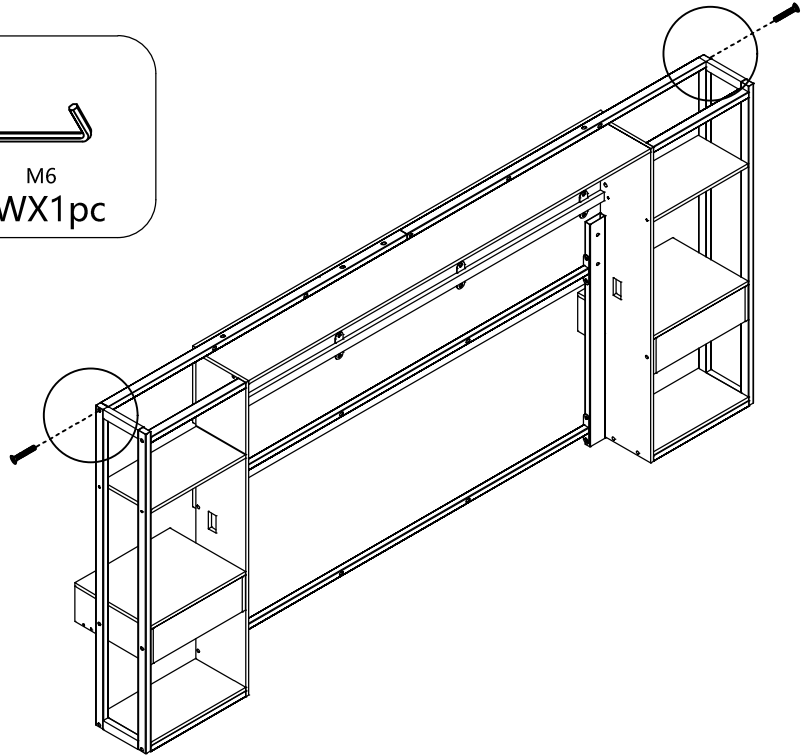
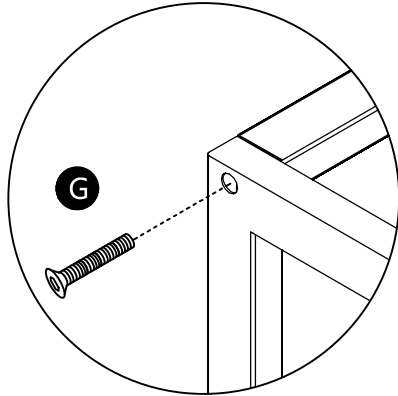

- * After completion, tighten the screws of the first two steps completely
- * Nach Fertigstellung ziehen Sie die Schrauben der ersten beiden Schritte vollständig an
- * Après avoir terminé, serrez complètement les vis des deux premières étapes
- * Después de terminar, apriete los tornillos de los primeros dos pasos completamente
- * Dopo il completamento, stringere completamente le viti dei primi due passaggi

32

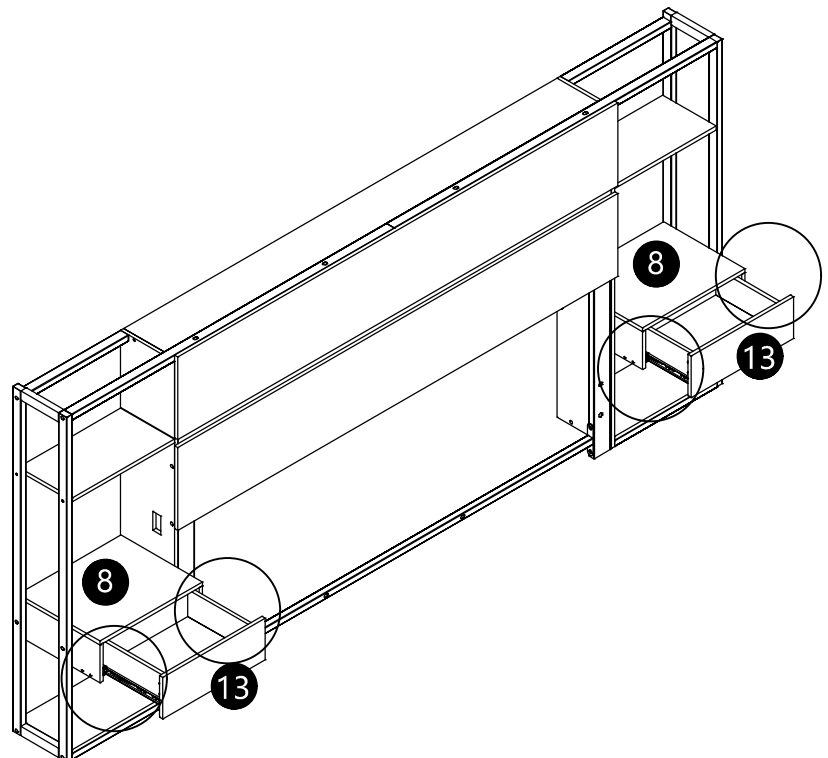
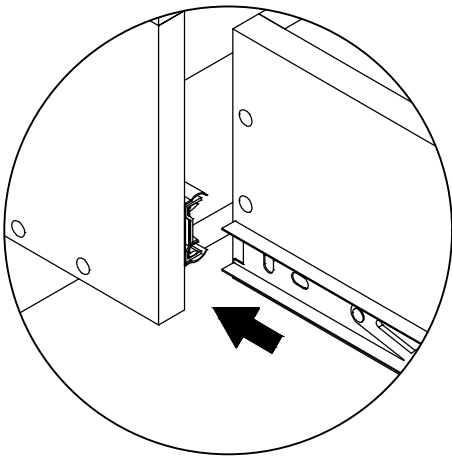

31/44

33

M3*12
SX4pcs

YX1pc

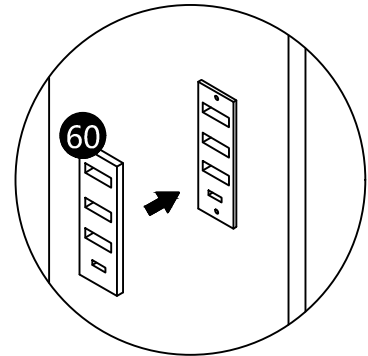
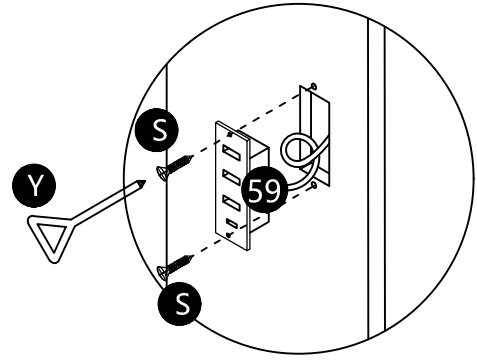
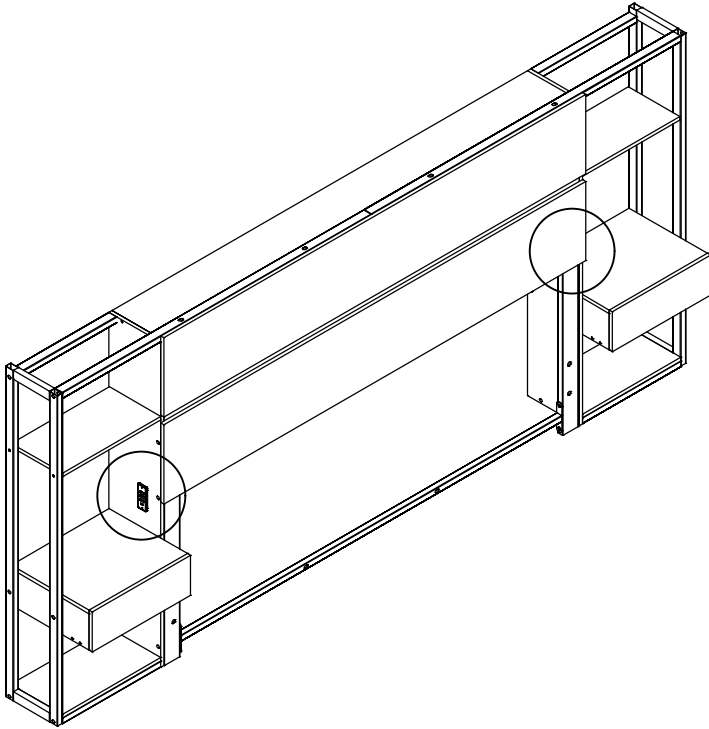

34

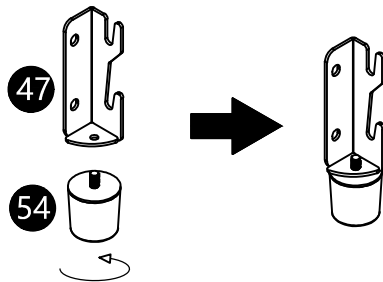
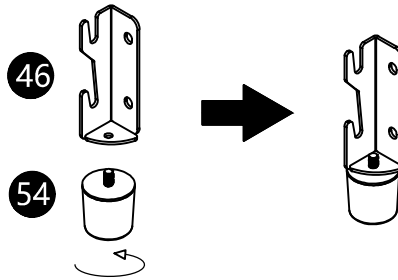

35

M8X13
JX8pcs

M8
XX1pc

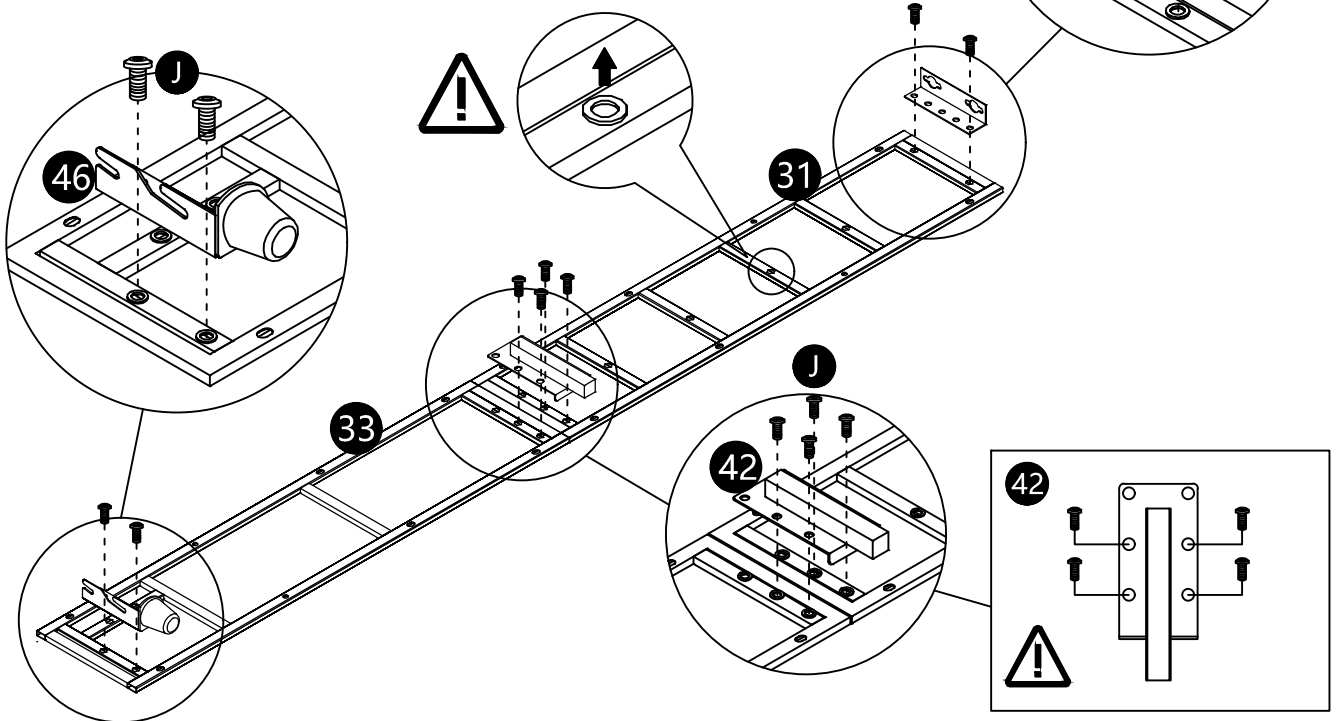

36

M8X13
JX8pcs

M8
XX1pc

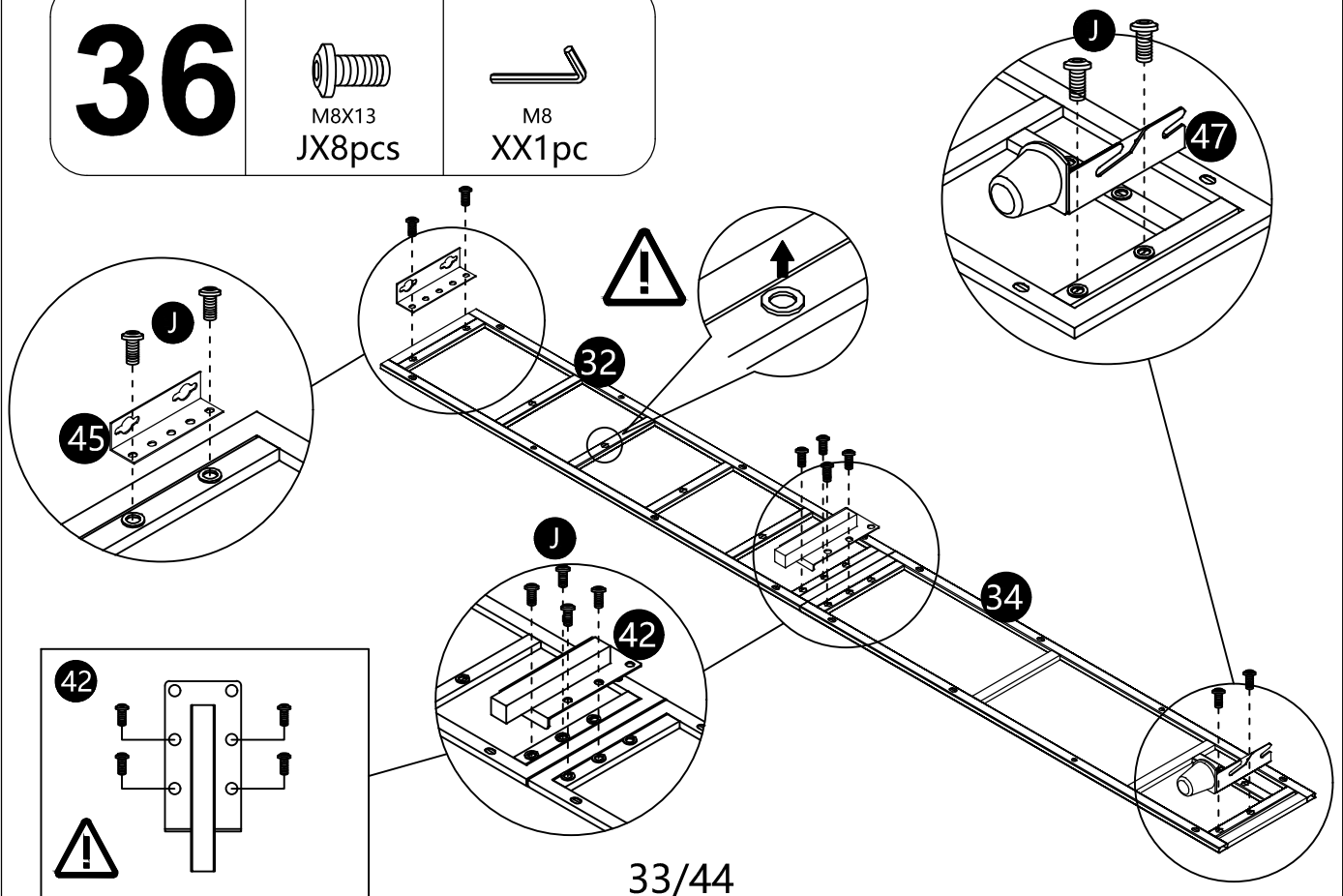

37

M8X13
JX8pcs

M8
XX1pc

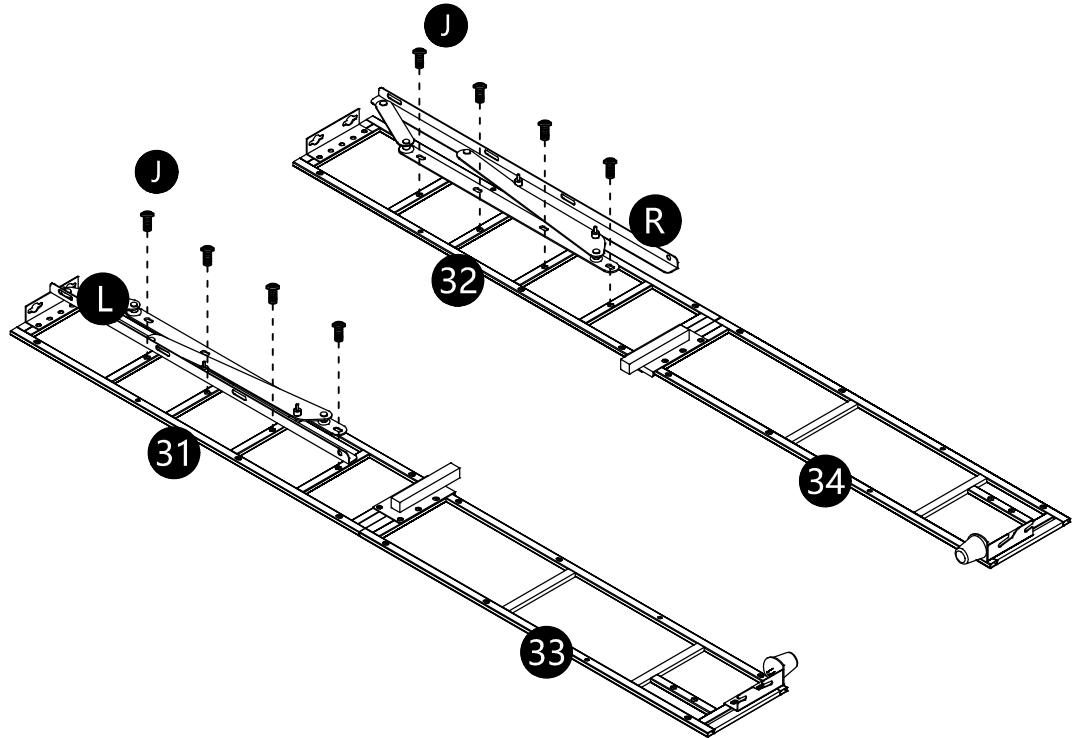

38

M8X15
KX4pcs

M8
XX1pc

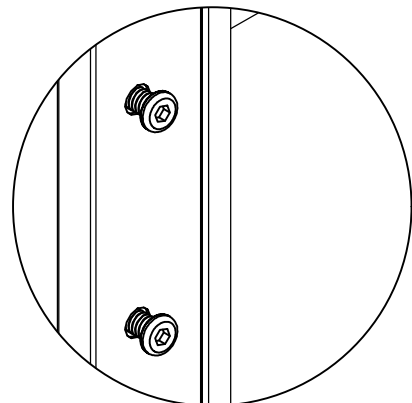
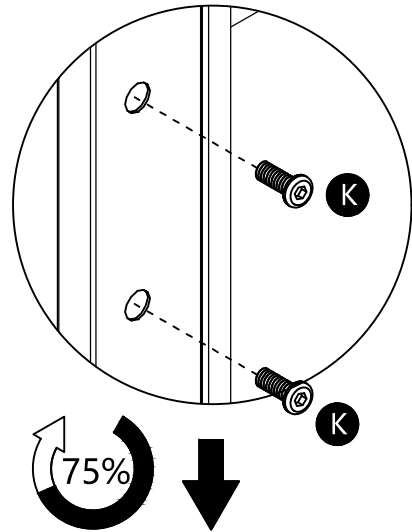
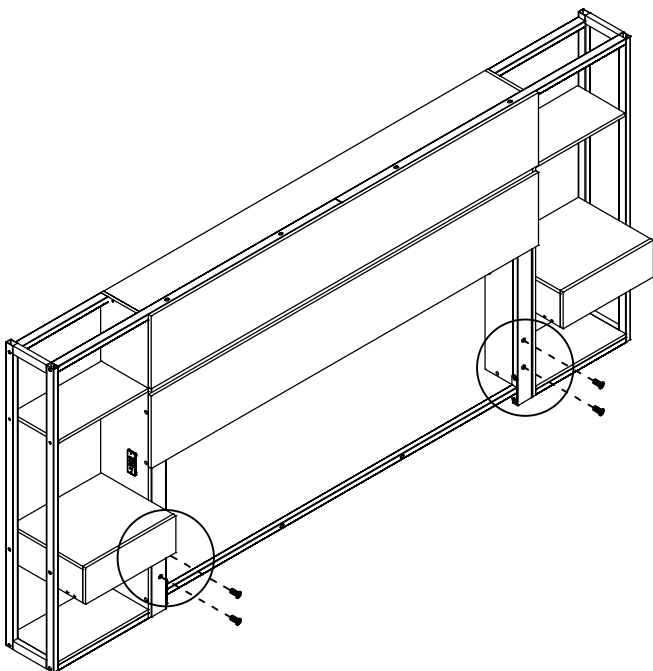

39

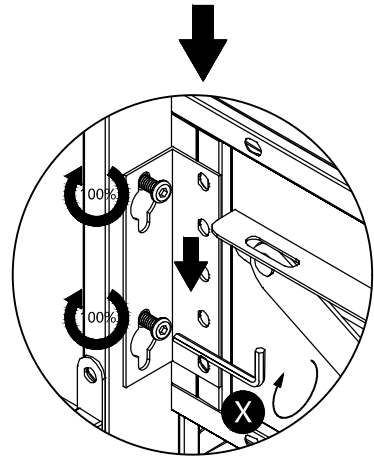
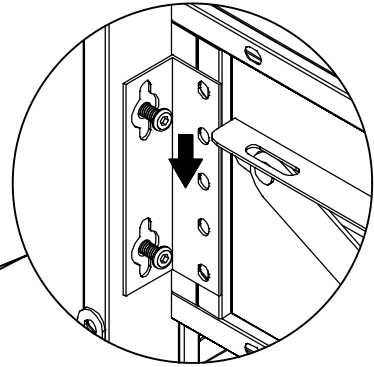
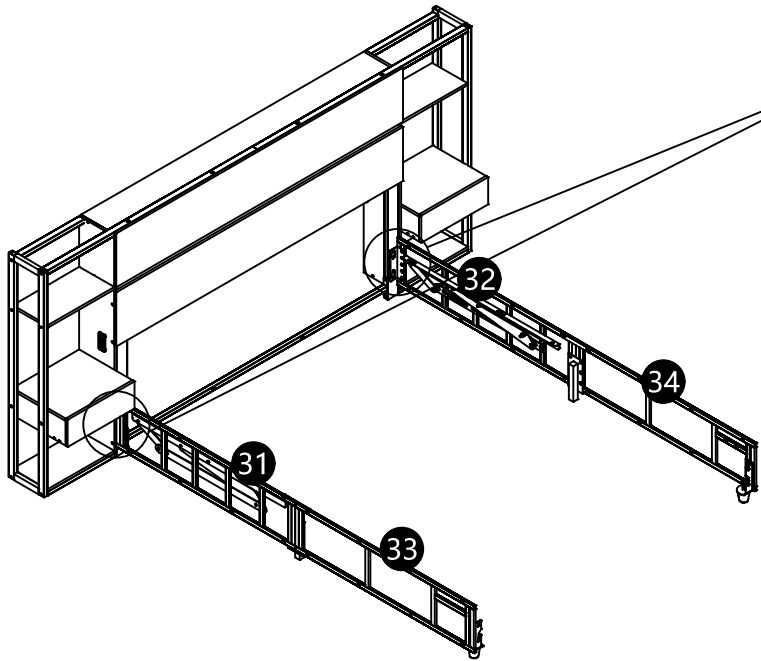

40

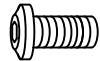

M8X13
JX4pcs

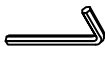

M8
XX1pc

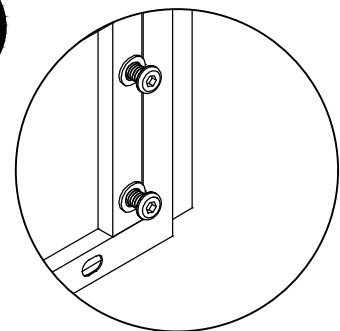
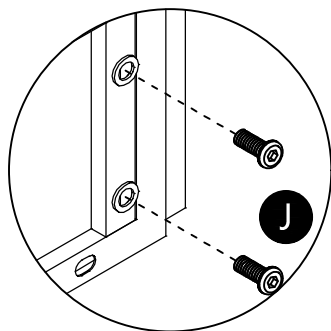
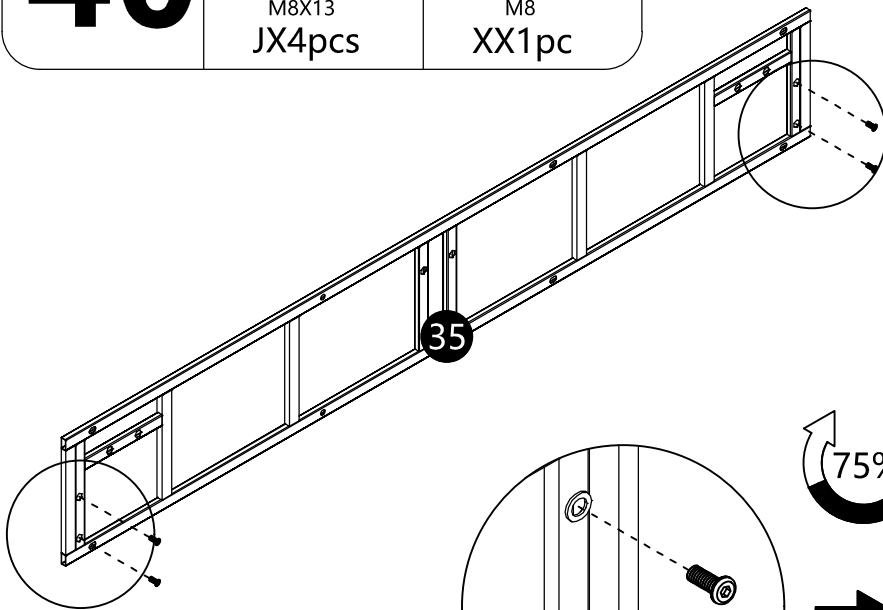

35/44

41

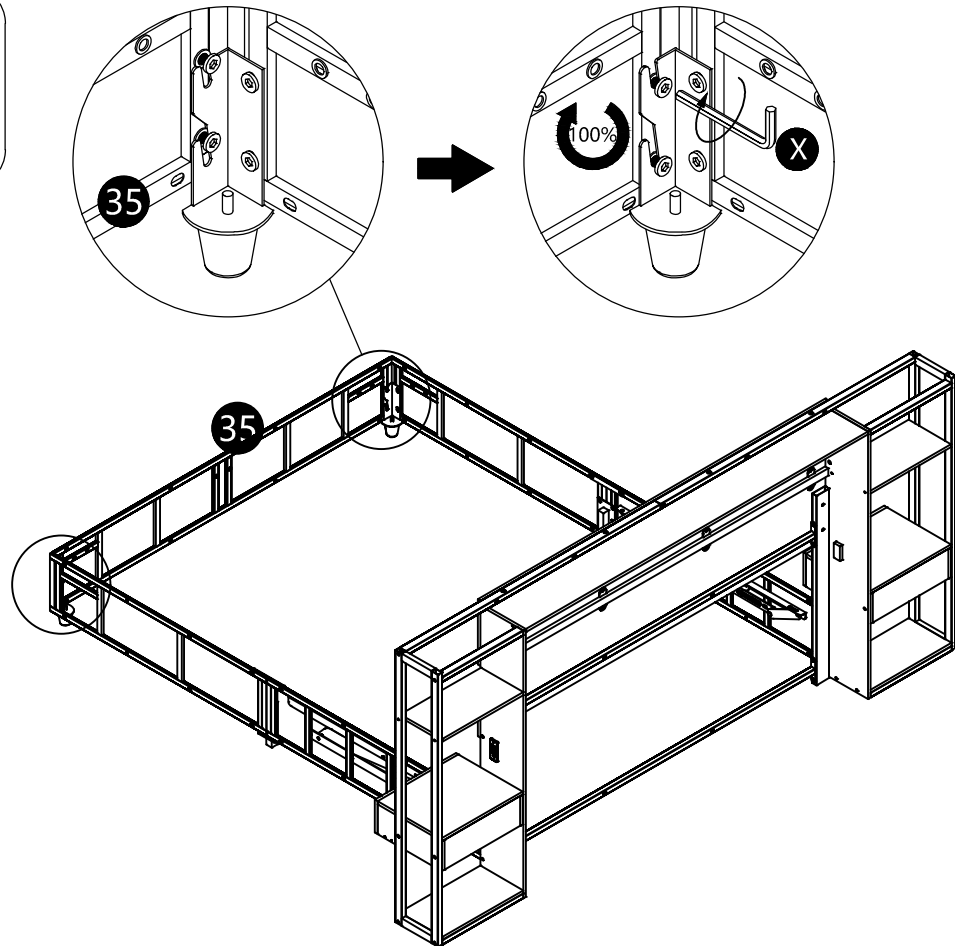

42



M6X20
CX16pcs

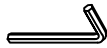

M6
WX1pc

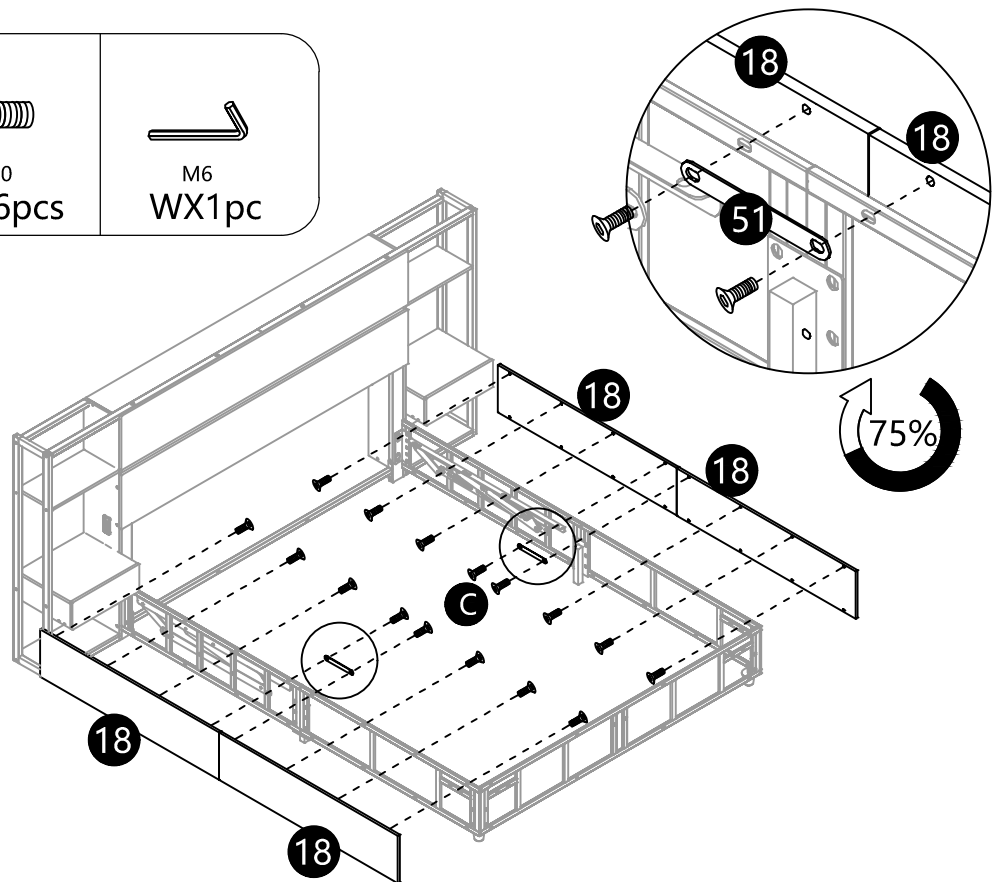

43

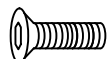

M6X20
CX16pcs



M6
WX1pc

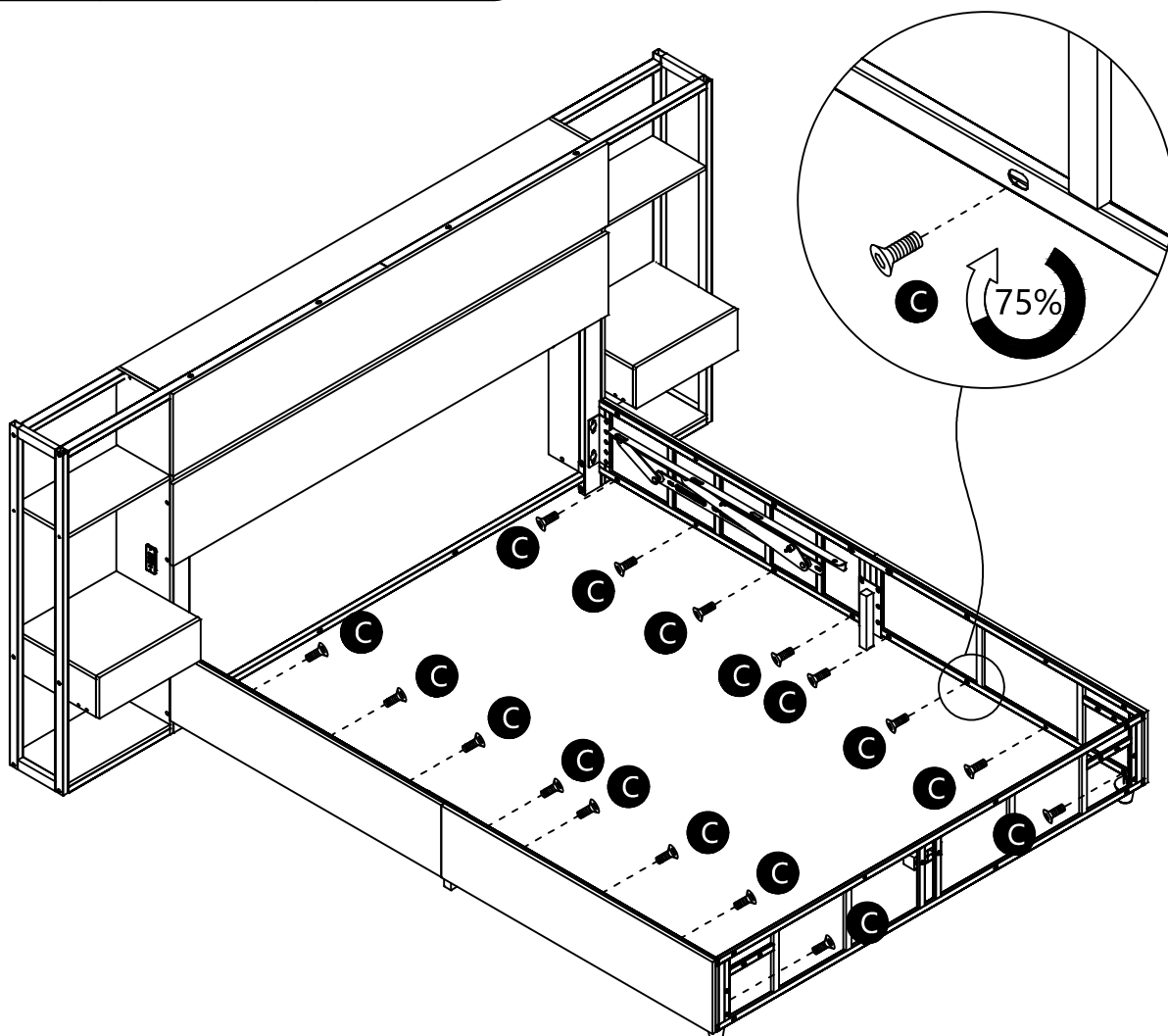

* After aligning all holes, fully tighten the screws from this step as well as steps 25 and 42

* Nach dem Ausrichten aller Löcher die Schrauben aus diesem Schritt sowie den Schritten 25 und 42 vollständig festziehen

* После выравнивания всех отверстий полностью затяните винты с этого этапа, а также с этапов 25 и 42

* Después de alinear todos los orificios, apriete completamente los tornillos de este paso, así como los pasos 25 y 42

* Dopo aver allineato tutti i fori, stringere completamente le viti da questo passaggio così come i passaggi 25 e 42

44

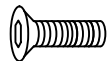

M6X20
CX8pcs



M6
WX1pc

- * Align the holes before fully locking the screws
- * Ausrichten Sie die Löcher, bevor Sie die Schrauben vollständig sperren
- * Alinez les trous avant de verrouiller complètement les vis
- * Alinea los agujeros antes de bloquear completamente los tornillos
- * Allinea i fori prima di bloccare completamente le viti

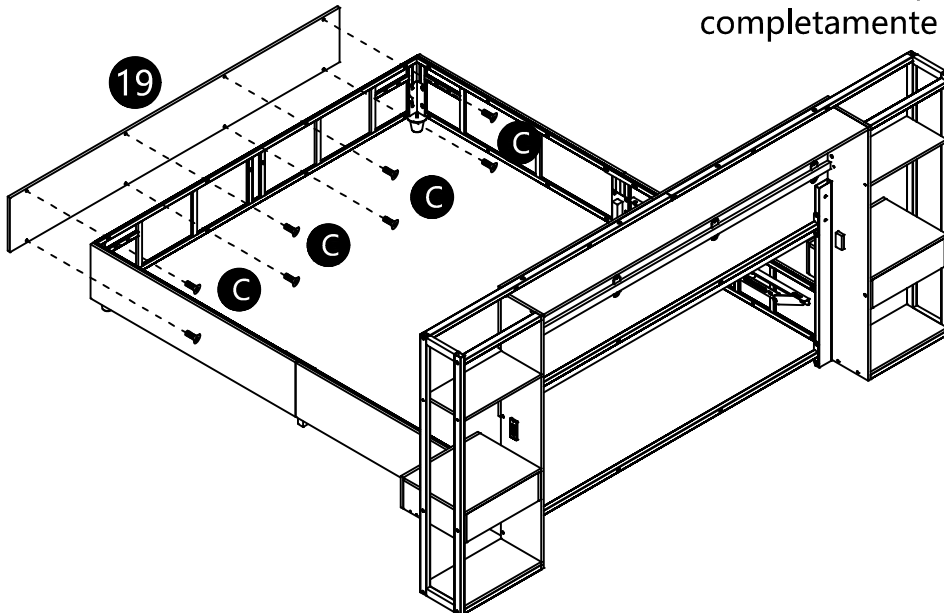

45



M8X13
JX4pcs



M8
XX1pc

- *For Step 45, please refer to the illustration for installation.
- *Pour l'étape 45, veuillez vous référer à l'illustration pour l'installation.
- *Für Schritt 45 beachten Sie bitte die Abbildung für die Montage.
- *Per il passo 45, fare riferimento all'illustrazione per l'installazione.
- *Para el paso 45, consulte la ilustración para la instalación.

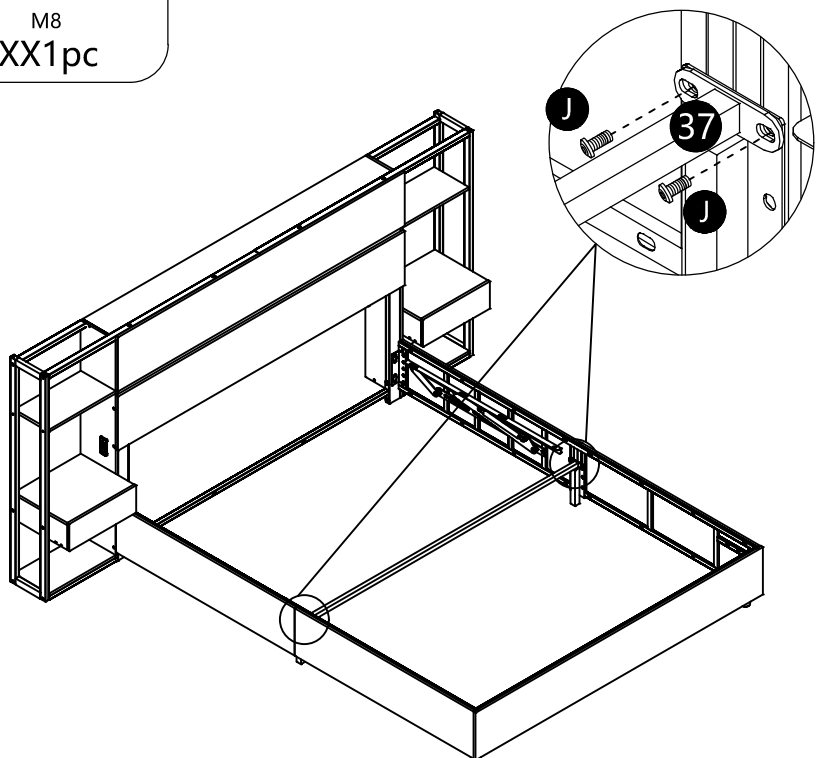

46

M8X13
JX8pcs

M8X35
NX2pcs

M8
XX1pc

A2X4pcs

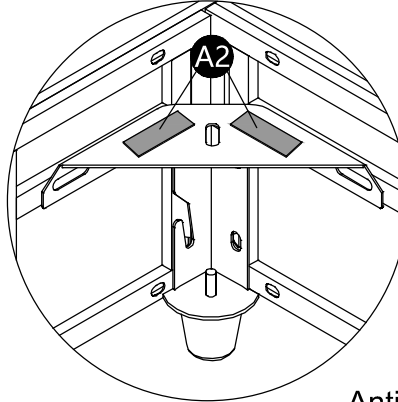
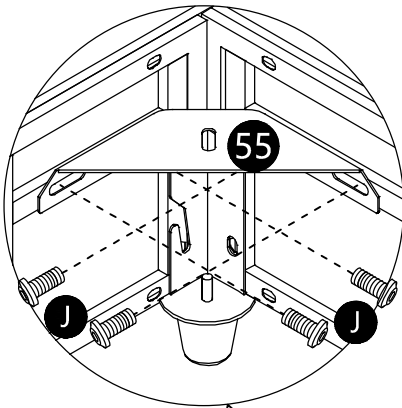

Anti stick
paper

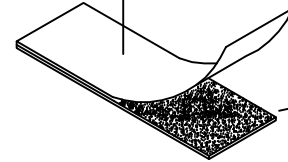

silent sticker

Silent sticker

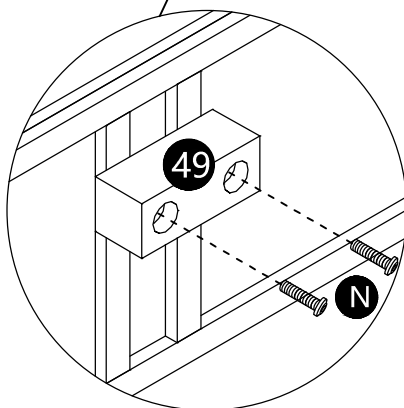
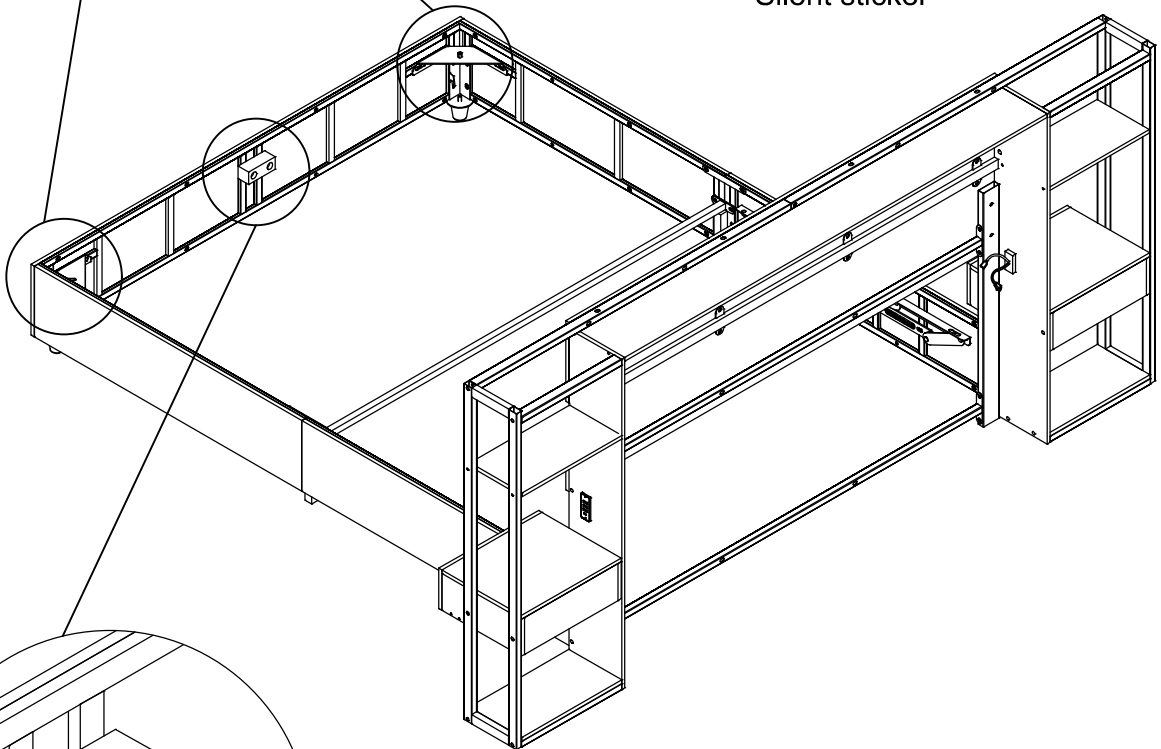

47

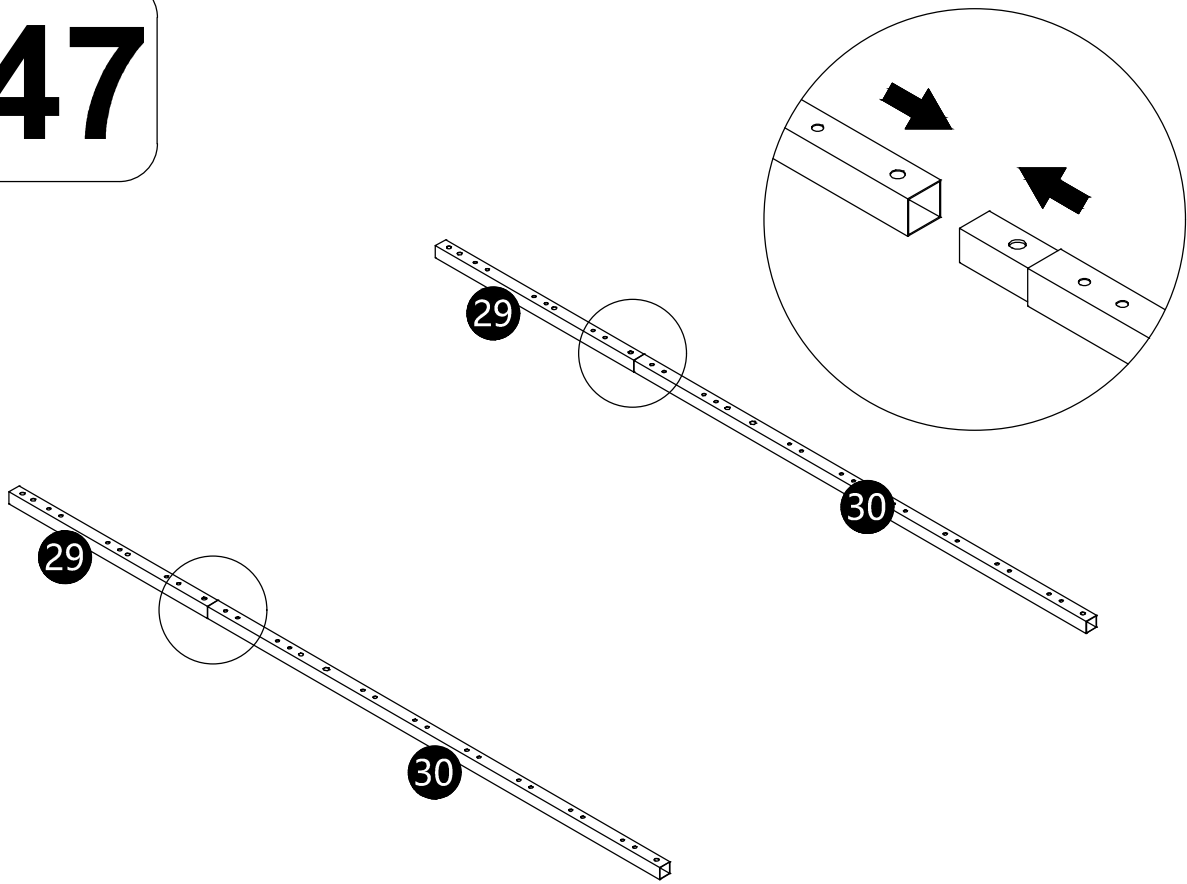

48



M8X13
JX8pcs



M8
XX1pc

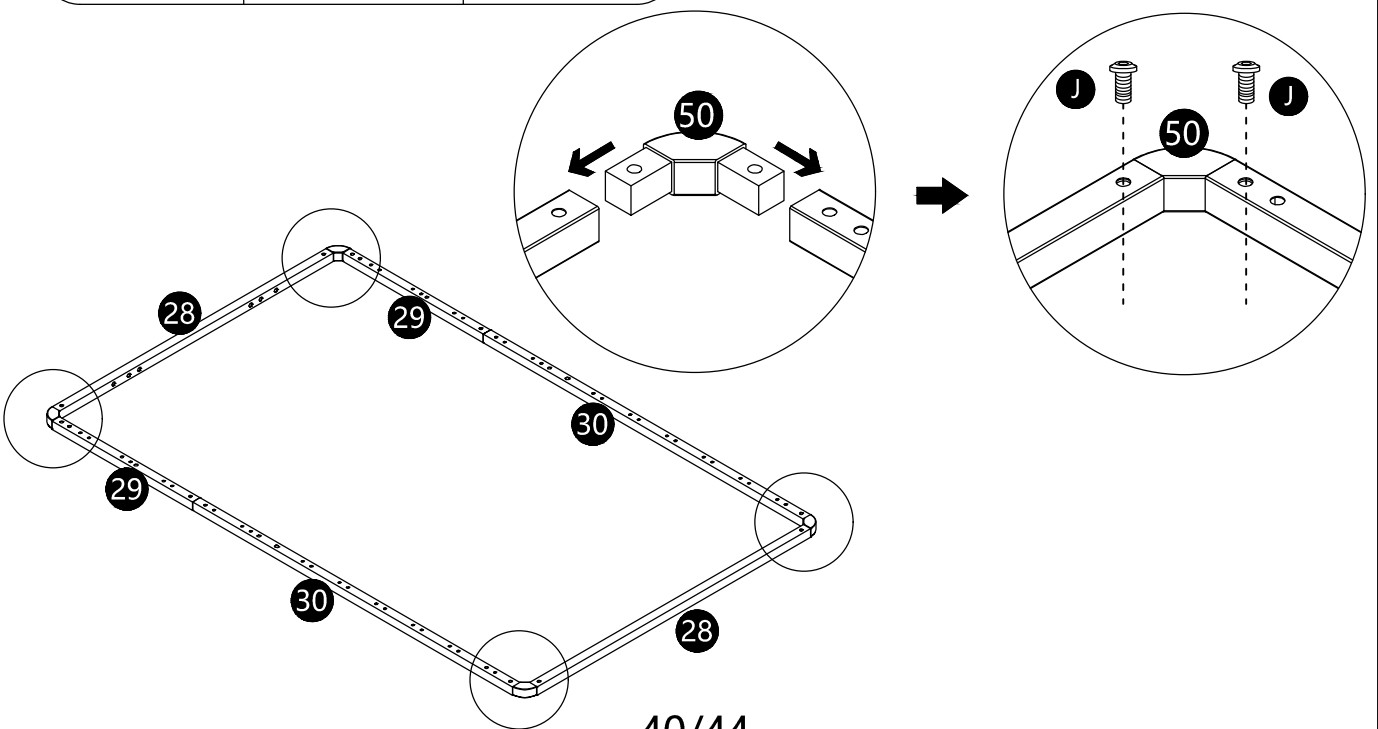

49

M8X15
KX2pcs

M8
SX1pc

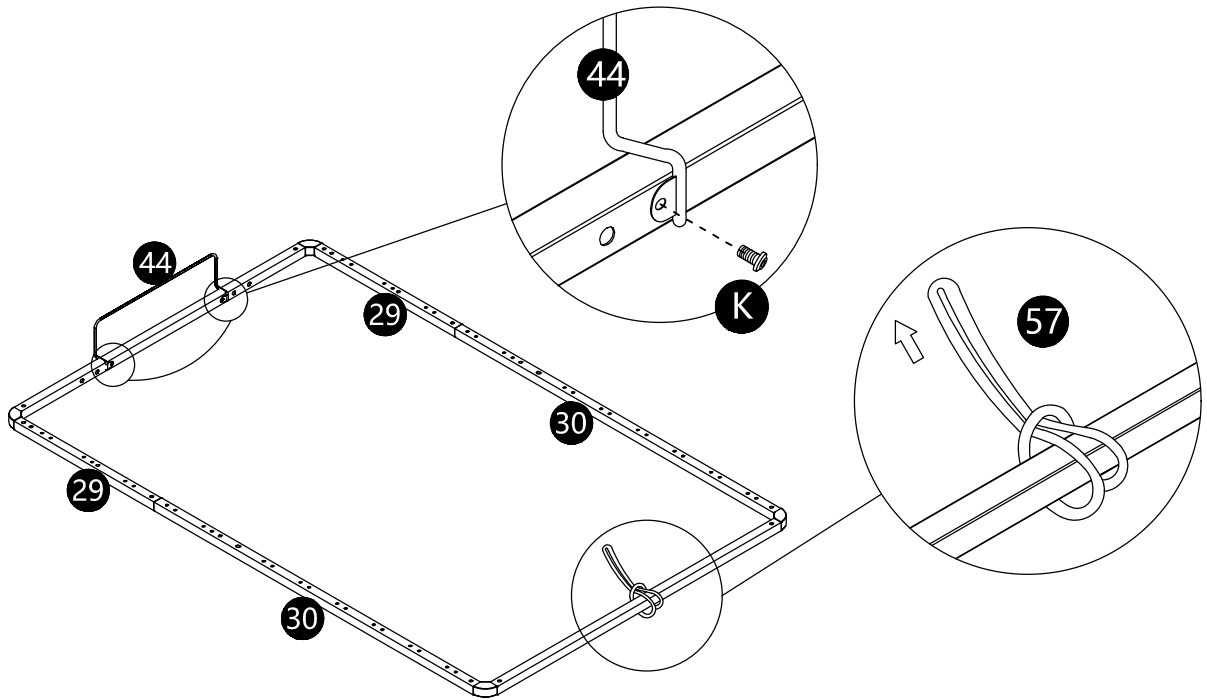

50

M8X45
OX2pcs

M8
XX1pc

M8
RX2pcs

ZX1pc

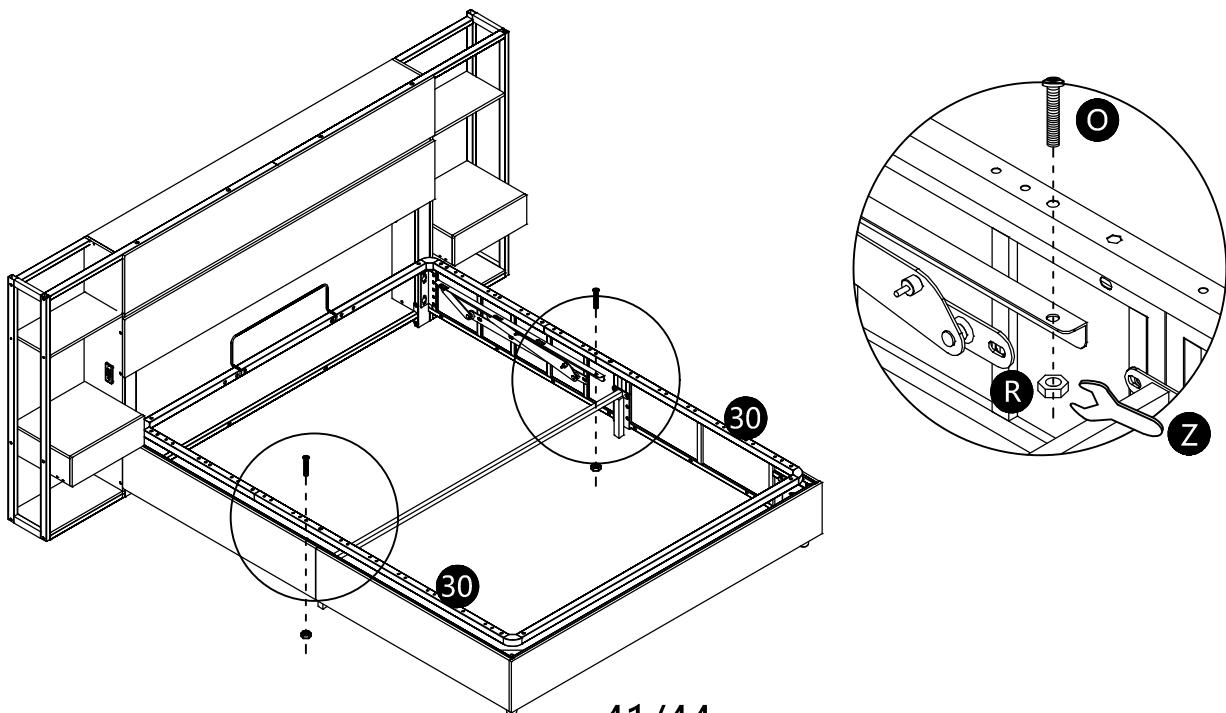

51



M8X45
OX6pcs



M8
XX1pc



M8
RX6pcs



ZX1pc

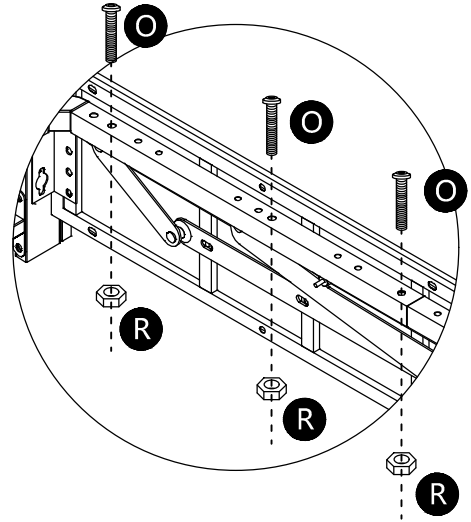
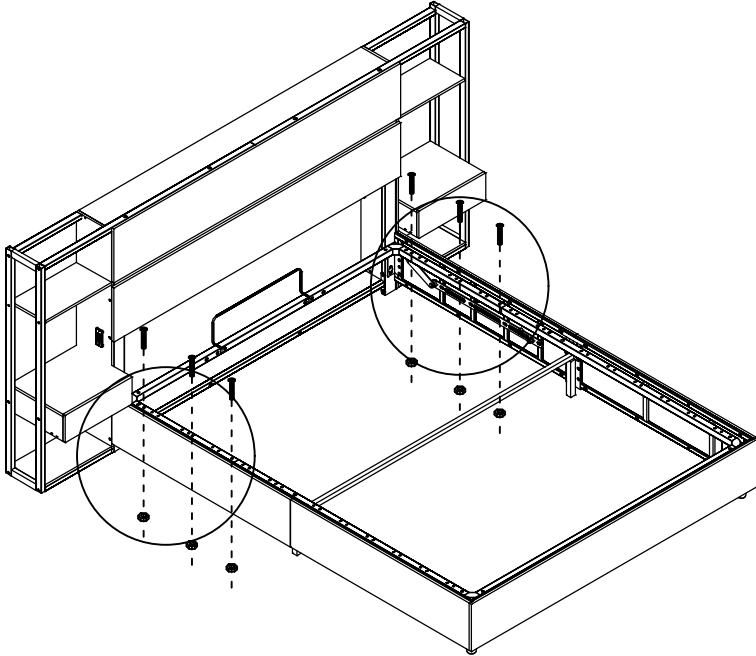

52

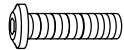

M8X35
NX8pcs



M8*Ø22
A1X8pcs



M8
XX1pc

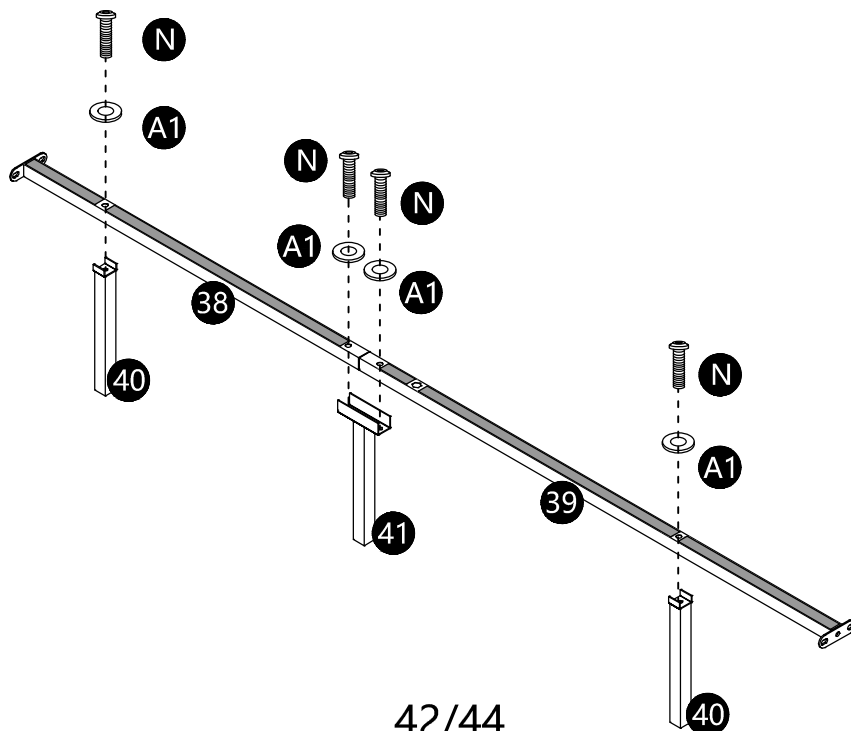

X2

53

M8X15
KX8pcs

M8
SX1pc

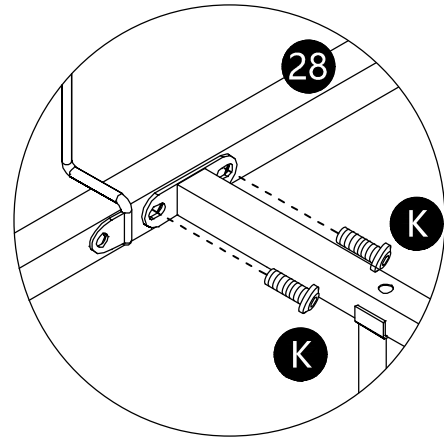
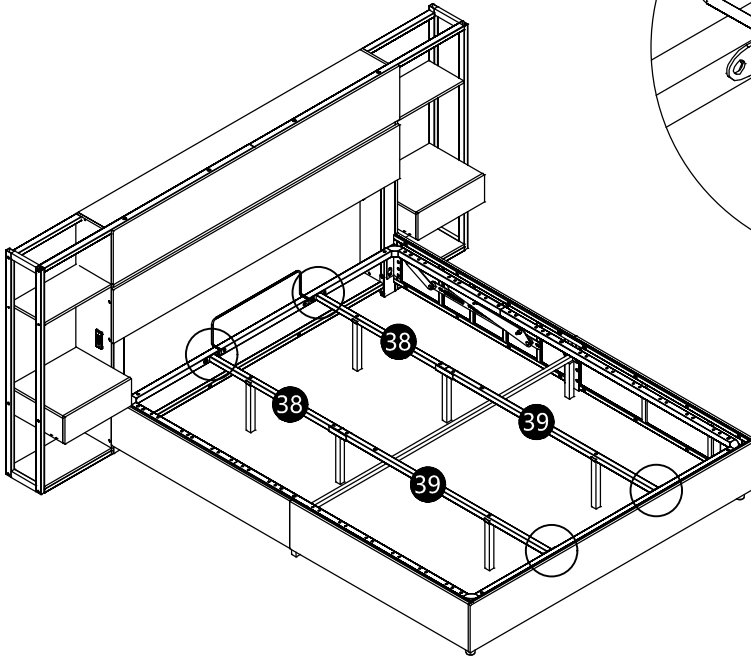

54

M8*30
MX2pcs

M8*35
NX2pcs

M8*Ø22
A1X2pcs

M8
XX1pc

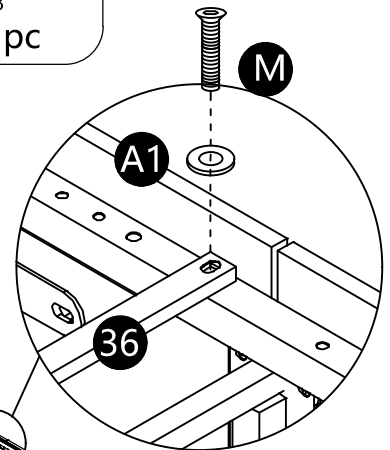
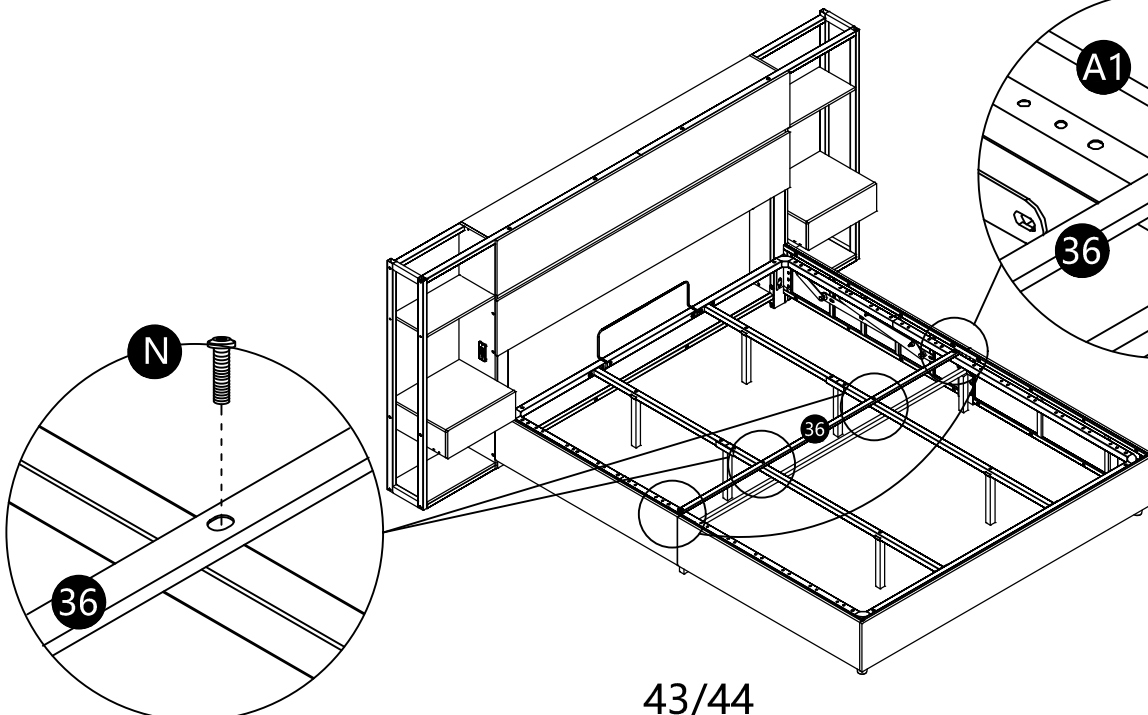

55

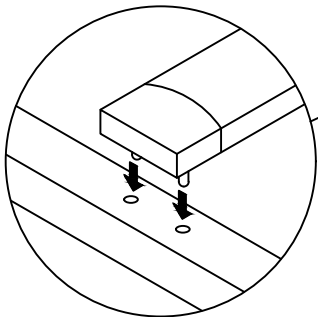
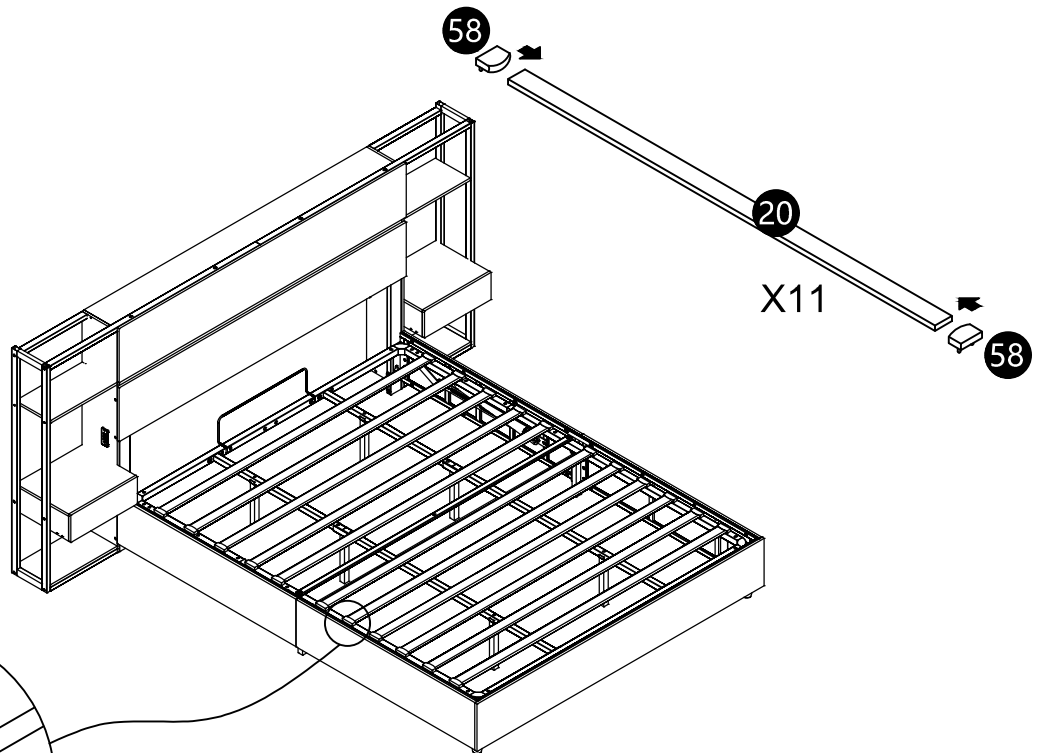

56



M8
RX4pcs



ZX1pc

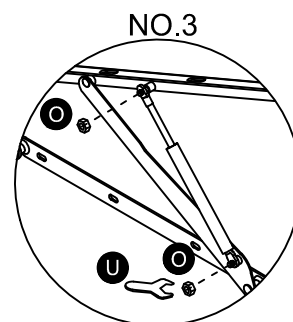
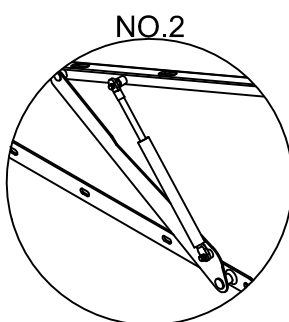
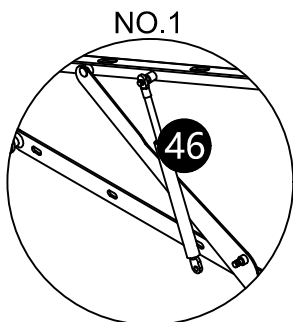
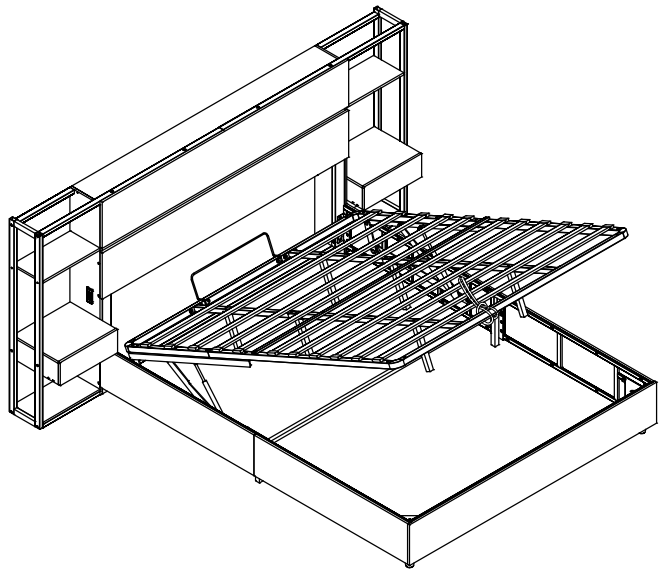

44/44

Shenzhen ZKT Technology Co., Ltd.

1/F, No. 101, Building B, No. 6, Tangwei Community Industrial Avenue,
Fuhai Street, Bao'an District, Shenzhen, China



Certificate of Compliance

Certificate Number: ZKT-250327L5653C

Certificate's Holder : Guangdong Zhangong Electric Technology Co., Ltd
701, Building 29, zhifuyuan Industrial Zone, Xingtan town,
Shunde District, Foshan City, Guangdong Province

Manufacturer : Guangdong Zhangong Electric Technology Co., Ltd
701, Building 29, zhifuyuan Industrial Zone, Xingtan town,
Shunde District, Foshan City, Guangdong Province

Trade Mark : /

Product : Mountable USB Hub/USB CHARGER

Model(s) : ZG-USB-12-B
ZG-USB-12, ZG-USB-12-C

Test Standard : EN 61558-2-16:2009+A1:2013 used in conjunction with
EN IEC 61558-1:2019

This Attestation of Compliance is issued on a voluntary basis for electrical equipment below the voltage limits of Low Voltage Directive 2014/35/EU. The essential requirements are fulfilled accordingly based on the technical specifications applicable at the time of issuance. See also notes overleaf. It is only valid in connection with the test report number: ZKT-250327L5653S.



This Certificate of Conformity is based on single evaluation of the submitted sample(s) of the above mentioned product. It does not imply an assessment of the whole product and relevant Directives to be observed.



Importeur	Decobus Handel GmbH		
Adresse	Innungsstraße 9, 21244 Buchholz, Deutschland		
Email/URL	https://www.decobusgroup.de		
Hersteller	Guangdong Zhangong Electrical Technology Co. LTD		
Adresse	701, Building 29, hifu Garden, Xingtang Town, Shunde District, Foshan City, Guangdong Province		
Email/URL	zkt@zkt-lab.com		
Partienumm	202505		
Hergestellt in	China		
<table border="1"><tr><td>EC</td><td>REP</td></tr></table>	EC	REP	Decobus Handel GmbH Innungsstraße 9, 21244 Buchholz, Deutschland https://www.decobusgroup.de
EC	REP		